

The first sixty years—A personal view

S. Ramaseshan

Professor Emeritus, Raman Research Institute, Bangalore 560 080, India

When the organizers persuaded me to give this talk on the First Sixty Years of the Department of Physics of the Indian Institute of Science, I had not realized the magnitude of the task I was undertaking. It could not just be a catalogue of the work done. Should it deal with history and science? Should it be anecdotal (and entertaining)? If so in what proportions? The path I chose was first to read all the annual reports, glance at the titles of the 1200 or so papers published, talk to a few scientists in and outside the Department. Then without too much preparation I gave the talk hoping that the best and the most interesting work will automatically come out, but quite aware of the potential risks. My personal preferences and prejudices could intrude; more importantly my ability to understand the physics behind some of the researches would become a limiting factor. I therefore apologize in advance to many who would be disappointed/annoyed, some for my not describing their work and others for my describing their work! It was when I was asked to produce a written version that the task became even more daunting. To convert what could be done with a wave of a hand, or an irreverent or irrelevant remark into cold print was something close to impossible. The fire and excitement of a verbal presentation before a live responsive audience tend to vanish. Perhaps the fault lies not only in my incompetence but also in those who asked me to write even after hearing the spoken version.

Introduction

The Pope Committee of the Indian Institute of Science recommended in 1921 the immediate establishment of a Physics Department at the Institute and it was established 'immediately' in 1933 with C. V. Raman as its head! It commenced work in July 1933. I joined it 10 years later in 1943. I feel greatly honoured that I have been chosen to speak to you on the First Sixty Years. I am eagerly looking forward to giving the sequel—the Second Sixty Years. I am honoured to see in the audience scientists like R. S. Krishnan, P. S. Narayanan, G. Suryan, R. Srinivasan and many others who have worked in the Department at some time or the other. I am also very happy to note the large turn out of young scientists, many of whom are members of the Department. My plan is therefore to concentrate on the earlier researches done in the Department as many of the younger members may not be too familiar with this period.

The Physics Department was housed in the main building of the Institute (Figure 1) which was completed in 1911 under the supervision of the first Director of the Institute, Morris Travers, who was Ramsay's collaborator in his discovery of the noble gases. It is said that the granite for the building came from Burma and the Chinese labour was imported by the Tatas who were contractors to the British army in China. With the establishment of the Physics Department, the library which was on the first floor on the east was extended to the west side which was previously a dance hall for faculty and guests!

C. V. Raman's room had his personal library and seminars were also held in it in the early days (Figure 2). The central workshop (Figure 3) was built in 1934–1935

which also had a large lecture hall. Some of the 1935 vintage seats are the more comfortable ones in the seminar hall of today. One may note the tiny saplings planted on the road by Raman, the lover of trees, which have now become one of the most magnificent avenues of the Institute. The workshop became operative even before the building was complete and was responsible for the construction of many scientific instruments used in the Department and also in the Institute. Even from the start the Department was a hive of activity. Instruments (spectroscopic, X-ray, electron diffraction magnets) were either constructed or bought. Figure 4 shows the spectroscopy laboratory with a battery of spectroscopes.

In an early annual report C. V. Raman writes:

Our knowledge of the ultimate structure of matter has advanced to such an extent that the fundamental and theoretical aspects of chemistry are today hardly distinguished from physics. . . . such practical subjects like engineering, aviation, transport, metallurgy, agriculture and medicine depend more and more on physics and advances in physics. . . . It is time physicists turn their attention to biology. . . . It is a misfortune that the creation of the Physics Department has synchronized with a period of financial stringency.

It is interesting that all the subjects mentioned have become a part of the Institute. Even in 1933 Raman had initiated researches on biological materials.

The early students and scientific problems

The first students were admitted during 1933–1934. The annual report states:

The satisfactory progress (of the Department) may be ascribed

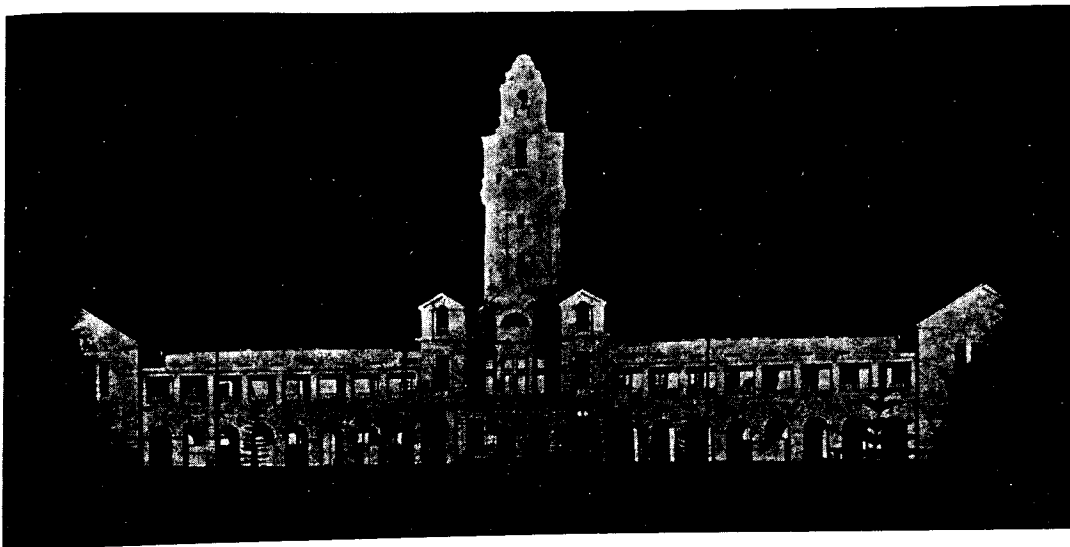

Figure 1. A photograph (taken in 1934) of the Central building of the Indian Institute of Science illuminated at night. The Physics Department was housed in the ground floor.

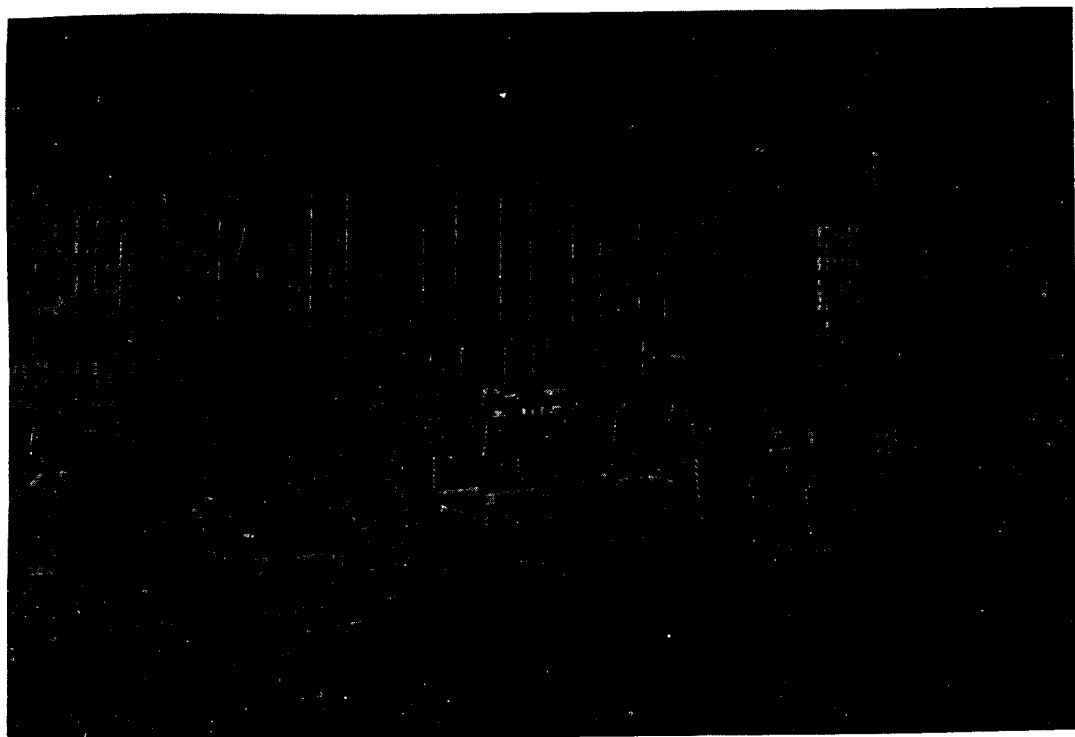

Figure 2. C. V. Raman's office and library where the Departmental seminars were also held in the early days.

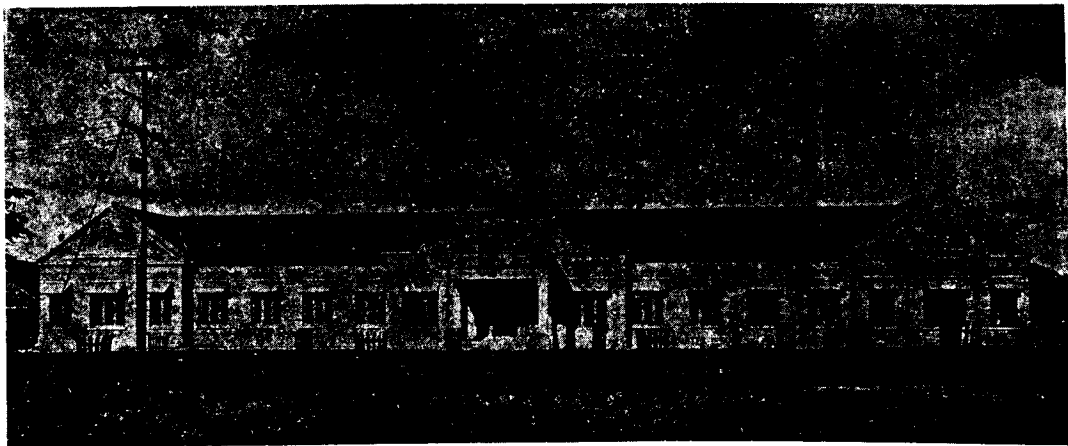

Figure 3. The Central Workshop (1935–1936) which also had the large lecture room where Raman, Born, Bhabha and many others lectured. Note the tiny saplings on either side of the road which have turned into a magnificent avenue.



Figure 4. The spectroscopy laboratory (1934–1935).

to the care which was exercised in the selection of students ... a gratifying proportion have shown energy and capacity ... many has shown distinctive originality and initiative in research ... students fresh to research have been encouraged to work independently and to publish their results under their own names.

Of the first 250 papers published less than 20 had joint authorship; probably a far cry from what happened later. The earliest students and the problems they were given were:

1. N. S. Nagendranath, (vibration spectra in crystals and molecules);
2. B. V. Raghavendra Rao, (Doppler effect in light scattering);
3. R. S. Krishnan, (Anomalous polarization in scattering—the Plotnikov effect);
4. D. S. Subbaramaiah, (depolarization of Tyndall scattering);
5. P. Pattabhiramayya, (dispersion of depolarization in light scattering);
6. G. Narasimhaiah, (optical anisotropy in molecules);
7. R. Ananthkrishnan, (Opalescence in binary gaseous mixtures);
8. S. Jagannathan, (Diffusion of light in liquid and solid surfaces);
9. C. S. Venkateswaran, (Raman effect in powders and crystal and coloured substances);
10. R. Venkatachala Iyengar, (The pianoforte problem).

C. V. Raman directed the researches of the students. There was no other staff member. He personally enjoyed working on the colours of bird feathers, the optical and mechanical properties of shells and on percussion instruments.

Early successes

(a) Within six months, gold was struck. Raman writes, 'In common with other members of the human race, many distinguished men of science have found the fascination of diamond too strong to resist'. The Raman effect of diamond was first studied in 1930 by C. Ramaswamy (Raman's brother) who recorded for the first time the 1332 cm^{-1} line. Later Robertson, Bhagavantham and many others worked on it. Earlier attempts to calculate this frequency gave any number from 990 cm^{-1} to 3330 cm^{-1} . The diamond is a giant molecule in which every carbon atom is bonded tetrahedrally to its neighbours (Figure 5a). The Bragg structure showed that diamond consisted of two face-centred cubic lattices displaced along the cube diagonal. Nagendra Nath showed that the 1332 cm^{-1} is the frequency of these two lattices moving relative to each other, each being considered as rigid (Figure 5b). The theoretical calculation was based on the known strength of the C-C bond. Max Born considered this work as pioneering and one of the important advances made in crystal physics. He also appreciated the simplicity of the entire approach. Nagendra Nath also calculated the elastic constants of diamond using the dynamical theory and this too was considered as breaking new ground in solid state theory.

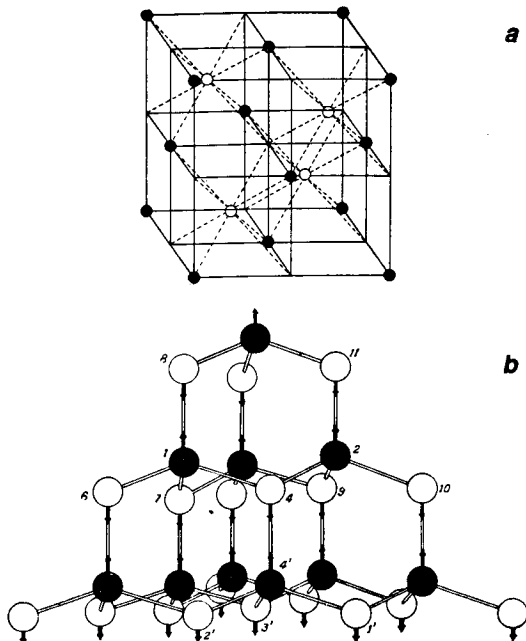

Figure 5. a, The structure of diamond. b, Lattice oscillations of diamond.

(b) Brillouin scattering. The Smoluchowski-Einstein theory of light scattering by molecular structures ignored fluctuations of density due to the presence of sound waves. Brillouin first proposed that a medium scattering radiation can be treated as a continuum filled with moving high frequency sound waves of various wavelengths. These Bragg reflect the light, the reflections also exhibiting Doppler shifts. In 1922 Raman had suggested that the Fabry-Perot etalon along with a spectroscope should be used to detect the two Doppler shifted components in molecular scattering. As soon as he came to Bangalore he asked young B. V. Raghavendra Rao to try the experiment. This student obviously had an exceptional experimental skill and was able to observe the two Brillouin components in liquids in his first attempt. Even in the early papers they discussed the mystery of the appearance of the central component. They studied the velocities of these hyper-sonic waves, their dispersion with wavelengths and compared them with the data for ultrasonic waves, and their temperature variations. Since mercury lines showed a hyperfine structure which interfered with the observations in the Fabry-Perot, a zinc-mercury arc was developed and some of the most beautiful pictures of Brillouin scattering were recorded (C. S. Venkateswaran,

K. Sunanda Bai). Perhaps the most exciting result was obtained when Raman and Raghavendra Rao by polarization studies demonstrated that viscous liquids behave like amorphous solids at these high frequencies since they sustain transverse waves in addition to the usual longitudinal waves (Figure 7).

(c) Out of these studies at high frequencies came the pretty idea that in calculating the intensity of scattered light one had to use the adiabatic piezooptical constants and not the isothermal ones (shades of Newton/Laplace in the case of sound velocities). This prompted the accurate measurement of the adiabatic piezooptical constants for a series of liquids and the paper by (Sir) Venkata Raman and Venkata Raman in the Royal Society is considered to be a classic. When these values were introduced, the calculated values of the scattered intensities agreed very closely with the experimentally determined ones (K. Sunanda Bai).

(d) *Colloid optics and the reciprocity theorem.* Raman and his collaborators in their work on the scattering of light in transparent substances like optical glasses, binary liquid mixtures, protein solution and even rubber dissolved in organic solvents discovered scattering due to thermal fluctuation, compositional variations and clustering. The molecular physicist was interested in the molecular structure, anisotropy and aggregation whereas the colloid chemist or biologist was interested in the number, the size, and the structure of the particles dispersed in the medium. It was an anathema to Raman and his school to set rigid lines of demarcation between colloids, turbid media, and molecular liquids. That was the reason why an intensive study of the Tyndall effect and colloid scattering was taken up to see whether a unification of colloid and molecular optics could be achieved (Figure 6a). R. S. Krishnan did this by establishing the reciprocity relationship in colloid optics (which is really an extension to optics of the principle proposed by Helmholtz and Rayleigh in the case of mechanics). Irrespective of the nature, size, shape of the particles it was demonstrated that $H_v = V_h$. Figure 6a shows the states of polarization when the incident beam passes through a double image (DI) prism and is then scattered. The scattered tracks are viewed with a second DI prism. Figure 6b indicates the states of polarization of the tracks for different sized scattering particles. In this process a new effect, named by Gans as the *Krishnan effect* was discovered. If the incident light beam is polarized horizontally and light scattered transversely and if it is partially polarized then $V_h < H_h$, i.e. the horizontal vibration is more intense than the vertical vibration. The importance of this effect to light scattering was discussed by C. V. Raman, Hans Meuller and Jean Perrin and others. A much better and more quantitative technique was developed (T. A. S. Balakrishnan) where a Babinet compensator was used to

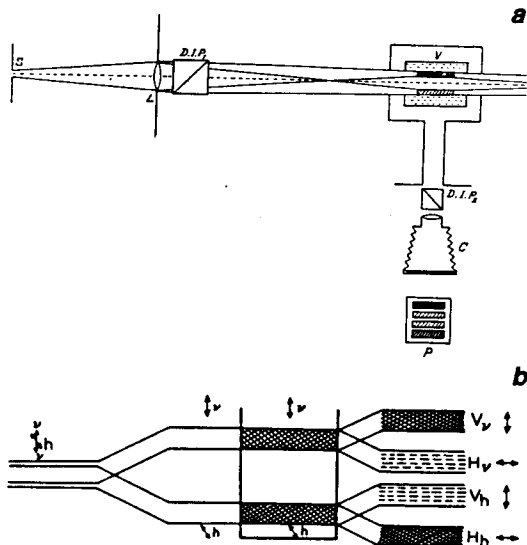

Very small, spherical and isotropic,

$$V_v \neq 0, H_v = V_h = H_h = 0.$$

Not small but are spherical and isotropic,

$$V_v \neq 0, H_v = V_h = 0, H_h \neq 0.$$

Very small but are not spherical and isotropic,

$$V_v \neq 0, H_v = V_h = H_h \neq 0.$$

Neither small nor spherical and isotropic,

$$V_v \neq 0, H_v = V_h \neq 0, H_h = 0.$$

Figure 6. a. Arrangements for studying colloid scattering. b. Demonstration of reciprocity principle in light scattering.

view the tracks instead of a double image prism. Partial polarization as low as 2% to 3% could be detected. The Babinet fringes could be photographed, and so the studies could be extended to the UV. Elliptic polarization too could be detected and measured so that colloids with the smallest particles and even pure liquids could be studied by this technique.

(e) *Raman-Nath theory.* Raman and Nath explained the phenomenon occurring when a parallel beam of light is diffracted by ultrasonic waves travelling in a liquid. The original observations were made by Debye and Sears in the USA and Lucas and Biquard in France who found that the diffraction pattern showed a surprisingly large number of diffraction orders with an irregular distribution of intensity among them (Figure 8a). These features could not be explained by the theories put

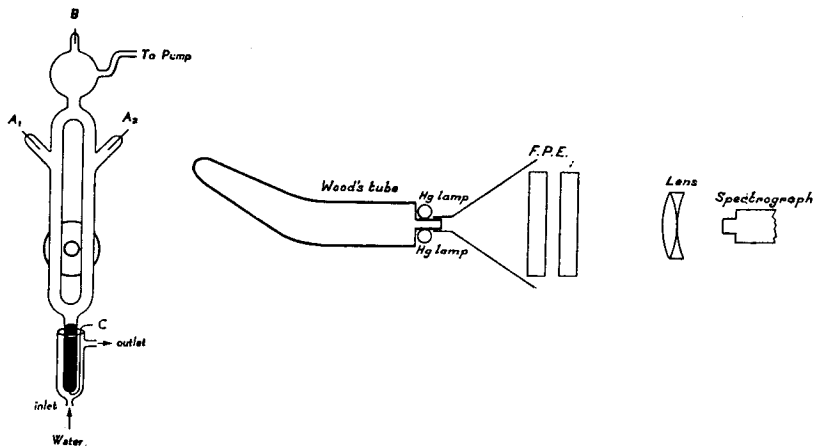

Figure 7 a. Experimental arrangement for studying Brillouin scattering in liquids.



Figure 7 b. The Brillouin pattern of direct and scattered light as observed by a Fabry-Perot etalon showing the presence of two Doppler components and the absence of any red shift of the central components.

forward by Debye, Brillouin and others. Bär of Switzerland also found that *the intensities of the diffraction spectra depended not only on the wavelength of light but also on the intensity of the supersonic waves, the thickness of the cell and the angle between the light beam and the sound wave.* To explain all this Raman and Nath introduced the concept that the incident plane wave front becomes 'corrugated', i.e. strongly phase-modulated. They also introduced the associated mathematical tool—a set of first order differential-difference equations. And as Bär remarked *to and behold the Raman-Nath theory explained all the observations and made a few predictions which were also experimentally verified.* A rather interesting part of this story is that the actual formulae for amplitudes involve Bessel functions in which the discoverer of the phenomenon Debye was an acknowledged expert. It is said that it was after a review seminar by a research scholar on ultrasonic diffraction Raman went up to the board and in half an hour formulated the physical basis of the new theory which received its elegant mathematical form in the hands of Nagendra Nath. The ideas put into the Raman-Nath theory found application in many other fields, e.g.

the multiple beam dynamical theory of electron diffraction. Further the idea of an equation which is first order in the direction of propagation and second order in the transverse direction (the parabolic equation approximation) which plays a significant role in wave propagation in random media is contained in the Raman-Nath paper.

Classical optics

The Indian contributions to classical optics both in experiment and theory during this period were much ahead of the times. Now that classical optics has made a comeback in the West, some of the phenomena and theories discovered in India long long ago are being consistently rediscovered (independently, of course). One is reminded of Will Durant's description of our eighth century philosopher Shankaracharya as the preplagiarist of the eighteenth century Emmanuel Kant. Many of these optical researches from India have been embodied in the classic monograph by C. V. Raman entitled *Lectures in Physical Optics*—lectures which were delivered in the early forties but published only in 1959 by the Indian Academy of Sciences. I shall select a few important contributions:

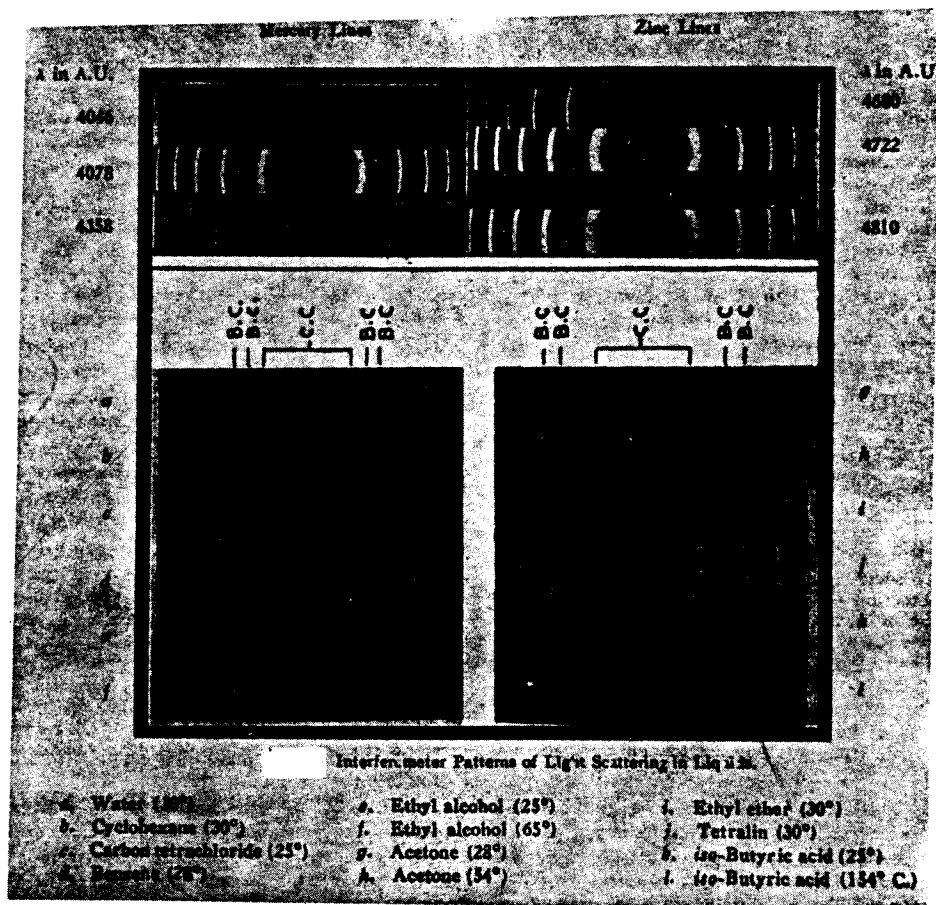

Figure 7c. The difference in the fine structure spectrum between mercury arc and the 'Zn' arc which was developed for Brillouin scattering studies and interference patterns in light scattering of liquid.

(a) One of the most beautiful phenomena seen in nature, especially in minerals and which could be reproduced in the laboratory is the *Liesegang precipitate* (Figure 9 a). The similarity between wave patterns and these periodic precipitates have long been noticed and the physical basis of the latter was conjectured to be the interactions of diffusion waves. Establishing this was by no means easy because while the density of precipitates must necessarily be positive, the disturbance in a wave train can either be positive or negative. Establishing this was one of the achievements of the Department. By using very novel experimental techniques, beautiful microphotographs were taken (K. Subba Ramaiah) of precipitates formed over extremely tiny region when two ionic solutions intermingled by diffusion in a gelatine medium. These showed not only direct interference and

diffraction effects in the precipitates but also many other recondite phenomena including the effects of 180° phase change across boundaries and of wave and group velocities which demonstrated unequivocally that phase relationships between the waves must have caused the precipitates (Figure 9 b).

(b) Soap bubbles have had a strange way of attracting the attention of children and scientists because of the colours they exhibit. But precise experiments using them were difficult. By very elegant techniques *soap bubbles were kept spherical and of uniform thickness* and Haidinger's rings were observed in these curved surfaces by reflection and transmission for the first time (Raman and Rajagopalan) (Figure 10). The crucial and difficult problem of localization of Haidinger's rings on curved plates was discussed for the first time, a problem which later

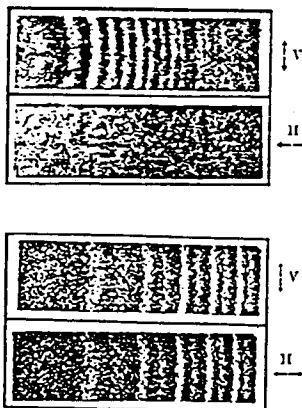

Figure 7d. In a normal liquid (toluene): Only vertically polarized component is present. In viscous liquids (phenol): Both vertical and horizontal components are present indicating the presence of longitudinal and transverse sound waves.

became of importance after Tolansky's interferometric studies.

(c) The phenomena of internal and external conical refraction predicted by Hamilton and observed by Lloyd in aragonite are considered triumphs of the application of wave theory of light to crystal optics. These were difficult to observe because of the very small angles involved in aragonite ($1^{\circ} 52'$ and $1^{\circ} 42'$). In a naphthalene crystal (grown by the Bridgman method for Raman effect studies) the conical refraction was shown to be enormous, almost seven times larger ($13^{\circ} 44'$ and $13^{\circ} 51'$) so that it was very easy to observe and what is more an extremely interesting phenomenon was demonstrated. A luminous object when observed through the singular direction forms a *bright, well defined erect image of unit magnification with a most unexpected property—the image is continuous*, i.e. (unlike in a lens where the image can be observed only at a single focal plane) this image may be observed anywhere along the line and strangely with very little decrease in intensity with distance as though the image and the energy travel in a parallel fashion. This peculiar phenomenon was shown to be due to the image formed by a *dimpled wavefront* generated by the double refracting crystal. This wave shape has found application in the field of

explosive forming of metals and gravitational lensing! (d) One of the major achievements of the optical physicists of India is photographing the exquisite Fresnel patterns of obstacles and apertures with a wide range of geometries. The beauty of the photographs taken by Y. V. Kathavate of triangles, squares, ellipses and other odd shaped figures (most of them for the first time) has to be seen to be believed (Figure 11).

The purist knows that the rigorous electromagnetic treatment or the simpler Kirchoff formulation should give, after much effort, the Fresnel diffraction pattern of any object or aperture—although this has not been done. In addition, such laborious procedures would afford no insight at all into the relationship between the form of the obstacle (or aperture) and the character of the diffraction pattern. The Bangalore group influenced greatly by the concept of Young's edge waves (made rigorous by Maggi and Rubinowicz) postulated radiating corners and poles and geometrically derived simple and elegant rules by which the Fresnel pattern of *any complex shape* can be directly plotted on a sheet of paper. The ease with which Kathavate could deduce the fine tracery of the Fresnel patterns by following these extremely simple rules is truly astounding. G. N. Ramachandran wrote a paper giving some theoretical justifications to these

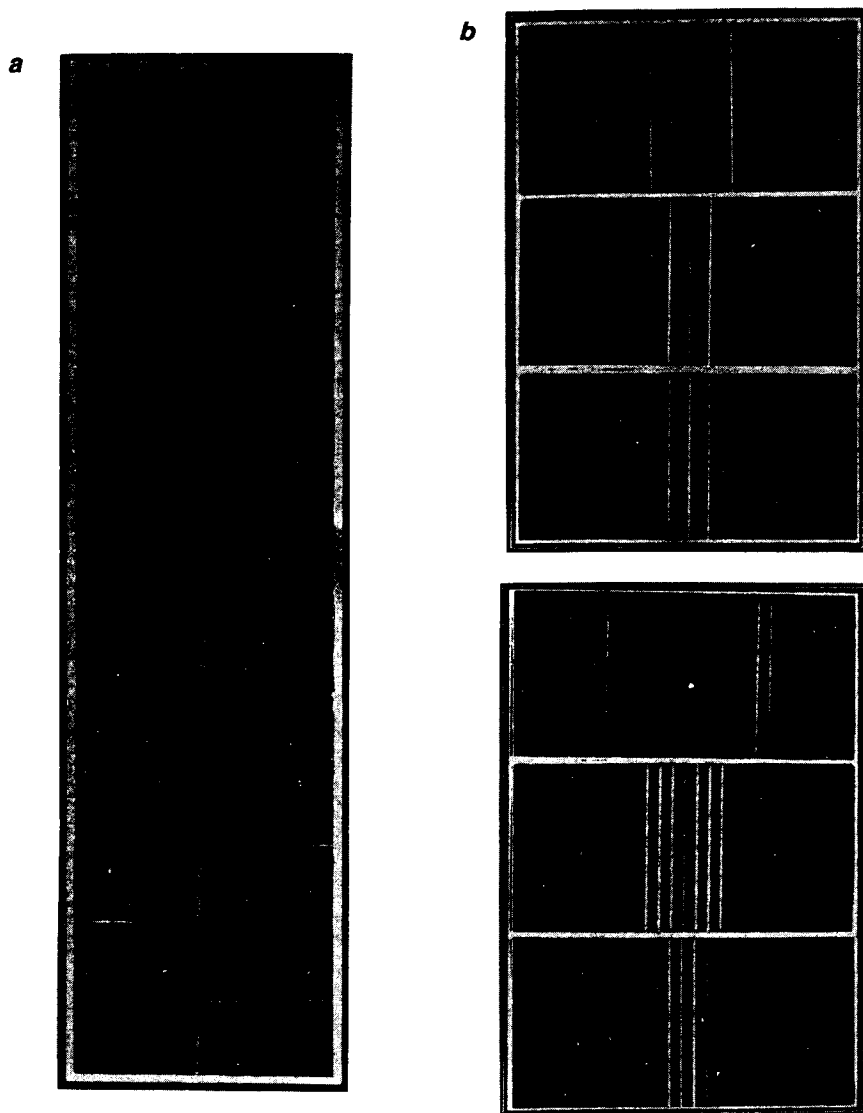

Figure 8. Raman-Nath theory—verification. *a*, Diffraction spectra: small angles between the incident light beam and the sound wavefront. *b*, Changes in diffraction pattern with increase in amplitude and the wandering of the intensity amongst various orders.

rules. Twenty years later virtually an identical theory was evolved (independently) by Keller in the USA and it goes by the name of the *geometric theory of diffraction*. (e) The Fresnel diffraction patterns of transparent three dimensional objects like spheres and spheroids which had never been seen before were observed and photographed for the first time. The patterns display

most peculiar effects—concentration of intensity along the axis, the peripheries, the foci and evolutes. There are hundreds of superposed interference fringes; caused by the edge radiations and caustics. Birefringent spheres showed two caustics, each having its own set of interference bands. To explain many of these beautiful, yet complex effects one had to resort to both ray and wave optics.

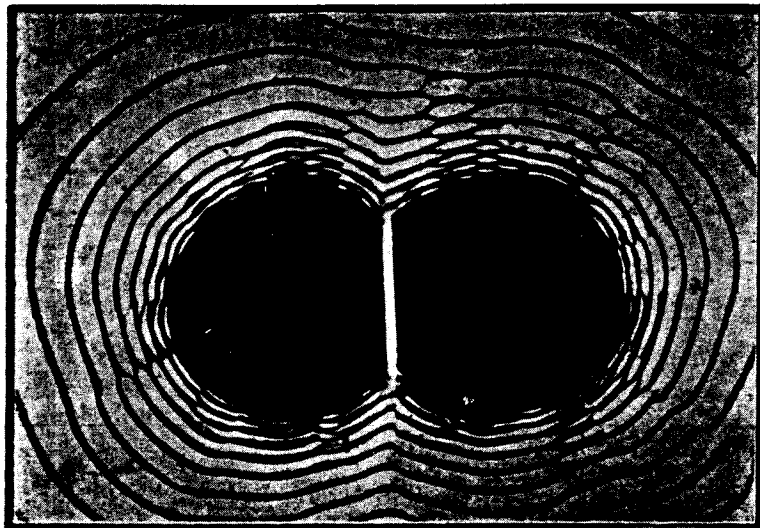

Figure 9a.

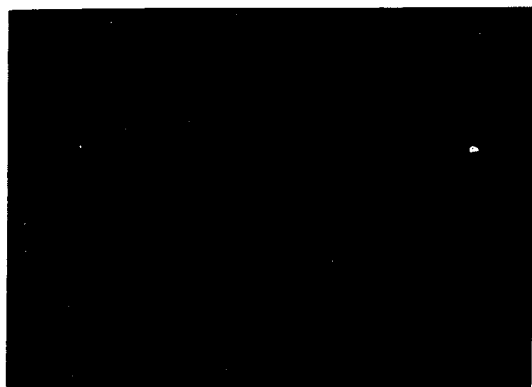

Figure 9. a. Liesegang periodic precipitates with two sources. b. Two waves meeting at small angle; the staggering of the precipitates across the boundary is due to the phase change of 180° in waves across the boundary. Note also the effect of wave velocity and group velocity.

(f) The *speckle* phenomenon which is so familiar to many after the lasers came in was discovered by Raman, Exener, de Haas and others before 1920 (Figure 12). Much progress in the quantitative understanding of this phenomenon was made at Bangalore in the forties. The Fraunhofer pattern of a (spherical) particle exhibits itself as a halo with several maxima and minima ($I = J_1^2(x)/x^2$) and n particles randomly distributed on a glass plate would give the same pattern but with n times the intensity *on the average*. Because the number of dif-

fracting particles on the screen has increased the n waves scattered by these n particles interfere and these interference effects get superposed on the diffraction pattern. If the particles are (assumed) of equal sizes, the amplitudes of the scattered waves will be equal but their phases will depend on the distances of the source to the particle and the particle to the point of observation. Since these particles are randomly distributed, the phases at different points of these n waves reaching the screen will add up randomly to interfere. The intensity dis-

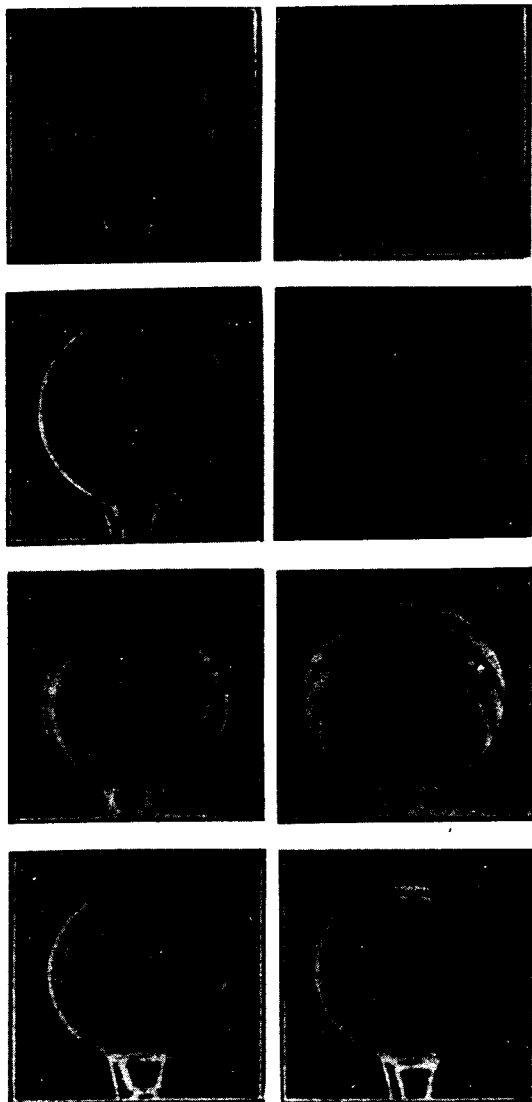

Figure 10. Interference figures in soap bubbles.

tribution of the maxima will therefore follow the *Rayleigh law* (derived from the random walk problem). Because of these interference effects the maxima of the Fraunhofer halo will have on them superposed spots which exhibit violent fluctuations in intensity. The halo will appear mottled. Many of the quantitative deductions of this *speckle phenomenon* were verified (G. N. Ramachandran) in haloes formed by lycopodium powder spread on glass plates. It was also at Bangalore that *dynamic speckles*

were first discovered (Raman) when observing the diffraction halo due to colloids. The speckles formed in the halo move because of the regular flow of the medium and they also scintillate like stars due to the random Brownian motion of the colloidal particles. This *speckle phenomenon* due to random addition of phrases shows itself in many other physical problems as we shall see.

G. N. Ramachandran

G. N. Ramachandran (GNR) who was one of the outstanding scientists the Department produced first joined the Electrical Engineering Department (EE) of IISc. Since he longed to work with Raman he came every evening to plead with Raman who too was keen on taking him as a student. Not to offend the acerbic head the Electrical Engineering Department Raman met him and requested for the transfer. When this was persistently refused, Raman in his characteristic way said, '*I am admitting Ramachandran into my department as he is a bit too bright to be in yours!*' (another example of Raman's famous tact!—of course the tables have been turned today and computer science attracts the brighter students). Ramachandran joined physics in the fall of 1942 and a deluge of papers poured out in optics, the physics of coronae, diffraction phenomena, speckles, stratified media, photoelasticity, thermo-optic behaviour, etc. Of his Associateship thesis K. S. Krishnan said that it was worth at least two doctoral degrees! The following is an example to illustrate, the ease with which Ramachandran could absorb ideas when the slightest mention is made to him and how with lightning speed he could implement them. I vividly remember when Raman told GNR that he (CVR) had observed nonuniformities inside Laue spots which must be due to variations in the reflecting power of the crystal and felt that it should be possible to get a point to point mapping of the imperfections in a diamond plate. This took place on Friday evening before Raman left for his country estate to spend his week end. By the following Monday morning Ramachandran had not only worked out the theory, the experimental arrangement, but had actually obtained excellent *topographs* of a diamond plate (Figure 13). When he (GNR) left for Madras in 1951 he started a new field and is now recognized to be the Father of Molecular Biology in India. It is well known that many of G. N. Ramachandran's seminal contributions to physics and biology have been based on Fourier theory and the Fourier transform. In the preface of his classic book with R. Srinivasan, he states that he owes Raman his initiation into this field as well.

Solid state physics

One can with some confidence say that the Department

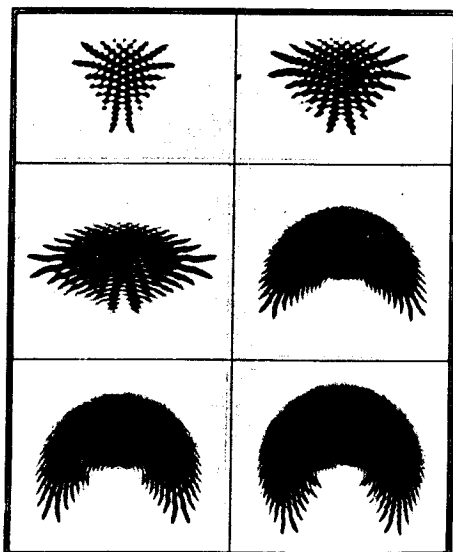
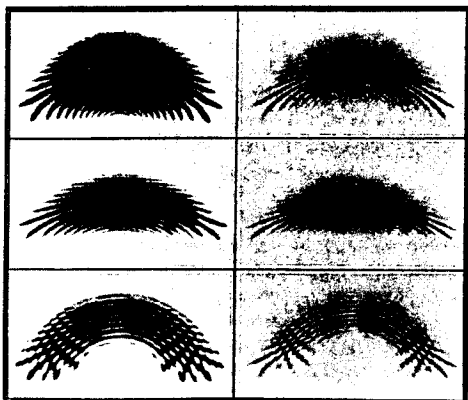
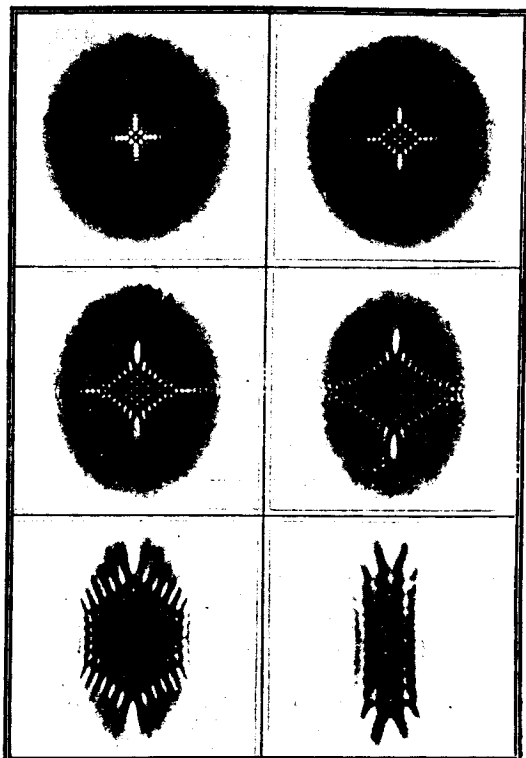
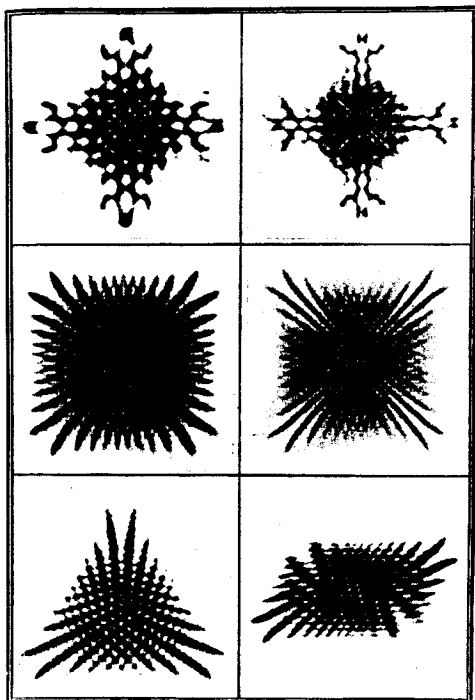

Figure 11. Fresnel diffraction patterns of different shaped obstacles. These complex patterns can easily be derived from the simple geometric theory.

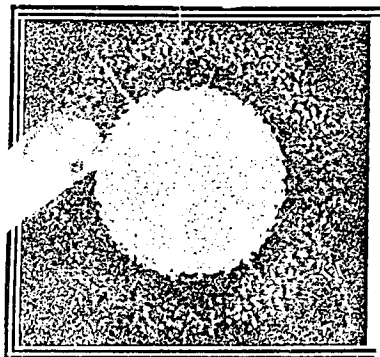

Figure 12. Speckles—granular structure in intensity in the diffraction halo (the Fraunhofer pattern) formed by lycopodium spores on a glass plate.

pioneered Solid State Physics even when this term had not been coined. C. V. Raman was convinced that diamond held a key to the understanding of the solid state. This resulted in an experimental activity never before seen in this country. New techniques and results poured out in diverse fields like thermal diffuse scattering, X-ray topography, Brillouin and second order Raman scattering, absorption and fluorescence spectroscopy, photoconductivity, piezo- and thermo-optic behaviour, the morphology and cleavage properties of crystals, etc. I shall mention a few of the results here.

The first step Raman took was to acquire material for his researches. He bought hundreds of diamond plates, scores of single crystals and dozens of diamond fragments.

(a) One of the striking features noticed was that most diamond plates showed the perfect octahedral (111) cleavage which was known to the ancient lapidaries of India. There were however many plates exhibiting (110) and (221) and other cleavages. Why do crystals show a multitude of cleavage planes and why are some more perfect than others? The energy of cleavage of a plane is that required to rupture the bonds connecting atoms on either side of it. From calculations of these energies definitive laws governing cleavage were formulated—a crystal can cleave along any plane for which this energy is a minimum; the number distribution being an inverse function of this energy; the greater the variation of this energy with direction the more perfect would the cleavage be. A study of the cleavage plates and fractured diamonds in the Raman collection validated these criteria.

(b) According to Willard Gibbs, the shapes of normal crystals having flat faces are determined by the rates of growth of these faces.

Most single crystals of diamond (especially of Indian

origin) exhibit beautiful curved faces. Just as in the case of the formation of liquid drops, it appears as though surface tension is involved during the formation of these diamond crystals. Calculation of the surface energy (i.e. half the cleavage energy) indicates that the total surface energy influences in some way the morphology in diamond. Quantitative measurement of the curvature in a different direction seems to lend credence to this idea (Figure 14).

(c) From the data acquired in the Department and the earlier work of Robertson, Fox and Martin in light scattering and infra red activity of diamond, Raman deduced correctly that the local atomic symmetry in this substance must be non-centric in some cases, centric in others and proposed that the intermingling of the two would explain many of the properties (like birefringence, blue and yellow fluorescence, X-ray topographs, etc.) which he and his group had studied. His conjecture was consistent with the symmetry assigned to diamond by the great mineralogists of yore (Groth, Hintze Dana, Miers)—the acentric ditetrahedral polar class. The X-ray crystallographers on the other hand gave it the highest symmetry—the centric holohedral class. Since X-ray diffraction is a Fraunhofer phenomenon, it introduces a centre of symmetry. Raman therefore made a morphological examination of hundreds of natural crystals of diamond and established that a majority of diamonds were indeed non-centrosymmetric. Raman therefore postulated that, two types of carbon atoms left and right handed having an intrinsic/non-centrosymmetry. It is now certain that the non-centric local symmetry in diamond is actually created by impurities like boron and nitrogen entering the diamond lattice and that there is no need for the two types of carbon atoms Raman had postulated. This would of course imply that comparatively small amounts of impurities could even affect the gross morphology of crystals.

(d) *Alpha-beta transformation of quartz—the soft mode:* Then came one of the most important discoveries made in the Physics Department—the mechanism of transformation in crystals in general and the alpha-beta transformation in quartz in particular. At 575°C T_r alpha quartz (trigonal) transforms to beta quartz (hexagonal). The transformation is well known and well studied. The thermal expansion increases with temperature and tends to infinity at T_r and then it actually drops to a negative value. The Young's modulus falls and beyond T_r rises sharply etc. The Raman spectrum and its variation with temperature was studied. Many lattice lines appear but the 220 cm^{-1} line behaved oddly. With rise of temperature it becomes weaker and weaker to become a diffuse band as T_r is approached (Figure 15). While all other intense lines continue to be visible, Raman and Nedungadi correctly conjectured that the restoring forces which determine the 220 cm^{-1} frequency diminish rapidly with

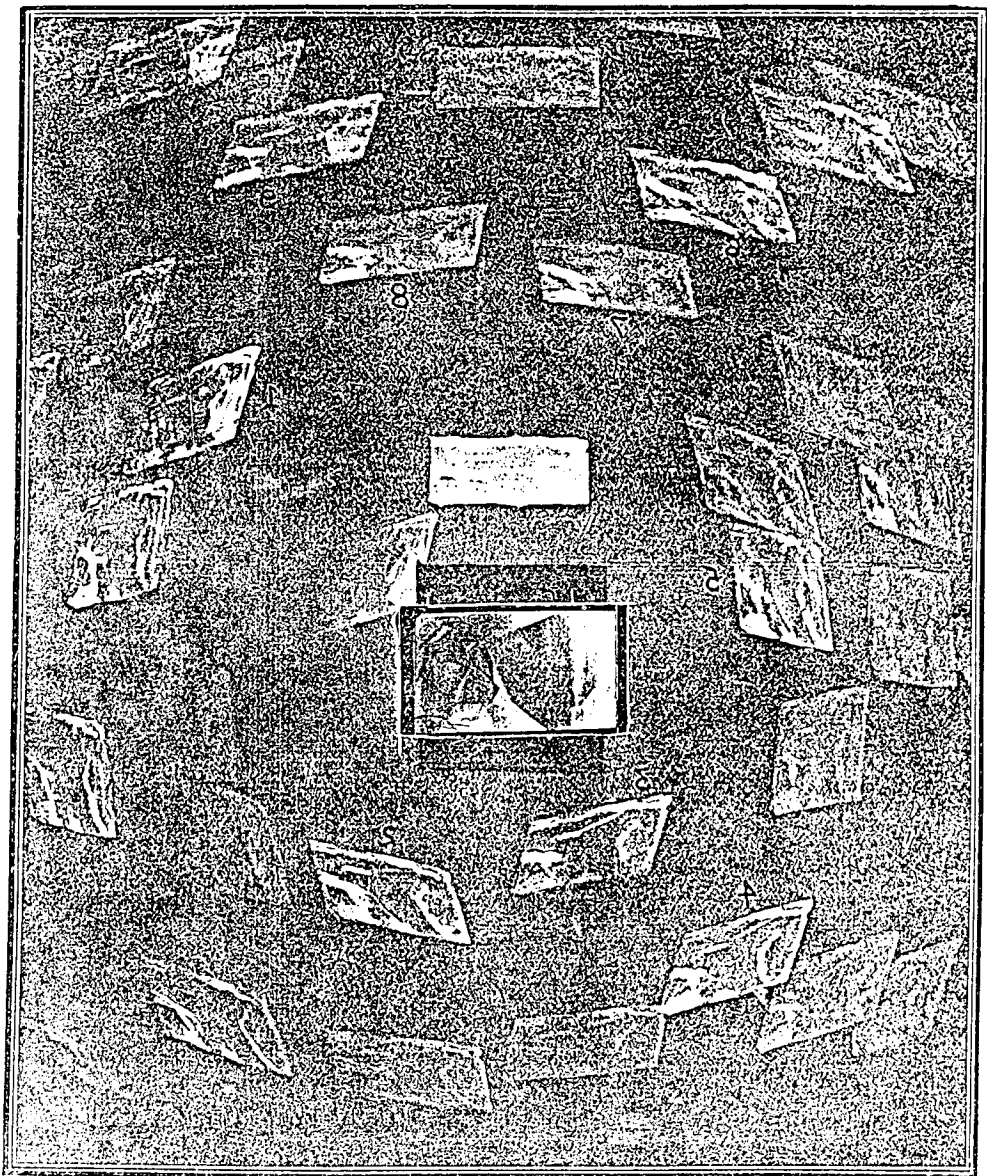

Figure 13. X-ray topographs of quartz, when taken in this manner there is a distortion. But by having a correct geometry the exact shape of the crystal can be reproduced.

increase in temperature—this in turn defines the atomic arrangement and is responsible for the alpha-beta transformation. (Bhabha who had then just joined the Department exclaimed after listening to a lecture by Raman *there is wizardry in the old man*). Twenty years later Cochran

(independently) rediscovered the mechanism in the context of ferro-electricity and it is now called the *soft mode*. As one of our prominent scientists said *the paper by Raman and Nedungadi was neither noticed nor quoted as it was published in an obscure journal called Nature!*

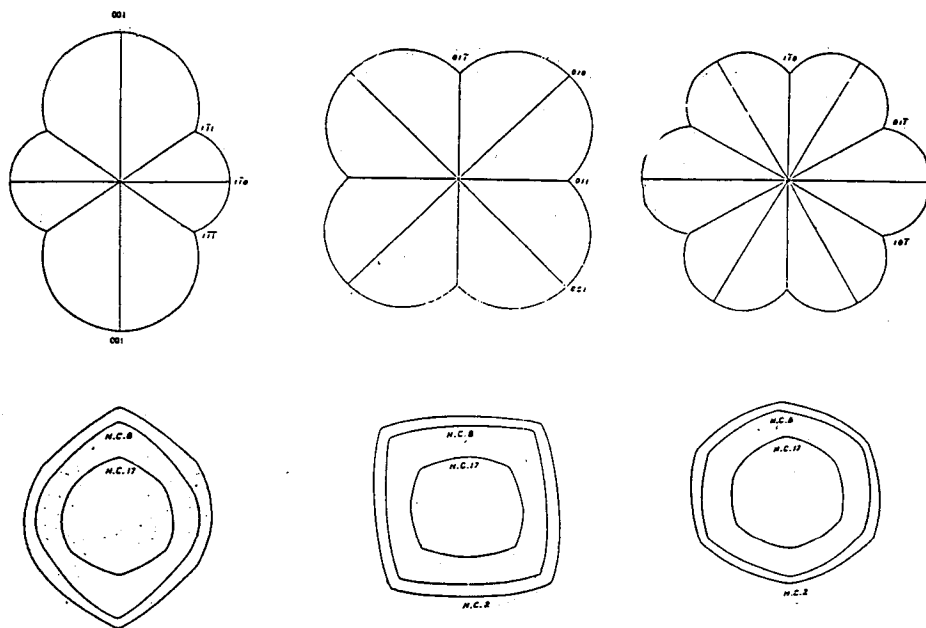

Figure 14. Diamond morphology: The shapes of curved diamonds in different zones and the corresponding surface energies. The minima represent directions of easy cleavage.

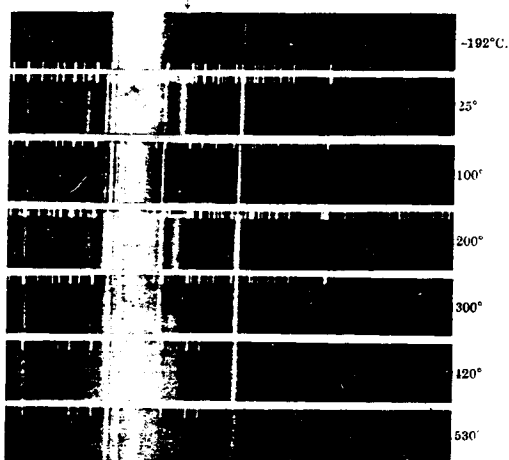

Figure 15. Light scattering in quartz at various temperatures. Note the 220 line broadening and vanishing at the temperature of alpha-beta transformation.

(e) *Thermal diffuse reflection.* It is not too well known that the thermal diffuse reflections were first discovered in the Department (and later independently by Laval in France). When X-rays fall on an atom (in a crystal) they would emit secondary radiation which would cancel in most directions but reinforce in specific discrete direction giving sharp (the Bragg/Laue) reflections. If however the atoms oscillate there would be a periodic variation of the phase of the scattered waves and the scattered frequencies will be increased and diminished by the oscillation frequency of the atom with a corresponding deviation in the direction of scattering. Debye and Waller pointed out that the effect of these vibrations would be to decrease the intensity of the Bragg reflection. There would however be another consequence. The Bangalore school pictured these vibrations as pulsations of the electron density which is equivalent to superposing a dynamic stratification on each static stratification of the crystal. The static and dynamic planes should be separable by tilting the crystal away from the exact Bragg angles—a procedure now called exploring the reciprocal lattice. Raman and Nilakantan looked for and

observed such dynamic reflection, first in diamond and later, in many other crystals. The discovery of the temperature-dependent 'non Bragg reflection' made at Bangalore was confirmed by the work of several laboratories. A temperature-independent diffuse reflection was also discovered in diamond which Raman thought was due to the excitation by an optical phonon and it became a matter of controversy.

(f) After discovering the *soft mode* and the two types of diffuse scattering, the next step was to look for better experimental methods of determining the vibration spectra of crystals.

At this stage Raman saw the remarkable photographs taken by Fermi and Rasetti in 1931, of the second order Raman spectrum of NaCl which they described as follows, *the effect is however very different from the usual Raman effect observed in crystals. It consists of a continuous spectrum over which were superposed a few apparently randomly distributed maxima and minima!* Raman discerned in these *nine lines*, exactly the number of discrete modes of the NaCl lattice which he expected on the basis of his own theory of lattice dynamics.

The Rasetti technique consisted of using the 2536.5 resonant radiation of mercury as the source, coming from a magnet controlled, water-cooled quartz mercury arc. To prevent the complete fogging of the photographic plates by the scattered radiation from incident source, Rasetti cleverly introduced a filter of mercury vapour into the scattered beam which absorbed the resonance radiation producing a clear photograph in which spectral lines could be seen as close as 50 wave numbers from the incident line! So impressed was Raman with this technique that he immediately urged his associates, first Roop Kishore, a visiting scientist, and later R. S. Krishnan to set up the Rasetti technique of recording Raman spectra. In R. S. Krishnan's skillful hands it became perhaps the best method of studying the vibration spectra of crystals till lasers and neutron scattering took over. One notes that the definitive experiments of Brockhouse on thermal neutron scattering showed clearly that the modes in Raman's crystal dynamics were a subset of Born's crystal dynamics.

(g) R. S. Krishnan using the Rasetti technique actually recorded the Brillouin scattering in diamond in a simple quartz spectrograph 'without using a high resolution attachment like the Fabry-Perot etalon' (Figure 16 a, b). At first Raman and Krishnan were so startled that they thought the doubling of the central line was due to the grilling of the photographic film. But a simple 'back of the envelope calculation' showed that because of the high velocity of sound in diamond the two Brillouin components must be seen even in an ordinary spectrograph! A second spurt of activity started in this field and the velocity of sound, longitudinal and

transverse variation with angle, variation with temperature were all measured. Perhaps one of the most elegant pieces of work in this field came from V. Chandrasekharan who showed that since the elastic modulus as well as the dielectric constant are tensors there should be 12 observable Brillouin components in a solid (Figure 16 c).

Homi Bhabha, Vikram Sarabhai and Harish-Chandra

Homi Bhabha came to India in June 1939 at the age of 29, after 10 years' stay in Europe (mostly Cambridge, England) with a long list of achievements. When the war broke out he decided to 'stay on'. After rejecting Chairs in Allahabad and Calcutta (so it is said) he came to Bangalore and saw Raman. It was love at first sight. He was offered a readership in the Physics Department. Raman proposed Bhabha to the Fellowship of the Indian Academy of Sciences and the Royal Society and he was elected to both. Raman persuaded Bhabha (i) to give a course of lectures (*on Spinor analysis*) for the written version of which he got the Adams Prize, (ii) to interact with scientists, and (iii) to take students. A slow and remarkable transformation took place in Bhabha's mental attitudes. In spite of his isolation from Europe he chose problems with discrimination and worked on new topics in quantum electrodynamics. In fact he felt the work he did in India was more satisfying than much of his earlier work in Europe! He found out how self-generating scientists in India could be; how talented the students here were and how deft the technicians trained in India were—sometimes far surpassing their counterparts in the West. He was greatly influenced by Raman's philosophy that to do good science in India one had to take advantage of the resources that were unique to this country. It was at Bangalore that Bhabha decided to do high energy cosmic-ray physics taking advantage of the highest mountains, the deepest mines and the fact that the magnetic equator passed through India. He felt good science could be done if it could be organized well. His working in the Physics Department and talking often to Raman played a vital role in converting Bhabha into an Indian, to take interest in Indian science and to sow the seeds for the birth of TIFR and what is now called BARC.

The other dreamer (and achiever) Vikram Sarabhai also came to work in the Physics Department as his father did not want him to go back to England because of the war. Cambridge recognized Raman as his research supervisor. When Vikram expressed a desire to work on *cosmic rays* Raman attracted his attention to a German paper which reported that cosmic rays made imprints of their tracks on photographic plates. Sarabhai told us in Ahmedabad in 1968 how Raman exhorted

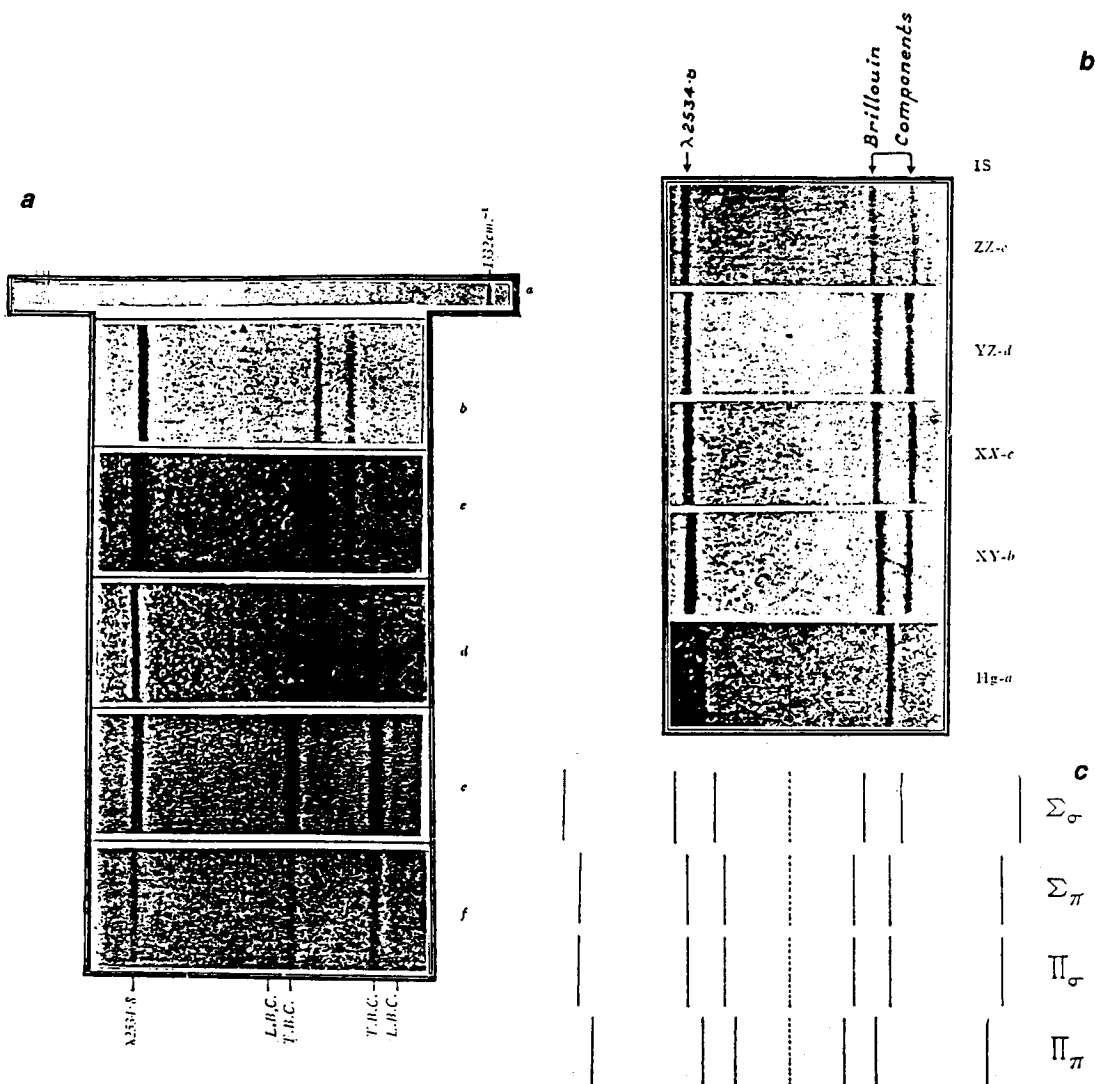

Figure 16. *a* and *b*, Brillouin scattering in diamond and quartz using the Rasetti technique and an ordinary quartz spectrograph. *c*, The 12 Brillouin components arise because of the tensor nature of elastic modulus dielectric surface taken together with the two states of polarization.

him: *This is the most appropriate technique for our country, perfect the process, fly them in balloons and study cosmic rays at high altitudes, there may still be a Nobel Prize lurking for you.* But it was Cecil Powell of Bristol and not Sarabhai who did pursue this line of research and was in fact awarded the Nobel Prize. Sarabhai too was greatly influenced by the Department

(and Raman) and went on to do many things. He established the Physical Research Laboratory, the Textile Research Institute, the Institute of Management, the National Institute for Design and also laid the foundations of space activity in India. Many of us who were in the Department have seen Bhabha and Sarabhai, gadding about the town breaking female hearts young and old—

leaving some of us green with envy. I now come to the most outstanding alumnus of the Department of Physics—Harish-Chandra who was amongst the greatest mathematicians India has produced in recent times. He wanted to work with Raman who advised him to work with Bhabha instead. A special issue of *Current Science* on Harish-Chandra has been brought out which all must read, where I have also dealt with his stay at the Institute.

Max Born was first invited by Raman to be a visiting professor to the Department. The annual report says: 'The presence of Dr Max Born during the session 1935-1936 gave a great stimulus to the work of the Department; accelerated the growth of a school of research in theoretical physics in Bangalore. The audience attending Dr Born's lectures, both in and outside the Institute benefitted greatly by his lucid exposition of physical principles in mathematical theory...' The sad story of how shabbily he was treated by the council which prevented other savants fleeing from Germany from coming to Bangalore and the sadder story of Raman being removed from the Directorship have both been dealt with in detail by G. Venkataraman in his *Journey into Light*. The interesting fact is that it was during these traumatic periods that Raman (personally) and his group did some of the most important researches that brought repute to the Department.

There were many visitors to the Department an important one being R. A. Millikan who did cosmic ray research flying balloons. This proved quite an inspiration to India to do cosmic ray research.

R. S. Krishnan takes over

C. V. Raman retired from the Physics Department in July 1948. During the 15 years when he was head, the work done and discoveries made in the Department could match those of any laboratory in the world; especially when one remembers that the number of workers was very small—most of them being doctoral students—and the resources were extremely meagre.

Raman was succeeded by R. S. Krishnan. Almost immediately the powers that be said that the Department must be shifted from the main building to a building that the Electrical Engineering department had just vacated. Since a time limit had been set for the shifting, every member of the Department, every research fellow, every student and all technical staff worked like donkeys and the entire shifting operation was done with no breakage of any equipment, costly or otherwise, with a minimum dislocation to research activity. In fact it was done so well that story went around that the research group of the physics department could more profitably open a movers' business!

In the beginning, many of the problems which had

been initiated earlier continued. Outstanding work was done in the fields of Raman effect, second order Raman scattering (R. S. Krishnan and P. S. Narayanan). The work on Brillouin scattering by Krishnan and V. Chandrasekharan can only be described a monumental.

Within two years a slow change took place in the style of functioning of the department. It was a clear break from the old traditions and in my view it set an example how science should be organized in Indian laboratories. In spite of the little resources available it was decided to expand the department and recruit a few members as research staff. R. S. Krishnan like his predecessor had a knack of picking young scientists with talent. The difference in the new set up was that he had to allot students to the research staff and encourage the growth of independent groups. Slowly but courageously Krishnan allowed the starting of many new activities in the department like geochronology, mass spectroscopy, ultrasonics, crystal properties (elasticity, thermo optics, piezo optics and magneto optics), paramagnetic and nuclear magnetic resonance and X-ray crystallography. By creating these semi-independent groups Krishnan probably *unconsciously* was responsible for breaking the Geheimrat system in which the Professor was supreme and all members of the lab worked for him. It must be remembered that even in his case all the students were registered for doctorate degrees formally under the head of the department although they were guided by other members of the research staff.

The dating of Indian rocks

This activity was initiated by V. S. Venkatasubramanian (VSV) by setting up the necessary equipment from scratch. It was path-breaking. Meticulously precise dates of the Deccan and Dharwar rocks—some of the oldest in the world, were measured and these data have stood the test of time. Again for extending these studies the first mass spectrometer in the country was built by VSV and his group. It can be said without any doubt that geochronology was established as a precise science in India by the Department of Physics. VSV co-authored a book on mass spectroscopy which was considered at that time as one of the best in the field. It was under VSV (and later E. S. Raja Gopal) that ultrasonic research came of age and the determination of precise elastic constants of solids/crystals by ultrasonic methods including the pulse echo method became a routine matter. It is a matter of great sorrow that VSV died quite young leaving a big gap in the Department.

Magnetic resonance phenomena

G. Suryan joined the department as a student and he

was one who was full of ideas and endowed with much experimental skill. He was never afraid of starting new experiments. He set up equipment for Nuclear Magnetic Resonance and Electron Paramagnetic Resonance for the first time (1950–51) with klystrons, wave guides and high frequency rectifiers bought from the post-war surplus army dumps near Calcutta. Many studies were reported in NMR and EPR one of which was the interesting studies of paramagnetic resonance in molybdenum salts. Many groups lead by Bitter Kastler, Pryce and others had evolved methods of detecting radio frequency resonance. Suryan suggested a very sensitive magneto optic method of detecting radio frequency resonance by modifying the classical experiments of R. W. Wood in sodium vapour. Suryan worked with me but he later became independent when I was asked to lead the X-ray group. One of the very elegant ideas Suryan had was to construct a machine for Fourier synthesis for X-ray crystallography. In this later work on NMR, EPR and instrumentation he was ably assisted by his students S. Krishnan and R. Chidambaram who distinguished themselves. Suryan's attention in later years turned to the study of the deep level impurities in silicon, making of ultra pure silicon for solar cells and producing silica glass for scientific equipment.

Crystal properties

Photoelasticity and thermo optics behaviour was studied first by K. Vedam (who left to join the Department of Atomic Energy) and later with great vigour by R. Srinivasan—one of the most remarkable scientists the Department has produced. It is difficult to meet any scientist in India who is more modest and yet combined in him so much experimental skill and theoretical acumen. Precise results began to pour out in these fields and they were collected and published in a compendium called *Crystal Physics* edited by R. S. Krishnan which went into many editions. Along with his students and collaborators, Srinivasan also published a series of papers on *Lattice Dynamics*. He was a repository of immense scientific knowledge and research workers, young and old, flocked around him to be inspired by his wisdom, and also to get all their experimental and theoretical doubts cleared.

Optics again—the Poincaré sphere

Because of its topology Henri Poincaré introduced a sphere to represent all states of polarization (*Poincaré sphere*). This elegant concept was taken up in India by my group for understanding magneto optic phenomena in the presence of birefringence. It was used to derive the correct Faraday rotation in diamond as most specimens

exhibited strain birefringence (V. Chandrasekharan). By inverting the process the birefringence induced by stress could be determined accurately by measuring the decrease in the Faraday rotation with stress. The variation of stress optic co-efficient with wavelength could also be measured. By such measurements it was shown that to explain the dispersion of piezo birefringence in glasses one had to invoke the splitting of the dispersion frequency by stress (V. Sivaramakrishnan). Simultaneously and independently Jog working with R. Srinivasan showed unambiguously that only this splitting could explain the stress birefringence and its dispersion in fused silica. These are important discoveries.

The Bell Laboratories reported similar results in other crystals ten years later! Another beautiful idea of V. Chandrasekharan was to measure the piezooptic co-efficients of the class of crystals that were optically active, by determining the decrease in the optical rotation with pressure (G. N. Ramachandran and V. Chandrasekharan). The Poincaré sphere played an important part in the development of optics in India. One of the central theorems in optics—the intensity of light in any state of polarization transmitted by a general elliptical analyser was derived in a simple and elegant way. Novel practical analysers for light were designed and used. Jean Perrin had pointed out that apart from the intensity reciprocity relation that had been discovered in the Physics Department—there was another related to phase. Because of the familiarity of the group with the Poincaré sphere the necessary retardation plates could be fabricated and the second reciprocity theorem in phase too was also verified (N. L. Ramanathan).

All these developments in optics were included in the definitive monograph *Crystal Optics* in *Flugge's Handbuch der Physik*.

X-ray crystallography

When G. N. Ramachandran returned from Cambridge the department planned that he should build a substantial group in X-ray crystallography. X-ray equipment was ordered from England. Awaiting its arrival Ramachandran joined in with the activities of the optics group. Meanwhile his student Gopinath Kartha determined the structure of barium chlorate monohydrate, the first one to be solved in India using modern Fourier techniques. Ramachandran was offered the chair of Physics at the Madras University and he left the Department in 1951 along with all his students including Kartha and Thathachari. It is a part of history that he established at Madras one of the most reputed Biophysics schools in the world.

An X-ray group was formed *ab initio* with me in charge: As a first step, using the electronics counting unit made by one of Ramachandran's assistants

V. Radhakrishnan (who too left), an X-ray polarimeter was built which gave many fruitful results (Figure 17). Optical activity in the X-ray region was detected in quartz and cinnabar which was about 1% of that in the visible and in the same direction. Twenty years later it was detected (independently) and measured much more accurately. A novel method of estimating the degree of perfection of a crystal by measuring the changes in the intensity of a Bragg reflection when the polarization of the incident X-rays was varied was developed. The multi wavelength X-ray anomalous scattering technique for phase determination was experimentally shown to be feasible. Near the absorption edge the real part of the scattering factor changes rapidly; hence using a series of incident wavelengths was shown to be equivalent to having a series of perfectly isomorphous crystals (Venkatesan). With the coming of the variable wavelength high intensity synchrotron X-ray sources, this method has found increasing application in structure determination. The structures of many organic compounds (aromatic and aliphatic) were determined (Venkatesan, Swaminathan). The structure of Echitamine whose structure was unknown was determined—unfortunately a week after J. M. Robertson did it in UK (Manohar).

The structures of many inorganic crystals were also obtained, some exhibiting the Jahn Teller effect (Viswamitra, Mani, Swaminathan). One of the successful exercises was to look for and to discover the Platonic solid, the icosahedron as a coordination polyhedron—which Pauling had forgotten to mention in his classical work (N. V. Mani) (Figure 18). Around many polarizable

ions it was shown that the co-ordination polyhedra were the Archimedean solids (Manohar). Low temperature crystallography using liquid air as coolant was started in the early fifties to solve the structure of the crystallized liquids; to study thermal expansion and transformation of crystals; to make measurements of the Debye–Waller temperature factors and to reduce crystals denaturing by X-rays (M. A. Viswamitra and A. K. Singh) (Figure 19). After I left (1962) Viswamitra took over and continued work till he turned his attention to biocrystallography in a big way and his school was internationally recognized for the study of oligonucleotides. From the crystal structure of d_p A–T–A–T his group derived the now famous concept of DNA double helix having sequence-dependent variability.

Some more recent scientific investigations

Critical point phenomena

Well before the explosive growth of the study of the behaviour of matter near the critical point E. S. Raja Gopal entered it and he and his group got many interesting results. Most of us know how difficult this area is, especially the need for precision, the fact that experiments could last for weeks on end, (and much longer given the constant power failures Bangalore had and has). Raja Gopal also used this area to train a very devoted band of young workers who got a taste for accuracy. Of some examples of the work from his group are: (i) the violation of the rectilinear diameter law in binary liquids, (ii) the study of the glassy state (pressure induced crystallization). These experiments have thrown some light on a few of the questions raised by J. C. Phillips on geometric versus internal degrees of freedom.

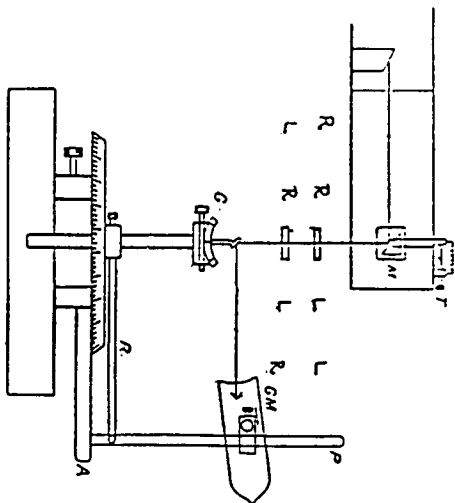

Figure 17. X-ray polarimeter to study optical rotation in the X-ray region. Two right-rotating crystals and two left-rotating crystals of exactly equal thickness are slid in the beam in the order shown. The rotation changes from $2l$ to 0 to $2r$ permitting small differences to be observed.

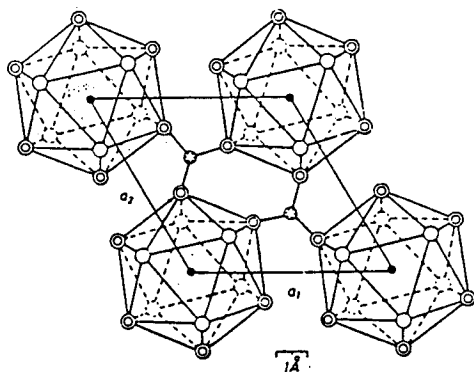

Figure 18. Icosahedral coordination of oxygen around barium in barium perchlorate.

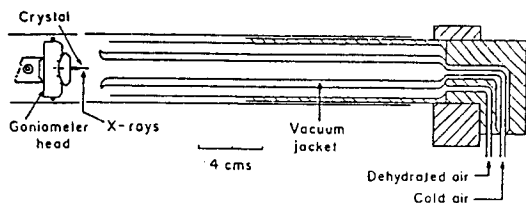

Figure 19. The simple technique of freezing liquids in Weissenberg cameras for the study of crystal structures.

NMR and ESR again

The pioneering work of Suryan in both ESR and NMR flowered into a large group when R. Srinivasan (II) entered the Department and the fray. He had much to do with the tradition that grew both of instrument building and doing physics with instruments. His experiments with high pressure NMR are considered to be pioneering. Scientists with him worked as a group whether it be in rigorous and regular discussion meetings (a tradition which I am happy to note still continues), keeping long hours—Srinivasan himself is known to have kept the longest—or in the slow migration to the canteen which became quite famous. He could be friendly and charming but also drove himself and indeed the whole department very hard as a Chairman. It was a very healthy and stimulating thing as it was done for the Department and not for any personal gain. Many of us here can contemplate what one could learn from such examples—especially since Srinivasan, like VSV, died quite young.

A new era of magnetic resonance with sophisticated custom-built equipment and large computers was also ushered in. For lack of time—but mostly lack of expertise I shall just mention the work on multi-dimensional techniques, oriented molecules, etc. (Anil Kumar Sr).

I am tempted to mention the work on Jahn Teller (JT) effect (S. V. Bhatt) as my group of crystallographers was long ago very interested in it (Viswamitra, Swaminathan, N. V. Mani). Jahn Teller effect is the spontaneous lowering of symmetry due to electronic level degeneracy. The work of this group relates to Jahn Teller effect in glasses—wherein the Jahn Teller effect at multisites produces a disordered state. As N. Kumar put it in his inimitable way, 'Symmetry produces degeneracy but degeneracy breaks symmetry'.

Novel measurements have been done of self diffusion by imposing a magnetic field gradient via broadening of the line in magnetic resonance, reminding one of the work Suryan did in the early fifties.

A recent significant discovery is the microwave absorption in high T_c superconductors. One wonders whether it is a grain boundary effect.

One-dimensional conductors

Many old timers in condensed matter physics remember the excitement caused in the early seventies by: (i) one-dimensional conductors based on charge transfer complexes (TTF-TCNQ), (ii) the switching phenomena—the Ovshinsky effect. The work in these fields often tended and even now tends to be hit and run. S. V. Subramanian not only hit, but by not running consolidated many of his experiments. He has painstakingly built up a laboratory and evolved many techniques to study transport in these materials. He is one of the very few scientists in India who has used all three variables, high pressure, low temperature and magnetic fields in his studies. One of his recent and fascinating results (*like the dog that did not bark*) is the fabrication of the film whose resistance (practically) does not vary with temperature. It still awaits a Sherlock Holmes to decode it. His experiments on charge density wave pinned to various centres or charge density wave sliding have attracted attention of experimenters and theorists.

Semiconductor laboratory

Vikram Kumar and his group continued and perfected some of the initial work by Suryan in deep level impurities in semiconductors. They set up a semiconductor laboratory which was really professional. His group carried out systematic studies of the density of states in MOS devices and of deep level interphases in bulk semiconductors (they being the most difficult to get rid of). The use of luminescence spectroscopy in semi-conductors, time-dependent capacity measurements, energy level of traps, etc. was started by this laboratory. He has now left the Department and one hopes that younger people can be found to replace him, his energy and his quiet enthusiasm.

Phase conjugation

It is so wonderful to see P. S. Narayanan at this lecture as he was seriously ill till recently. He is an unusual case of youthful vigour *behind* his time. Just when all of us had labelled him as just a routine Raman-effect ferroelectrics man he has made a come back and has carried out beautiful studies (with materials carefully prepared and supplied by Bhat) on nonlinear optical phenomena like phase conjugation. The younger ones trained by him are slowly taking over.

Critical phenomena

In conventional experiments on critical phenomena, the boundary curve in a binary mixture is approached in a

direction transverse to the curve. Under special circumstances it can be approached tangentially and the exponent doubles. These studies (Anil Kumar Jr.) are being made in the more difficult three component mixtures wherein new types of critical points (lower and upper) are possible. It seems one has gone back to studies in critical opalescence to get at the correlation length and the critical exponents.

The Raman Building

I now come to another phase of the Department. When I was invited to give this talk I asked how many groups there were in the Physics Department. The reply was, 'there are 33 faculty members and therefore there are 33 groups'. While this surprised me, I am sure that this reflects the independence given to all faculty members and does not imply lack of co-operation between the different groups.

When I had another stint at the Institute between 1979 and 1984 I did two things for the Physics Department. I was able to convince Rais Ahmad (the Deputy Chairman, UGC) that UGC should give about Rs 50 lakhs at least for an extension of the Physics building to commemorate the Golden Jubilee of the Department in 1983. The outcome is what is now called the Raman Building. The second and the more important step I took was to invite T. V. Ramakrishnan back to India—an invitation he most kindly accepted. I did not know at that time this was also the precursor to filling up the Raman building with young scientists!

The story starts in Kanpur where I heard TVR present the density wave theory of freezing (TVR and Youseff). I was greatly impressed. I am told he put up a poster at the DAE Symposium in 1975. Interestingly, the paper did not appear in the published proceedings,—perhaps at that early stage it appeared too speculative! This idea of density wave theory was done by him in India, with Indian collaboration—and it was a runaway success. Then TVR went abroad to Princeton and became a member of the 'gang' of four headed by P. W. Anderson, which produced the well-known scaling theory connected with the phenomena of localization of electrons.

The Director was keen on TVR joining, the Department and its faculty too welcomed his coming in but his entry into the Institute was not as easy as one wanted it to be. In any case, it was wonderful that he did come to India and without any fuss nucleated a very friendly group at the Department which mostly sits in the Raman building.

Few scientists can do good science; fewer still attract a group which is greater than the sum of its parts. This started happening at the Physics Department with the entry of TVR.

Young men like H. R. Krishnamurthy who were

already in the Department and others, for e.g. Arup Ray Chaudhuri, Ajay Sood, Sriram Ramaswamy, Chandan Das Gupta and Rahul Pandit joined and excellent laboratories in more modern aspects of condensed matter physics were set up. One witnessed a stream of results coming out in both theory and experiment.

TVR and his younger colleagues did some beautiful work. The density wave theory of freezing is a recipe to calculate free energies of various ordered states in terms of measurable liquid state parameters like $S(q)$ or $g(r)$ as inputs. No potential between atoms goes into the theory! In the earlier work the latent heat, Debye Waller factor, fcc, bcc energies had been calculated. Now this was extended to: (i) Strained structures were analysed and the shear moduli of different structures were obtained, (ii) defect structures from which dislocation energies including core effects were derived, (iii) interfaces and martensitic transformations were dealt with, (iv) the stability of fcc-bcc structures, (v) colloidal crystals for which $g_3(r_1, r_2, r_3)$ the triplet correlation function had to be brought in.

A few examples of the new science in the department

(a) The group set up by Arup Raychaudhuri has turned out to be a very reputed one in low temperature experimentation work. Some of their work relates to: mechanical relaxation of spin glasses, study of not only equilibrium properties (of glasses) but also the kinetics of the time-dependent specific heat which has been termed as Energy Release Spectroscopy. They have constructed a Scanning Tunnelling Microscope by which tunnelling studies on a variety of systems including high T_c oxides like La (NiCo) O_3 Ni (WHO₃) and metal insulation transition (with STM) where continuous quantum effects become important between 0–0.3 K.

(b) On grounds of personal taste more than anything else, I would like to dwell a little on the area of one-dimensional quantum transport (N. Kumar) as it has many intriguing connections with some earlier work done in the Department. At the elementary level it is connected with the speckle phenomenon (Raman and Ramachandran) where they are the violent fluctuations in intensity due to single scattering of light waves by a multitude of particles. This new study relates to multiple scattering of matter waves (of Schrödinger waves) by a random potential, which again being 'coherent' interfere to give violent fluctuations. Resistance arises due to the scattering of electron waves by atoms. Our classical intuition says that when this scattering occurs, transmission should decrease monotonically. However the idea is that when there is multiple scattering, because of the coherence between various

scattered waves-violent fluctuations in the resultant intensity would ensue. To deal with the scattering by a one-dimensional random potential Kumar makes use of the technique of imbedding which S. Chandrasekhar and Abartsumian had developed in the context of radiative transfer in astronomy. So the resistance is highly 'complexion-dependent'—to use the term coined by Boltzmann. In the quantum picture resistance has a broad probability distribution. The net result is that in quantum wires of extremely small thicknesses: (i) resistances do not add, (ii) macroscopically identical samples can have different resistances i.e. there is a large sample to sample fluctuation, (iii) average resistance can vary from zero to infinity! Indeed Kumar who has a speculative mind also connects all this to the possible mapping of DNA by measuring the quantum resistance of a single strand!

The other topic which I touch upon is the work on Diffusion Wave Spectroscopy (Sood, Kumar, Sriram Ramaswamy and others) i.e. multiple-inelastic scattering in colloids. Here again I see this work connects with the earlier work in the Department: (i) colloid scattering, (ii) speckles, and (iii) the Poincaré sphere. The work relates to scattering of light from colloidal polycrystals prepared in a special manner with particle size about 0.1 microns and lattice spacing about 0.5 microns. When laser light with *vertical polarization* is incident on such a crystal it undergoes scattering by a series of phonons and the outgoing beam has in it, apart from a vertical component, a horizontal component also. This horizontal component carries with it information on: (i) anisotropy: in an assembly of spherical particles anisotropy can even arise from 'form birefringence' (cf Bragg theory of birefringence), and (ii) multiple scattering: since the scattering phenomenon is coherent something like a speckle phenomenon results.

The experiment consists of measuring the intensity correlations of the two polarisations of the scattered light (the Hanbury Brown and Twiss method of intensity interferometry). Without going into details one can say that the vertical component behaves as though scattering is in a solid where the time for decorrelation is limited. The horizontal component is very sensitive to anisotropy, and in multiple scattering, every occasion there is scattering at a colloidal particle the polarization changes. To my mind the simplest way of explaining what happens is to say that during multiple scattering the point representing the polarization on the Poincaré sphere makes a random walk. Much information about these soft 'crystals' may emerge from diffusion wave spectroscopy.

The influence of the Department

A question that is always in ones mind is whether an institution has had an influence on the country and on

science as a whole. My answer in respect to the Physics Department is a resounding yes. I shall illustrate this by using X-ray crystallography as an example. G. N. Ramachandran who owed so much to the Department of Physics set up the first biophysics school at Madras and it also turned out to be one of the best in the world. Gopinath Kartha, one of our Ph D students, went on to solve the collagen structure in Madras with GNR and then when he went to USA he was mostly responsible for solving the structure of the protein ribonuclease. He was also (unfortunately) responsible for attracting many of the best students of G. N. Ramachandran from Madras to the USA! R. Chidambaram went to Bombay to set up a very reputed school of neutron crystallography for which all the instrumentation was built in India. I am quite proud that many of my students also contributed much to the spread of crystallography. Venkatesan set up one of the best groups in organic crystallography in India, and he and his group have made significant contributions to the study of solid state photochemistry. His students (from the Institute) have spread far and wide doing excellent work in India and outside. One of his Ph D students, again from the Institute, M. R. N. Murthy, has pioneered virus crystallography in India. My student Manohar turned to inorganic chemistry and the work of his groups on topotactic reactions can be called pioneering. We have already dealt the work with M. A. Viswamitra which has received international recognition. Two students of the Department Vijayan and Kannan head groups of protein crystallography in Bangalore and Bombay. Two others A. K. Singh and Kalyani Vijayan have an excellent applied crystallography group at the National Aerospace Laboratories, Bangalore. Similar stories can be told in which members of the Department sowed seeds of their fields in different places in India.

What of the National scene? Three Chairmen of the Atomic Energy Commission have worked in the Department—Homi Bhabha, Vikram Sarabhai and R. Chidambaram. Vikaram Sarabhai was also Chairman of the Space Commission and the Director of Physical Research Laboratory, Ahmedabad. The Founder-Director of the National Aeronautical Laboratory, P. Nilakantan, was a student in the Physics Department. The Founder of the Raman Institute, C. V. Raman who contributed greatly to the Department and the next two Directors of RRI, V. Radhakrishnan and N. Kumar were in the Physics Department. The director of the Inter University Centre, Indore, R. Srinivasan; the Director of the National Physical Laboratory, Delhi, E. S. Raja Gopal; the Director of the Solid State Physics Lab., Delhi, Vikram Kumar were all in the Department. One of the alumni even became the Director of the Indian Institute of Science. The list goes on and on.

From the sidelines I have been noticing that in the

CONDENSED MATTER SCIENCE - CURRENT STATUS AND PLAN FOR ACTION

last few years a renaissance is taking place in the Department. There is a new spirit amongst the younger group. What is striking to an outsider (I am almost an insider) is the way collaborations have naturally evolved in recent years on specific problems; the way bright young students have interacted freely with many faculty members and learnt different kinds of physics, different styles of working ranging (in theoretical work) all the way from exact analytical solutions to large scale supercomputing. One notes with some happiness that new and innovative experimental techniques are coming in as a matter of course and young scientists are not afraid to do new things. A high level of international com-

petitiveness (the buzz word these days) has been built up as measured by the now fashionable unit of *Physical Review Letters*!!

I am not certain whether this Department will produce the *National Administrators* of the type I have mentioned in a previous paragraph but I have no doubt at all that this Department will produce good scientists and excellent science.

May I express the hope that this Department will not only consolidate what they have gained but also establish a new style and identity which is uniquely theirs for which they will be known in the years to come.
