

S3-7 Addressing Techniques for RMS Responding LCDs — A Review

T. N. Ruckmongathan

Asahi Glass Co., Ltd., Yokohama, Kanagawa, Japan

(On leave from Raman Res. Inst., Bangalore, India)

ABSTRACT

The developments in the field of addressing techniques along with their relevance to the fast STN LCDs is discussed. A new method for displaying a large number of gray shades in RMS responding LCDs in combination with these addressing techniques is proposed.

INTRODUCTION

The performance of the display depends on the display cell parameters and the addressing technique used for driving the display. The addressing techniques based on line by line selection [1,2] are widely used for driving the display due to their inherent simplicity. The fundamental assumption in these techniques is that the period of the addressing waveforms is small as compared to the response times of the display. Hence the small address duty factor is not a serious problem. However as the response times of the display decrease, the frame response phenomenon becomes predominant and it is necessary to find an alternate approach to drive the displays.

BACKGROUND

Addressing Techniques:

Important developments in the field of addressing techniques are summarized below:

In the analysis of scanning limitations of LCDs by Alt and Pleshko [1]; the selection ratio was maximized. This was possible by allowing the instantaneous voltage across an OFF pixel to exceed the threshold voltage (V_{th}) and yet maintaining the RMS voltage below V_{th} . The maximum selection ratio is given by

$$V_{on}/V_{off} = ((N^{1/2}+1)/(N^{1/2}-1))^{1/2} \quad (1)$$

wherein N is the number of rows multiplexed.

In the addressing technique proposed by Kawakami et al. [2] the supply voltage for the drivers was reduced without altering the effective waveform across the pixel. A reduction of nearly 50% is achieved when N , the number of lines multiplexed is large.

In the analysis of ultimate limits for addressing RMS responding LCDs by Nehring and Kmetz [3] the upper limits on selection ratio were derived. Waveforms to increase the selection ratio by 24% when $N=2$ were proposed. It was also shown that the selection ratio

given by equation (1) is the practical limit when N is large and displayed pattern is general; by considering the orthogonal functions.

Multi-Line selection technique was first proposed by Madhusudana et al. in the year 1979 [4]. The Binary Addressing Technique (BAT) needs only two voltage levels in the addressing waveforms as shown in Fig.1. All the rows in the matrix were simultaneously selected using two voltage levels. The column voltages were generated by using EX-OR gates. However the column voltages were limited to two voltage levels to reduce the supply voltage. This technique is based on Rademacher functions which are orthogonal.

The concept of selecting the rows in small subgroups using three voltage levels in the row waveforms was proposed in the year 1983 [5]. Again only two voltage levels were used in the column waveform of Hybrid Addressing Technique (HAT). Both BAT and HAT has lower selection ratio as compared equation (1), since the number of voltage levels in the column waveform is limited to two.

The Improved Hybrid Addressing Technique (IHAT) [6] proposed by the author in the year 1988 has the maximum selection ratio given by equation (1). It was shown that a good reduction in the supply voltage for any N can be achieved when the number of rows that are selected simultaneously (L) is $N^{1/2}$. Figure 2 shows the typical addressing waveforms of IHAT when $L=3$. The row waveform uses pseudo random binary sequence (PRBS), which is one of the many possible solutions to achieve good brightness uniformity of pixels. The Rademacher function can also be used in

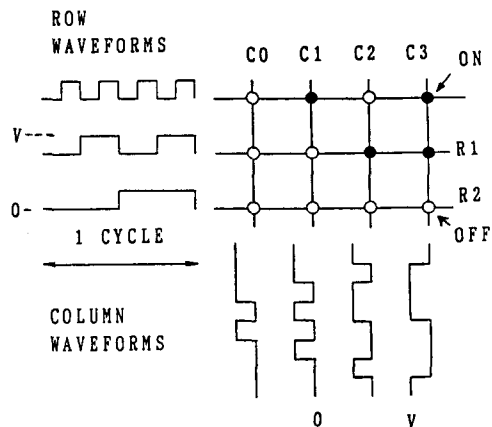

Figure 1. Typical waveforms of BAT, N=3.

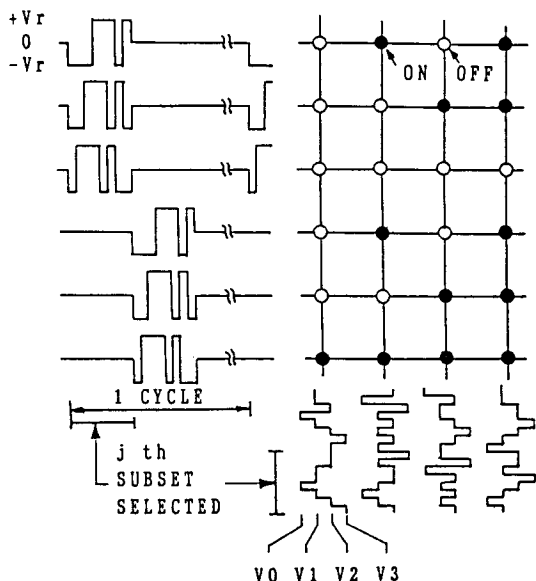

Figure 2. Typical waveforms of IHAT, L=3.

the row waveforms. Several variations of IHAT like IHAT-S4 [7] have also been proposed to reduce the supply voltage, hardware complexity and cost.

Frame Response Phenomenon:

In the conventional addressing technique the amplitude of the voltage across a pixel is large when the corresponding row is selected. The time interval between two row select pulses is also large since the address duty factor is $1/N$. Both these factors contribute to the frame response phenomenon. The large pulse increases the transmission of OFF pixels and the long time between two successive pulses decreases the transmission of ON pixels. Hence the contrast ratio of the display is decreased [9].

From this it is clear that the amplitude of the voltage across the pixel should be as small as possible and the time interval between the select pulses should be small to suppress the frame response phenomenon.

Addressing Techniques for Fast STN LCDs

Active addressing technique (AAT) proposed by Scheffer and Clifton [8] is effective in suppressing frame response phenomenon. The address duty factor is unity, since all the rows are selected simultaneously as in BAT. The Walsh function is the basis of AAT as compared to Rademacher function in BAT. The number of voltage levels in the column waveform of AAT is $N+1$ (241 levels for $N=240$) and has been reduced to relatively smaller value (45 levels) by

taking the statistics of the signal in to consideration. Hence analog TFT LCD drivers are used in AAT. Sixty four gray shades has been demonstrated using this technique.

Multi-line selection technique was used to drive a Fast responding STN LCD by Ihara et al. [9] It was shown that selecting 3 rows at a time was adequate to suppress the frame response. The addressing waveforms are similar to that of IHAT and only 4 voltage levels are necessary in the column waveforms.

Sequency Addressing Technique (SAT) proposed recently [10] is based on multi-line selection. The Hadamard matrices is the basis of this technique as compared to Rademacher functions in IHAT. The frame response phenomenon can be suppressed effectively and the technique is suitable for displaying limited number of gray shades using cycle modulation.

CHOICE OF ADDRESSING TECHNIQUE

The addressing techniques should satisfy the following requirements:

- 1) The selection ratio must be maximum to achieve good contrast in the display
- 2) The frame response must also be suppressed effectively for a high contrast in the display.
- 3) The brightness uniformity of the pixels is important for good appearance and gray shade capability of the display.
- 4) The amplitude of the addressing waveforms should be low to suppress the frame response and to reduce the supply voltage of the drivers.
- 5) High address duty factor to suppress the frame response.
- 6) The hardware complexity of drive electronics should be minimum to reduce the cost.
- 7) DC free operation to ensure long life of the display.
- 8) Gray shade display capability in combination with one of the methods to generate gray shades in the LCDs.

The conventional addressing technique [2] is suitable for driving slow responding LCDs and can achieve limited number of gray shades in combination with frame modulation or pulse width modulation. The IHAT and SAT can be used to suppress the frame response in fast responding LCDs with some increase in hardware as compared to the conventional addressing technique. The only difference between the IHAT and SAT is the row select sequence used and hence the number of time intervals in a cycle. The number of time intervals in a cycle is

about 2N (including dc free condition) for SAT. The principle of frame modulation when extended to SAT is called cycle modulation [10]. The cycle modulation can be used to display eight gray shades without any flicker in fast STN LCDs.

A new method for generating a large number of gray shades in combination with any addressing technique is proposed in the following text.

DISPLAYING GRAY SHADES

The Pulse width modulation and Frame modulation can be used for generating shades in LCDs. However the number of gray shades is limited in both these approaches. Alternatively the amplitude of the column voltage can be varied to achieve a large number of gray shades as shown below.

AM-APT

The principle of AM modulation is outlined here for the conventional Alt & Pleshko technique (APT).

The RMS voltage across a pixel in APT is as follows:

$$V_{pixel} = ((V_r + V_c)^2 + (N-1)V_c^2) / N)^{1/2} \quad (2)$$

wherein V_r and V_c are amplitude of the row and column voltages respectively. It is important to note that the amplitude of the column voltage is same and only the sign (phase) is changed depending on the data to be displayed. If the amplitude of the column voltage corresponding to a pixel is changed to kV_c ; $-1 < k < +1$ for displaying some gray shade between ON and OFF the RMS voltage across the pixel becomes :

$$V_{pixel} = ((V_r - kV_c)^2 + (N-1)V_c^2) / N)^{1/2} \quad (3)$$

However the RMS voltage across the other pixels in the same column is :

$$V_{pixel} = ((V_r + V_c)^2 + (kV_c)^2 + (N-2)V_c^2) / N)^{1/2}$$

It is clear from the above expression that when we try to change the RMS voltage of one pixel the RMS voltage of all the pixels in that column is changed. This is not desirable and the column voltage should be such that the second term (corresponding to the voltage across the pixels in the unselected rows) must be constant. This is possible by choosing the column voltage to be $(k+(1-k^2)^{1/2})V_c$ in one time interval and $(k-(1-k^2)^{1/2})V_c$ in another time interval and the RMS voltage across a pixel is :

$$V_{pixel} = ((2V_r^2 - 4kV_rV_c + 2NV_c^2) / 2N)^{1/2} \quad (5)$$

In the above expression the RMS voltage across the selected pixel is altered without changing the RMS voltage across

the other pixels in the same column. The Selection Ratio is maximum for $V_r = N^{1/2}V_c$ and the maximum SR. is :

$$SR = ((N^{1/2} + 1) / (N^{1/2} - 1))^{1/2} \quad (6)$$

same as the conventional technique. The amplitude of the column voltage depends on the gray shade to be displayed and is $\pm 2^{1/2}V_c$; wherein V_c is the amplitude of the column voltage when the pixels are driven to bilevel ie. ON or OFF only. The addressing waveforms of AM-APT are shown in Fig.3. The electro-optic response curves when AM-APT is used for generating gray shades is shown in Fig.4.

The addressing waveforms can also be modified to reduce the supply voltage as in the case of APT[2] by shifting the row and column waveforms by $+2^{1/2}V_c$ when the row select pulse is positive and by $+N^{1/2}V_c$ when the row select pulse is negative.

AM-SAT

The principle of amplitude modulation is based on applying Parsavel's theorem to the addressing waveforms since orthogonal waveforms are used for scanning the matrix LCDs. The principle of Amplitude Modulation can be extended to the SAT to obtain large number of gray shades in fast responding STN LCDs without any flicker. Fig.5 gives the photograph of typical waveform across a pixel for AM-SAT. Fig.6 gives the trans-

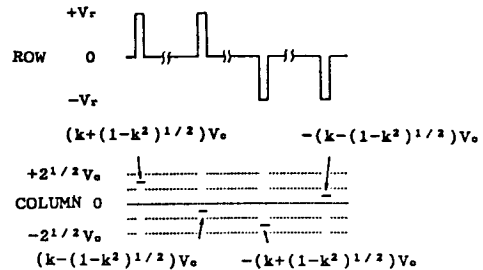

Figure 3 Addressing waveforms of AM-APT.

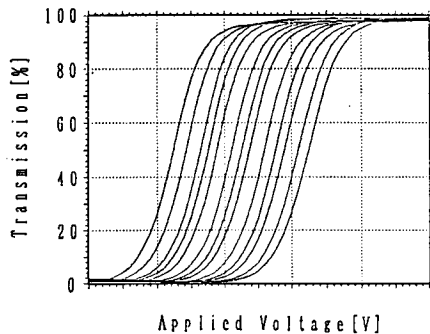

Figure 4. Transmission curves of AM-APT.

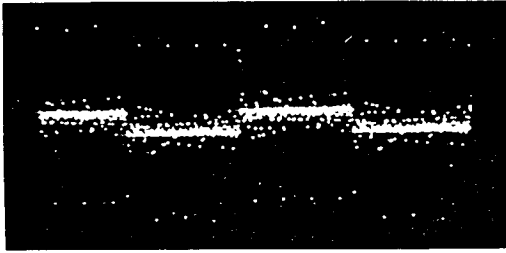

Figure 5. Typical waveform of AM-SAT.

mission vs k ; when $-1 < k < +1$ wherein $k=-1$ and $+1$ correspond to ON and OFF pixels respectively.

Table 1 gives the response times of a fast responding cell when the switching takes place between eight equally spaced gray shades and the driving waveform of AM-SAT. The upper triangle in the table represents the rise time and the lower triangle shows the fall time. The time taken to switch from any gray level to another varies in the range of 50 mS to 115 mS , a factor of two as compared to a factor of three or four in the case of active matrix TN-LCDs.

The amplitude modulation may also be extended to IHAT and the large number of time intervals is not a disadvantage in this case since only two cycles are necessary for generating arbitrary number of gray shades. Analog TFT LCD drivers can be used to generate the large number of voltage levels in the column waveforms, when Amplitude Modulation is used to generate gray shades.

A capability to generate a large number of gray levels, flicker free operation and fast switching between gray levels are some of the advantages when the amplitude modulation is used for gray scale in combination with any addressing technique. The hardware complexity is more as compared to cycle modulation with addition of column voltage generation circuit , D/A converter and the analog TFT LCD drivers used for amplitude modulation.

CONCLUSION

Amplitude Modulation proposed in this paper can be used in combination with any addressing technique for RMS responding LCDs. The relatively short time taken to switch between gray shades and the possibility of obtaining a large number of gray shades without any flicker are the advantages of Amplitude Modulation.

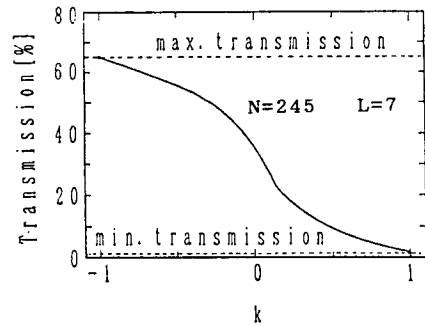

Figure 6. Transmission vs k for AM-SAT.

Table 1. Response times (mS) between gray shades in AM-SAT.

	0	1/7	2/7	3/7	4/7	5/7	6/7	1
0	-	97	109	111	115	108	95	66
1/7	57	-	99	103	105	99	85	61
2/7	54	88	-	85	97	94	80	56
3/7	51	84	83	-	100	94	82	58
4/7	52	84	92	104	-	101	79	53
5/7	56	88	98	106	113	-	57	48
6/7	55	84	95	102	102	75	-	51
1	60	86	97	104	101	90	82	-

REFERENCES

- [1] P.M.Alt and P.Pleshko, IEEE trans. ED, vol. ED-21, pp 146-155, 1974.
- [2] H.Kawakami, Y.Nagae and E.Kaneko, SID-IEEE Record of Biennial Display Conf., pp 50-52, 1976.
- [3] J.Nehring and A.R.Kmetz, IEEE trans. ED, Vol. ED-26 pp 795-802, 1979.
- [4] N.V.Madhusudana & T.N.Ruckmongathan, Proc. of Int. Liquid Crystals Conf., Bangalore 1979, edited by S.Chandrasekhar, Heyden, London pp 499-503, 1980.
- [5] T.N.Ruckmongathan & N.V.Madhusudana, Proc. of the SID Vol.24/3, pp 259-262, 1983.
- [6] T.N.Ruckmongathan, 1988 IDRC, pp 80-85, 1988.
- [7] T.N.Ruckmongathan, 'Some New Addressing Techniques for RMS Responding Matrix LCDs', A thesis submitted to Dept. of Electrical Communication Engineering, Indian Institute of Science, 1988.
- [8] T.J.Scheffer and B.Clifton, SID 92 Digest, 1992.
- [9] S.Ihara et al., SID 92 Digest pp 232-235, 1992.
- [10] T.N.Ruckmongathan et al, 'An Addressing Technique for Fast Responding STN LCDs', Japan Display 92.