

Geometric phase in interference experiments

Rajendra Bhandari

Raman Research Institute, Bangalore 560 080, India

General background

The phase of a wave, treated as a physical variable, has properties that have always intrigued physicists, particularly so in quantum mechanics. A common situation where the phase appears as an important variable arises in eigenfunction problems both in classical and quantum physics where the phase being equal to an integral multiple of 2π provides the eigenmode condition. For the past decade or so, physicists have been excited about situations where the total phase change in a process contains a piece which is not intuitively very obvious. This is the piece that has come to be known by the name 'geometric phase' or more popularly as the 'Berry's phase'.

The roots of this concept go back to a piece of work by S. Pancharatnam on interference of polarized light propagating through birefringent crystals¹ during the course of which he arrived at two extremely important results. The first of these has to do with the question: How does one define a phase difference between two light waves which are in different polarization states? Pancharatnam concluded that the most reasonable definition would be phase of the complex number $\langle \psi_2 | \psi_1 \rangle$, where $|\psi_1\rangle$ and $|\psi_2\rangle$ stand for the two-component complex vectors defining the two polarization states. With this definition, the two waves are in phase when the intensity resulting from their superposition is maximum and it represents the quantity naturally measured as the phase difference in an interference experiment. The second important result of Pancharatnam had to do with the anholonomy or the nonintegrable nature of the phase associated with a light wave when it is cycled through a circuit in the polarization space, namely the Poincaré sphere (PS). The latter is a very powerful geometrical representation for any two-state system and was used extensively by Pancharatnam in his studies¹. In the context of light polarization, this has been reviewed by Ramachandran and Ramaseshan². Pancharatnam's second result can be stated as: if a beam of light is taken along a closed circuit on the PS formed by joining n points on the PS by means of geodesic arcs, the beam acquires an extra phase equal to half the solid angle subtended by the closed circuit on the PS at the centre of the sphere. Both these insights of Pancharatnam went totally unnoticed both at home and abroad. See for example ref. 3, a paper

dealing with the same issues and written from the same institute!

One way to see the counterintuitive nature of the geometric phase is to ask the following, somewhat intriguing sounding question: 'Can one rotate a pencil about itself without ever rotating it about itself?' A less intriguing way of asking the same question would be 'Can one, with the help of a sequence of rotations applied to the pencil, none of which have a component of rotation along the axis defined by the instantaneous direction of the pencil (considered as a vector in space), bring the pencil back to its original direction in space, but rotated about itself (Figure 1 a)?'. The answer is yes. This can be demonstrated with the help of a simple gadget shown in Figure 1 b. The successive segments of the strip represent the successive orientations of the pencil and transport of the plate along the three bends 1, 2 and 3 represents a sequence of three rotations applied to the pencil. Notice that the structure of the strip and the slit ensures that at each bend, the transport is equivalent to a rotation about an axis perpendicular to the plane defined by the two segments that meet at the bend. Such a transport is called 'Fermi-Walker transport'. With this transport, the constraint that the pencil never rotates about itself is satisfied. It is easy to see that at the end of the transport through the three bends, the plate rotates about its normal, i.e. about the original direction of the pencil represented by the segments A and A' through 90° .

To see the result as a geometric phase, let us represent the instantaneous direction of the pencil (i.e. the instantaneous direction of the tangent vector to the spacecurve formed by squashing the width of the strip to zero) by a point on the sphere of directions in space as shown in Figure 1 c. The transport is then represented by the three geodesic arcs 1, 2 and 3; the arcs being geodesic as a result of the constraint of Fermi-Walker transport. Under these conditions, the net angle of rotation of the plate P is given by the solid angle subtended by the area ABCA at the centre of the sphere. If one now replaces the 'rotations' in the above illustrations with unitary transformations and the state space with the projective Hilbert space of quantum mechanics, one gets the equivalent formulation of the geometric phase in quantum mechanics, since the 'rotation' of a state about itself is equivalent to its multiplication by a phase factor.

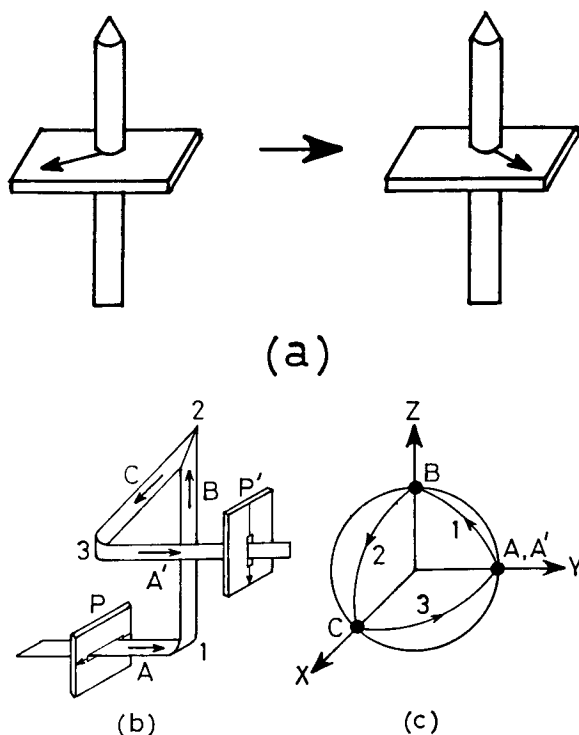

Figure 1. *a*, The initial and the final states of the pencil; *b*, 'The Fermi-Walker transporter', a gadget to demonstrate the geometric 'phase' acquired through Fermi-Walker transport; *c*, The 'sphere of directions'. The tangent to the space curve in Figure 1 *b* at each point is represented by a point on the sphere. Transport around a bend is represented by a geodesic arc when the Fermi-Walker constraint is satisfied.

The above demonstration yields yet another useful insight. In general relativity, the Fermi-Walker transported frame of reference is often called the 'non-rotating frame'⁴. The present demonstration shows that this frame (the plate *P*) in fact rotates. It is also worth pointing out that in the geometric phase literature 'Fermi-Walker transport' is almost always referred to as 'parallel transport', a practice also followed in the rest of this article.

This memorial issue on Pancharatnam would perhaps be nonexistent if it were not for an extremely insightful piece of work by Michael Berry⁵ nearly a decade ago in which he discovered a similar anholonomy of phase in quantum adiabatic evolution. Pancharatnam's work was then recalled by Ramaseshan and Nityananda⁶ and by Berry⁷ who identified the Pancharatnam phase with the phase in adiabatic evolution found by Berry. Soon after Berry's paper, Aharonov and Anandan⁸ showed that a geometric phase is associated with any cyclic quantum evolution, not necessarily satisfying the adiabatic constraint. From this it follows, and is particularly easy

to see in the case of a two-state system, that the adiabatic phase found by Berry and the phase found by Pancharatnam are, in a sense, the two opposite limits of the nonadiabatic geometric phase defined by Aharonov and Anandan⁸. Berry's geometric phase is associated with a large dynamical phase, while Pancharatnam's geometric phase has zero dynamical phase associated with it since the situation considered by Pancharatnam naturally results in pure parallel transport (geodesic evolution) on the PS.

The relevance of Pancharatnam's two observations to an arbitrary quantum evolution, which could also be noncyclic and nonunitary was shown in a paper by Samuel and Bhandari⁹. A counterpart of Berry's phase in classical dynamics was found by Hannay¹⁰. An instructive way of deriving the classical 'Hannay angle' from Berry's phase via the coherent states of a quantum system was shown by Ghosh and Dutta Roy¹¹. This proof provides the basic ingredients for understanding the nonadiabatic geometric phase seen in classical optics experiments.

Berry's paper was followed by an intense activity in experiments to demonstrate the existence of the geometric phase. The early experiments, e.g. the experiment of Bitter and Dubbers¹² with neutrons, tried to reproduce the adiabatic situation. However, as pointed out recently by Wagh and Rakhecha¹³, going to the adiabatic limit to see the geometric phase is counter-productive. It is like deliberately adding a large noise in the experiment (dynamical phase) to mask the small effect one is after, namely the geometric phase. Moreover, these experiments measure the rotation of the neutron polarization caused by the equal and opposite phases acquired by the two orthogonal eigenstates of hamiltonian and not the phase acquired by the neutron waves directly. The first optics experiment of Tomita and Chiao¹⁴ which measured the geometric phase, again as an angle of rotation of the linear polarization of a light wave traversing a coiled optical fibre, had the beautiful feature that the absence of the dynamical phase accompanying the evolution of the polarization (geodesic evolution on the sphere of directions) was ensured by the natural law of propagation of light along single mode optical fibres, namely that of Fermi-Walker transport. As often happens in science, precisely such a rotation of the plane of polarization of a light ray travelling along a curved path in an inhomogeneous medium had been predicted earlier by Vladimiriirsky¹⁵ using essentially the idea of parallel transport.

The first experiment that directly demonstrated a geometric phase (as opposed to a rotation) in an interferometric experiment was reported by Bhandari and Samuel¹⁶. This was in fact the phase predicted by Pancharatnam. This was followed by a number of experiments by different groups¹⁷⁻¹⁹ to observe various aspects of the geometric phase in polarization transformations. A useful byproduct of these experiments where

mirror reflections were involved in an essential way, was a method for analysis of mixed propagation of light beams in polarization and direction²⁰.

The instrument used in our experiments was a Hewlett Packard laser interferometer system, a custom built instrument designed for accurate measurement of large lengths in terms of wavelength of light. This system, used at RRI for the fabrication of a radiotelescope antenna, was adapted for situations where the phase shifts between the two beams of the interferometer is caused by a sequence of polarization transformations in one or both beams resulting from their passage through polarization transforming elements like quarterwave plates (QWPs), halfwave plates (HWPs), polarizers, etc. The main advantage of this instrument is the quick and accurate measurement of fringe shifts made possible by a heterodyne technique that transfers the optical phase shift on to a microwave which is then measured, along with its sign, to an accuracy of $\lambda/20$, recorded by an on-line desktop calculator and plotted by an on-line plotter. These features not only made possible the measurement of several curious and counterintuitive features of such phase changes but also helped focus on features of the phase change which are normally missed when interference effects are studied by means of a fringe pattern which looks identical after a shift of 2π . An important feature introduced in the modified interferometer in the later experiments is the absence of the polarizer that brings both interfering beams to the same state of polarization before superposition.

The unbounded geometric phase

The first curious feature of spinor phases was revealed in an experiment in which the phase change between two beams of the interferometer was monitored as a function of the rotation angle of an HWP sandwiched between two fixed, identically oriented QWPs, the incident light being linearly polarized at 45° to the fast axis of the QWPs²¹. The result of this measurement is shown in Figure 2. The interesting feature is the fact that the phase shift does not come to zero after a full rotation of the HWP but continues to increase linearly. Such a behaviour of the phase shift as a function of pure rotation of an optical element cannot be reproduced by the usual kind of optical phase shifts that do not distinguish between the two polarizations.

The other interesting feature of such phase changes is that the average slope of the phase curve like the one in Figure 2 can only take discrete values. This has to do with the fact that the net phase change resulting from a rotation through $2n\pi$ must be equal to an integral multiple of 2π . This is a signature of the topological nature of the phases.

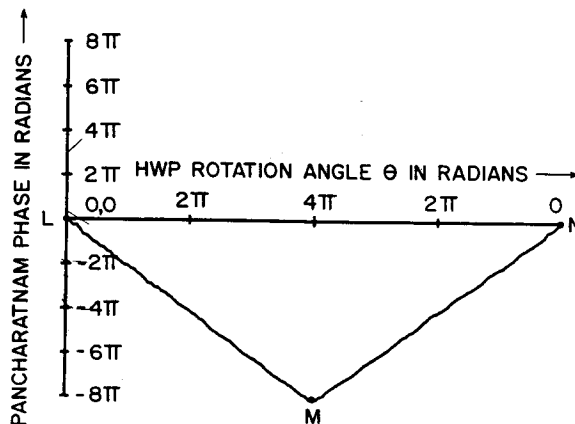

Figure 2. Observed variation of the phase of the measurement beam as a function of the angle of rotation of the HWP in a single, unbroken phase measurement. Theoretically predicted curves are the straight lines LM and MN. The first half of the curve represents rotation of the HWP in one sense and the second half, a rotation in the opposite sense.

Phase jumps

The fact that phase changes arising from spinor transformations can show a highly nonlinear and discontinuous behaviour was discovered²² by asking the following simple question²³: 'What is the observed phase change resulting from rotation of a fullwave plate through 90° in front of x -polarized light starting with its fast axis being aligned with the x -direction and ending with its being aligned with the y -direction, the reference beam being in the x -polarized state?' The nearly universal first answer to this question is 2π . The true answer, however, is very different. The expected phase change in such an experiment can be computed using Pancharatnam's criterion for the phase difference between two different polarization states. Figure 3 shows the computed phase change resulting from rotation of a waveplate with retardation δ . One sees that the phase change becomes highly nonlinear and discontinuous in the region near $\delta = \pi$, changing sign at $\delta = \pi$. For a fullwave plate, the expected phase change is zero. For a multi-order waveplate whose retardation is several times 2π , one should not therefore expect to see a large phase change. It was shown in ref. 22 that the origin of these effects lies in the geometric phase which dominates the phase change near the singularity.

An experimental observation of a phase jump of this type in an interference experiment was reported by Schmitzer *et al.*²⁴. Independently, the present author reported an observation of such phase jumps, along with the change in the sign of the phase shift and an explicit demonstration of the associated singularity, thus demonstrating the full complexity of the geometric

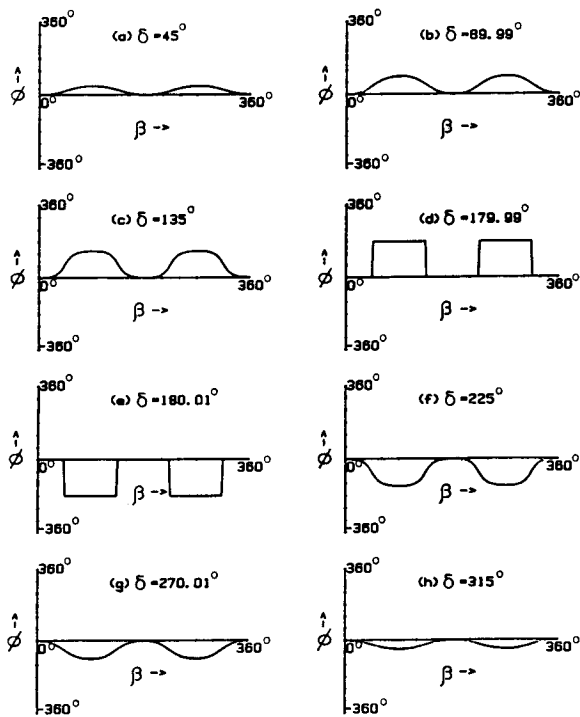

Figure 3. The computed variation of the phase difference between the two beams as a function of the angle of rotation of the δ -plate for a few values of the retardation δ . For $\delta = 0^\circ$ and $\delta = 360^\circ$, the phase change is zero for all β and is not shown. Note the flip in the sign of the phase curve in going from $\delta = 179.99^\circ$ to $\delta = 180.01^\circ$.

phase in a two-state system²⁵. Figure 4 shows the computed (solid line) and the observed (dots) phase shifts in this experiment.

Singularities

There are several branches of physics in which one encounters singular structures. Black holes, strings, etc. are examples in astrophysics. Defects like point defects, line defects and domain walls constitute examples in condensed matter physics and are extensively studied in liquid crystal physics²⁶. Closer to the subject of this paper, singular structures have been studied both theoretically and experimentally in the polarization structure of electromagnetic waves by Hajnal²⁷.

The phase jumps described in the previous section also imply the existence of singularities in the parameter space describing the interference experiment which occur whenever the modulus of the complex amplitude whose phase is being measured goes through zero. The experiments described above provide a very simple and convenient arena for the experimental realization of such singularities through a direct phase measurement. In addition, the isomorphism between the light polarization and the two-state quantum system make it possible to carry the results of such experiments over to quantum mechanics trivially. A typical experiment of this kind consists of a configuration of QWPs and HWPs in one or both arms of an interferometer, the orientation angles of which constitute the parameter

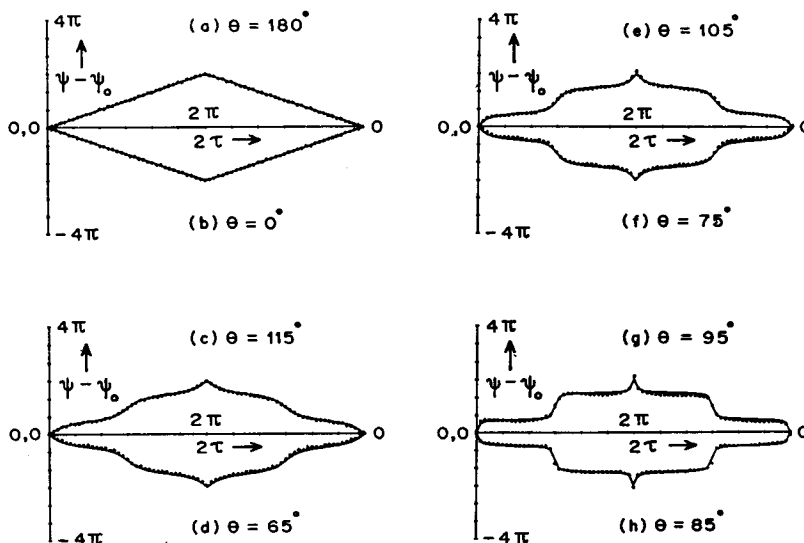

Figure 4. The computed (solid line) and the experimentally observed (dots) phase shifts in an interference experiment as a function of the rotation angle τ of a linear polarizer for different values of a parameter θ that represents the orientation of a QWP. Both interfering beams in this experiment traverse the same path in space, eliminating practically all important sources of error.

space. Two angles are chosen as a parameter space in the experiments reported in ref. 28. The singularities are identified by the condition that the two interfering states become orthogonal at which point the phase difference between the waves must become indeterminate. It is found that the measured phase change equals 2π times the algebraic sum of the strength of the singularities if one follows the phase change continuously along a closed circuit encircling one or more such singularities in the parameter space by means of a sequence of rotations applied the waveplates. A similar, neighbouring circuit not encircling a singularity is found to yield a zero phase change.

4π Spinor symmetry

It is a well-known property of odd half integer spin particles that a rotation about an axis in space through an integral number of 2π applied to such a particle results in a change in the sign of its wavefunction, implying a phase change equal to an odd multiple of π . In particular, for a spin-1/2 particle, one expects a phase change equal in magnitude to π . Such effects have been experimentally demonstrated in neutron interferometer experiments of Rauch *et al.*²⁹ and Werner *et al.*³⁰. These experiments, conducted with unpolarized neutrons, establish the π phase shift up to a sign.

It is also well known³¹ that the quantum mechanics of any two-state system, hence that of the two-state system of polarization of light is isomorphic to that of the spin-1/2 system. It follows therefore that the analogue of the 4π spinor symmetry of the spin-1/2 particles must exist for the light polarization system. Such an analogue was pointed by Byrne³² who suggested an experiment to observe such a phase shift in an interferometer where one rotates the polarization state of a light wave on the PS through 2π by passing it through a fullwave plate and placing a compensating waveplate with zero retardation in the other arm of the interferometer. While possible in principle, such an experiment has the practical difficulty of isolating the resulting phase shift from a possible error in the compensation which could result from a variety of sources. Recently, such an analogue of 4π spinor symmetry in the polarization system has been experimentally demonstrated by us in a series of experiments in which the rotation of the state on the PS can be accomplished about an arbitrarily chosen axis on the PS by means of rotation of a HWP in a suitably chosen combination of QWPs and HWPs³³. The computation of the phase change of an arbitrary spin-1/2 state as a function of rotation on the state sphere using the Pancharatnam's criterion, using a fixed reference state adds another dimension to the problem. One sees that if one chooses the unrotated state as the reference state, while the net phase change for a 2π rotation on the

PS always equals π in magnitude, the phase change is highly nonlinear when the rotating state lies near the equator and changes sign as it crosses the equator. This flip of sign was demonstrated experimentally in ref. 34. More recently, using the technique described in ref. 25, the nonlinear behaviour of the phase change near the equator was also mapped accurately and was found to agree with the calculated curves³⁵. It is hoped that these new effects will soon be seen in neutron experiments sensitive to the sign of the phase shift.

Spinor phase with unpolarized light

The result of a spinor phase experiment with unpolarized neutrons or with unpolarized light may be looked upon as a superposition of two experiments with orthogonal spin or polarization states. Since the two states get phase shifts of the opposite sign under rotation, the resulting variation of intensity in an experiment can be looked upon as a superposition of two fringe patterns moving in the opposite directions. When the maxima of the two coincide, one sees a pattern with high contrast and when the maximum of one coincides with the minimum of the other, one sees a low contrast. This effect was verified by Jayadev Rajagopal in an optics experiment³⁶ using a simple interferometer set-up suggested by Hariharan and Narayana Rao³⁷. When right circularly polarized light was used, we saw a fringe pattern moving towards one side as a function of rotation of an HWP and when left circularly polarized light was used the fringe pattern was seen to move in the opposite direction for the same sense of rotation of the HWP. For unpolarized light a stationary fringe pattern with the fringe contrast modulated as a function of the rotation of the HWP with the expected frequency was seen.

Non-dispersivity of spinor phases

In a medium whose refractive index is independent of wavelength, the phase shifts introduced are inversely proportional to the wavelength. The spinor phases, which are of topological origin, are independent of wavelength. For example, the phase change to be expected for a full rotation of a waveplate in any experiment is equal to $2n\pi$ and this does not change with a small change in the wavelength of the radiation. This property has received attention recently in connection with neutron interferometer experiments of Badurek *et al.*³⁸ where it is shown that the fringe contrast is unaffected even for very large phase shifts equal to several times 2π . The phase shifts observed in the optics spinor experiments also share this property in that practically unlimited magnitude of phase shift can be seen without loss, of fringe contrast as a function of rotation of a waveplate.

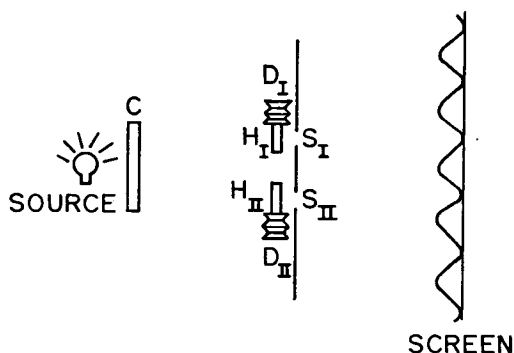

Figure 5. A new version of Einstein's gedanken experiment. Photons from a monochromatic source pass through a circular polarizer C and then have a choice of two classical paths to the screen, i.e. via H_I-S or $H_{II}-S$, where H_I, H_{II} are HWPs and S_I, S_{II} are slits. D_I, D_{II} are angular momentum detectors that can detect any angular momentum transfer to a HWP by a passing circularly polarized photon.

The geometric phase in quantum measurement

The potential of the geometric phase to provide new insights into fundamental problems in physics is nowhere more obvious than in the following example where it turns out that the presence of a geometric phase can be deduced purely from requirements of consistency of quantum mechanics and from the validity of the uncertainty principle. Consider the recently proposed version³⁹ of the famous two-slit gedanken experiment originally debated by Einstein and Bohr⁴⁰ where one seeks to determine the path of the particle, a circularly polarized photon in this case, by detecting the angular momentum $2\hbar$ imparted by the photon to an HWP placed in front of each of the slits (Figure 5). Such angular momentum transfers have in fact been measured experimentally long ago⁴¹. Following Bohr's argument, an unambiguous detection of such an angular momentum transfer would require that the HWP be prepared in nearly an angular momentum eigenstate. The angular momentum-angular position uncertainty relation would then require that the angular orientation of the HWP be completely uncertain. The question that arises is, why should that destroy the interference pattern? Where does the required random phase come from? The answer is, the angular orientation of the HWP is associated with a geometric phase which is precisely of the kind predicted by Pancharatnam and demonstrated in the experiments described earlier in this article. A random orientation of the two HWPs therefore implies a random phase difference between the two interfering paths of the photon and leads to the destruction of the interference pattern. The geometric phase can thus be deduced from the

requirement that an unambiguous determination of the path of the particle in a two-slit experiment must result in the destruction of the interference pattern. Let us recall that this principle has been used earlier by Furry and Ramsey⁴² to show that the Aharonov-Bohm phase, i.e. the phase picked up by a charged particle in going around a closed path that encloses a magnetic flux, can be deduced from similar gedanken experiments.

New theoretical insights

I shall next make a brief mention of some interesting theoretical insights obtained during the course of the geometric phase studies.

Decomposition of mixed evolution of light beams

The interpretation of several geometric phase experiments in optics became simple when it was shown that when a light beam propagates along an optical circuit such that it undergoes changes in its direction of propagation as well as in its polarization state, the mixed evolution can be decomposed into two separate, successive evolutions, one in the polarization space, followed by an evolution in the space of directions in real space²⁰. This simplifies the analysis of polarization behaviour of optical circuits, some examples of which are discussed in ref. 20. The Fermi-Walker transporter shown in Figure 1a played an essential part in arriving at this decomposition scheme.

A method for decomposition of rotations

Another interesting question dealt with in a series of papers starting with a paper by Simon *et al.*⁴³ and ending with ref. 33 was that of the synthesis of gadgets capable of making an arbitrary $SU(2)$ transformation on a polarized light wave by means of sequences of QWPs and HWPs which are easily available optical elements. A convenient and practical sequence for doing this was reported in ref. 33. The method of analysis⁴⁴ used in this paper offers a new approach to problems in which an element of the rotation group needs to be decomposed into a product of elements of a given type. For example, Pancharatnam's elegant result⁴⁵ that the sequence QHQ acts as a variable linear retarder with retardation proportional to the orientation angle of H with respect to the Q's, becomes extremely transparent with this method⁴⁴. In a sense, the geometric phase is used as a tool in this method. Another example of such problems is the turning of cats in free fall or 'zero angular momentum turns'. A simple explanation for such effects using the above method was proposed in ref. 46.

Cyclic state spaces

An attempt to simulate on the polarization system time varying magnetic fields acting on spin-1/2 particles led to a very interesting condition on the parameters of a rotating magnetic field under which all states undergo cyclic evolution⁴⁷. This is the condition under which the unitary time evolution operator governing the evolution becomes equal to ± 1 and this happens when the Larmor frequency in a frame corotating with the magnetic field becomes equal to an integer times the frequency of rotation of the field.

Eigensolutions of $SU(2)$ matrices

A detailed study of the eigensolutions of the $SU(2)$ matrix corresponding to a QHQ retarder first studied by Pancharatnam⁴⁵ reveals some very interesting features involving discontinuous jumps in the location of the principal axis of the resultant linear retarder and in the slope of the eigenvalue vs parameter curves at critical values of the parameters⁴⁸. At these values, the matrix becomes 'degenerate', the condition for which is the same as the condition for the occurrence of cyclic state spaces mentioned earlier.

Concluding remarks

To summarize, while it was adequately emphasized by Berry that the phase is non-integrable, the studies described above bring out the additional fact that phase changes of $2n\pi$ are real, physical and measurable, something that is often ignored. For example, our experiments make it obvious that the difference between $+\pi$ and $-\pi$ or the difference between π and 3π is measurable and that it is unnatural to restrict the value of the phase that is being continuously monitored to lie between 0 and 2π . The need to incorporate this unbounded nature of the phase in theoretical treatments of the phase variable presents a promising programme for the future.

1. Pancharatnam, S., *Proc. Indian Acad. Sci.*, 1956, A44, 247 and *Collected Works of S. Pancharatnam*, Oxford, 1975.
2. Ramachandran, G. N. and Ramaseshan, S., in *Handbuch der Physik* (ed. Flugge, S.), Springer, Berlin, 1961.
3. Nityananda, R., *Pramana*, 1979, 12, 257.
4. Synge, J. L., *Relativity: The General Theory*, North Holland, 1960.
5. Berry, M. V., *Proc. R. Soc. London*, 1984, A392, 45.
6. Ramaseshan, S. and Nityananda, Rajaram, *Curr. Sci.*, 1986, 55, 1225.

7. Berry, M. V., *J. Mod. Opt.*, 1987, 34, 1401.
8. Aharonov, Y. and Anandan, J., *Phys. Rev. Lett.*, 1987, 58, 1593.
9. Samuel, J. and Bhandari, R., *Phys. Rev. Lett.*, 1988, 60, 2339.
10. Hannay, J., *J. Phys.*, 1985, A18, 221.
11. Ghosh, G. and Dutta Roy, B., *Phys. Rev.*, 1988, D37, 1709.
12. Bitter, T. and Dubbers, D., *Phys. Rev. Lett.*, 1987, 59, 251.
13. Wagh, A. G. and Rakhecha, V. C., *Phys. Lett.*, 1992, A170, 71.
14. Tomita, A. and Chiao, R. Y., *Phys. Rev. Lett.*, 1986, 57, 937.
15. Vladimirovsky, V. V., *Dokl. Akad. Nauk. USSR*, 1941, 21, 222.
16. Bhandari, R. and Samuel, J., *Phys. Rev. Lett.*, 1988, 60, 1211.
17. Simon, R., Kimble, H. J. and Sudarshan, E. C. G., *Phys. Rev. Lett.*, 1988, 61, 19.
18. Chyba, T. H., Wang, L. J., Mandel, L. and Simon, R., *Opt. Lett.*, 1988, 13, 562.
19. Tompkin, W. R., Malcuit, M. S., Boyd, R. W. and Chiao, R. Y., *J. Opt. Soc. Am.*, 1990, B7, 230.
20. Bhandari, R., *Phys. Lett.*, 1989, A135, 240.
21. Bhandari, R., *Phys. Lett.*, 1988, A133, 1.
22. Bhandari, R., *Phys. Lett.*, 1991, A157, 221.
23. Bhandari, R., *Spin-1/2 interferometry with light beams*, Proceedings, International Workshop on Lasers and Laser Applications (IWOLA 90), Indore, India, Nov. 12-30, 1990, Wiley Eastern, in press.
24. Schmitzer, H., Klein, S. and Dultz, W., *Phys. Rev. Lett.*, 1993, 71, 1530.
25. Bhandari, R., *Phys. Lett.*, 1993, A180, 21.
26. Chandrashekar, S. and Ranganath, G. S., *Adv. Phys.*, 1986, 5, 507.
27. Hajnal, J. V., *Proc. R. Soc.*, 1987, A414, 433, 447.
28. Bhandari, R., *Phys. Lett.*, 1992, A171, 262, 267.
29. Rauch, H., Zeilinger, A., Badurek, G., Wilfing, A., Bauspiess, W. and Bonse, U., *Phys. Lett.*, 1975, A54, 425.
30. Werner, S. A., Colella, R., Overhauser, A. W. and Eagen, C. F., *Phys. Rev. Lett.*, 1975, 35, 1053.
31. Feynman, R. P., *Lectures on Physics*, Addison Wesley, 1965, vol. II, pp. 10-17.
32. Byrne, J., *Nature*, 1978, 275, 188.
33. Bhandari, R. and Dasgupta, T., *Phys. Lett.*, 1990, A143, 170.
34. Bhandari, R., *Phys. Lett.*, 1993, A180, 15.
35. Bhandari, R., to be published.
36. Bhandari, R. and Rajagopal, Jayadev, unpublished.
37. Hariharan, P. and Narayana Rao, D., 'A simple white light interferometer operating on the Pancharatnam phase', preprint 1993.
38. Badurek, G., Weinfurter, H., Gahler, R., Kollmar, A., Wehinger, S. and Zeilinger, A., *Phys. Rev. Lett.*, 1993, 71, 307.
39. Bhandari, R., *Phys. Rev. Lett.*, 1992, 69, 3720.
40. Bohr, N., in *Albert Einstein Philosopher-Scientist* (ed. Schilpp, P. A.), Library of Living Philosophers, Evanston, 1949, pp. 200-241.
41. Beth, R. A., *Phys. Rev.*, 1936, 50, 115.
42. Furry, W. H. and Ramsey, N. F., *Phys. Rev.*, 1960, 118, 623.
43. Simon, R., Mukunda, N. and Sudarshan, E. C. G., *Pramana*, 1989, 32, 769.
44. Bhandari, R., *Phys. Lett.*, 1989, A138, 469.
45. Pancharatnam, S., *Proc. Indian Acad. Sci.*, 1955, A41, 137.
46. Bhandari, R., *Horizons in Physics* (ed. Nath, N.), Wiley Eastern, vol. II, in press.
47. Bhandari, R., *Physica*, 1991, B175, 111.
48. Bhandari, R. and Love, Gordon D., 'Polarization eigenmodes of a QHQ retarder - Some new features', to appear in *Opt. Comm.*