

<b>RRI-EEG Internal</b>
<b>Technical Report No. : 1</b>
<b>Date : 10/02/2021</b>

## **A Wide-band RF Receiver system for Sky Watch Array Network**

**K.B.Raghavendra Rao<sup>1</sup>, Sandhya<sup>1</sup>, Arasi Sathyamurthy<sup>1</sup>, H.N. Nagaraja<sup>1</sup> and A.A.Deshpande<sup>1</sup>**

**Raman Research Institute, Bangalore – 560080.**

### **ABSTRACT**

The Indian SWAN (Sky Watch Array Network) initiative aims to significantly enhance Indian observing capabilities in radio, and importantly, also to sustainably build & nurture future generations of talented radio astronomers in India to take up the challenges and lead in exciting research in astronomy. The SWAN focus is to design, develop and use a wide-band interferometric array of antenna across different parts of India to facilitate and conduct deep searches & studies of fast and slow transient radio radiation from astronomical sources, also enabling high angular resolution (VLBI) imaging of discrete galactic & extragalactic sources at low radio frequencies. It also facilitates hands-on experience to a large number of undergraduate/postgraduate students through their direct & active participation, starting from the design stage to competitive research using the array network. The proposed competitive network, with nominally 1000 sq. m array area at each location and operation spanning a decade in frequency (50-500 MHz). In view of the above proposal, a broad-band RF receiver system has been built in EEG laboratory and interfaced with the broad-band digital receiver system.

### **1. INTRODUCTION**

Basically there are four RF wide-band receiver chains designed to operate in the frequency range 50MHz – 400MHz having bandwidth of 350MHz which are capable of processing simultaneously four single or two dual polarization RF antenna signals. Each RF chain process the wide-band signal with analogue conditioning and provides two corresponding sub bands for the digitization. So four chains hence provides eight corresponding analog conditioned outputs with prescribed band widths. These eight RF band signals are fed to digital correlator receiver for further cross correlations. This set of four

RF receiver chains are embedded in one wide broad-band receiver system rack, along with 8- input high-speed ADCs and Virtex-6 FPGA based digital back-end receiver.

## 2 Wide-Band RF Receiver System design

To design an low-noise RF front-end receiver system , we require certain primary inputs like frequency Range, sky brightness temperature, antenna efficiency and it’s return loss, optimum total power over the frequency band for ADC digitization and undesired RFI strength situation in the place of astronomical observations. Based on these inputs, the receiver gain, noise figure, dynamic range of the receiver are computed.

### 2.1 Input specifications:

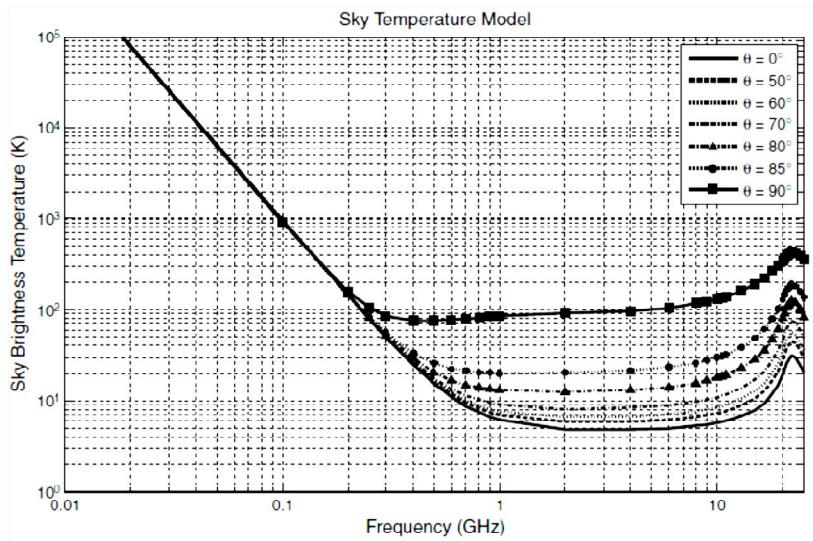
1. A linear, high gain and dynamic range low-noise front-end RF receiver system operating in the frequency range from 50MHz to 350MHz.
2. Since the undesired FM radio band signal highly saturates the amplifiers which limits the dynamic range of the low-noise front-end receiver, the sky observations becomes tedious, hence requirement of 88-108MHz band stop filter in the RF chain
3. Analog conditioning of the wide RF band using filters for deriving the 175MHz Nyquist band limited signals for further digitization and cross correlations using digital back end receiver.
4. The maximum RF input power to the ADC is -10 dBm over the 175MHz nyquist band.

### 2.2 Sky Brightness Temperature Approximation

To compute the total gain of the front-end receiver in the frequency range 50-350MHz, the available power spectral density at the antenna terminals over the specified RF band is to be known apriori. The sky brightness temperature based on the total intensity of full sky Galactic synchrotron emission in the frequency range 50 MHz to 350MHz is computed from the basic synchrotron frequency spectral index equation as follows:

$$\frac{T_1}{T_2} \propto \left[ \frac{f_1}{f_2} \right]^{-2.4} \text{ ----- Eqn 1}$$

## Reference Sky temperature model



To compute the sky temperature over a band of frequencies,  $T_1$  at frequency  $f_1$  needs to be known. This  $T_1$  value is obtained from the plot Sky temperature model in the frequency range of the SKA given in the original article “Analysis of sky contributions to system temperature for low frequency SKA aperture array geometries By N. Razavi-Ghods · E. de Lera Acedo · A. El-Makadema · P. Alexander · A. Brown”.

It can be observed from the reference sky model, that the sky temperature is in the decreasing order from 6000K to 30K in the frequency range from 50MHz to 400MHz. So the noise figure of the low-noise amplifier has to be as low as possible from 200MHz onwards with reasonably high gain, so that higher SNR can be achieved.

The total  $T_{sky}$  over the bandwidth 350MHz is computed using integration of area under the curve with spectral resolution of 1MHz and it is around 7500K. Total power spectral density ‘S’ in the frequency range 50MHz to 400MHz is obtained using the below equation

$$S = 10 \cdot \log_{10} (\text{Antenna Gain} * T_{sky} * 10^6 * 1000)$$

At present the antenna array is assumed to be MWA Bow-tie dipole antenna based tile. From the MWA documents as a reference, the tile antenna gain over aperture area of  $12\text{m}^2$  is around 7dB.

From the above computations, it’s the total available antenna temperature in terms of power corresponding to the sky brightness temperature in the frequency range 50MHz to 350MHz is around

-100dBm. The required total power over the 350MHz band for the proper digitization of the ADC is typically around -10dBm.

From the above inputs, the total gain of the front-end receiver is computed as follows

$$10^{(-100\text{dBm}/10)} + 10^{(-10\text{dBm}/10)} = 90\text{dB}$$

### **2.3 RF Band Analog Conditioning**

To implement a band limited wide band RF front-end receiver in the frequency range from 50MHz to 350MHz, a band-pass filter with 3dB corner frequencies at 45MHz and 350MHz has been implemented with high attenuation of around 30 dB – 40dB in the stop band frequencies above 400MHz to avoid aliasing effects in the further stages. Also to avoid the saturation and non-linearity of the low-noise amplifier due to strong FM band frequencies, a band-stop filter has been included which rejects the FM band frequencies in the frequency range from 91-108MHz upto 40dB. A high gain amplifier having a typical gain of 70dB with 30dB variability is implemented. Finally the RF band is split into two sub-bands having bandwidth of 175MHz for ADC digitization.

## **3. 50MHz – 350MHz Wide -band RF Receiver System Implementation**

The block diagram of Broad-band RF receiver system is as shown in the figure 1. Each receiver chain consists of a high dynamic range integrated low-noise amplifier, and a 4 stage high gain amplifier module having gain of 90dB, operates in the 50-500MHz frequency range. To split the 350MHz bandwidth into two sub-bands and for proper digitization, an analog band shaping section has been incorporated, containing a set of low-pass and a band-pass analog filters. These filters acts as anti-aliasing filters for further sampling of the broad-band signal. Each of these processing blocks are explained in detail in the further sections.

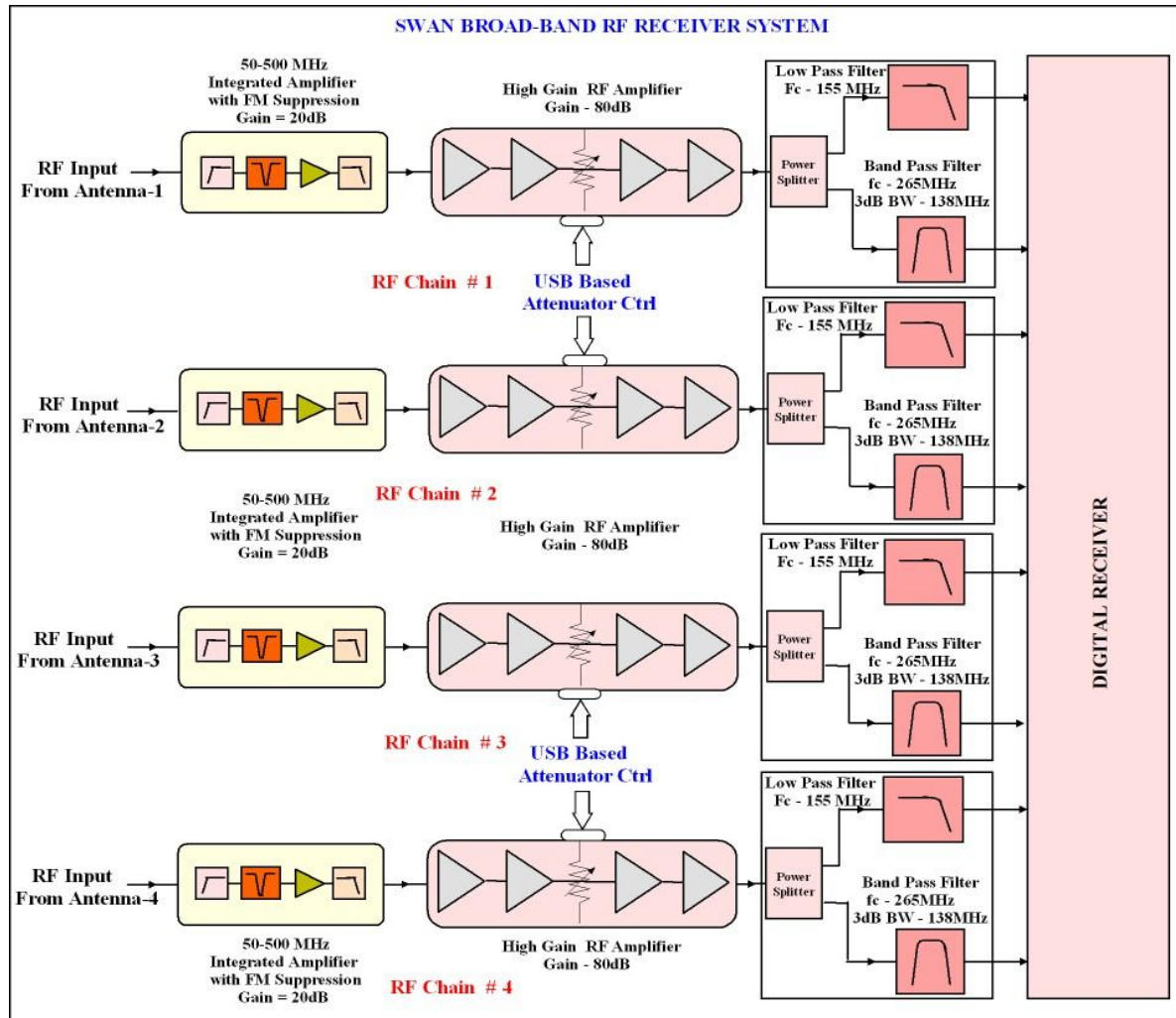
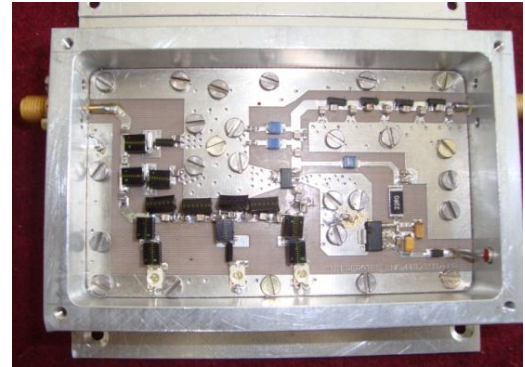
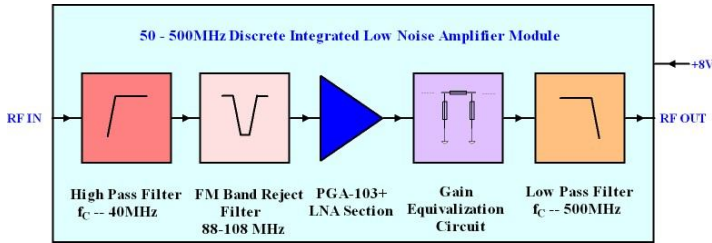


Figure 1. Block Diagram of Broad-band Receiver System

### 3.1 Integrated Low-Noise Amplifier

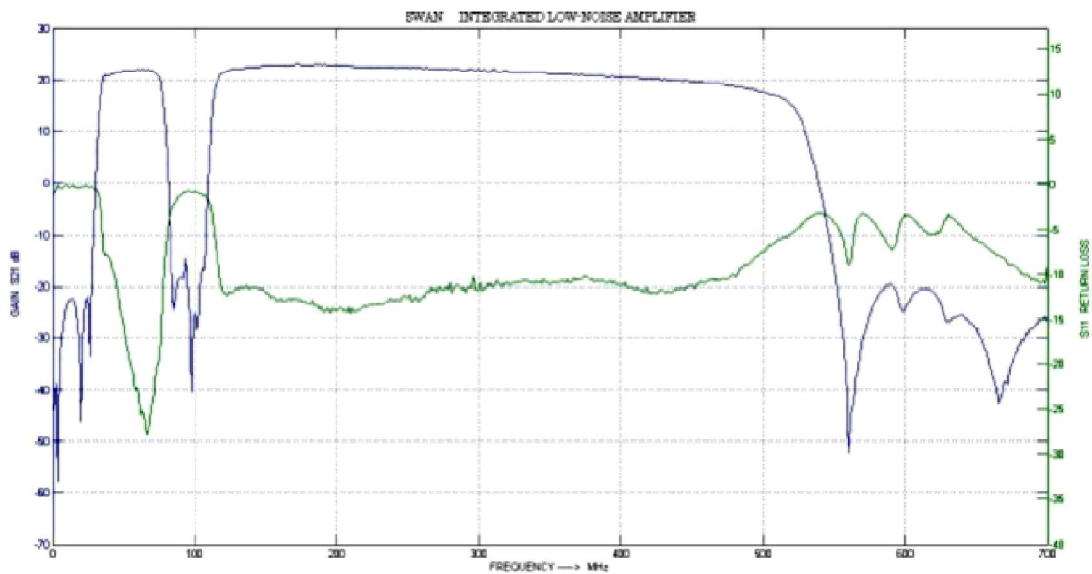
The very first element in the broad-band RF receiver system is the integrated low-noise amplifier which is designed to operate in the decade frequency range 50MHz to 500MHz. The input of this amplifier is fed with the antenna array output. The low-noise amplifier is implemented using Mini-circuit based PGA-103+ high dynamic range monolithic amplifier. It is an advanced wideband high gain amplifier offering low noise figure ranging from 0.5dB to 1.4dB from 50MHz to 4GHz frequency range. In our application, the frequency band is limited to 500MHz designed to have reasonable gain of 20dB with gain flatness of  $\pm 1.5$ dB in the specified frequency range. A gain slope equalization circuit has been employed to minimize the slope in the band of interest as shown in the figure 2.



**Figure 2. Block diagram of Integrated LNA**

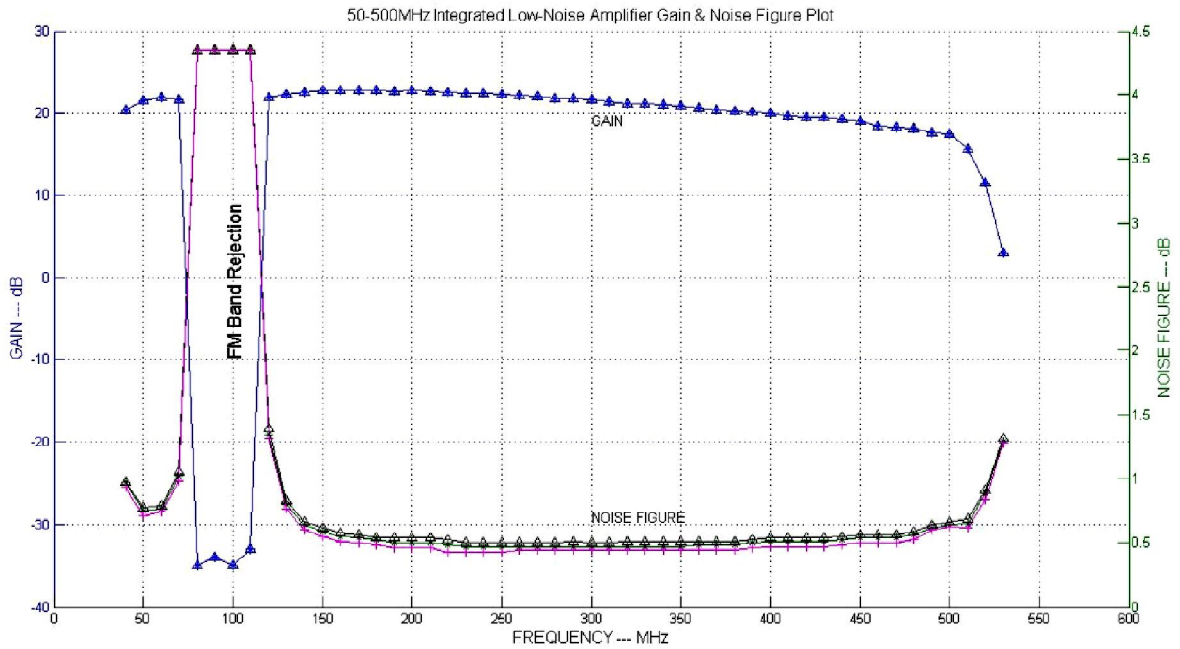
**Photograph of Integrated LNA**

In addition, a band- pass filter is also implemented as a combination of high- pass filter and a low- pass filter in the chain as band shaping section to avoid the aliasing effects in further digitization stages. The low loss high-pass filter with sharp high cutoff at 40MHz as the first element and a sharp roll-off low- pass filter with cut-off at 500MHz as the final element. An FM band-stop filter followed by the high pass filter has been accommodated to reject the strong FM radio signals in the frequency range 88-108MHz. The attenuation in the rejection band is around 40 dB and the insertion loss in the pass band is optimized to be very low. Since the high- pass filter and the FM band-stop filters are the initial elements, these filters are designed to have as low insertion loss as possible in the pass band to minimise the over all noise figure of the amplifier. The gain equalization section has been implemented and optimized to have over all reasonably high dynamic range throughout the frequency range of operation.

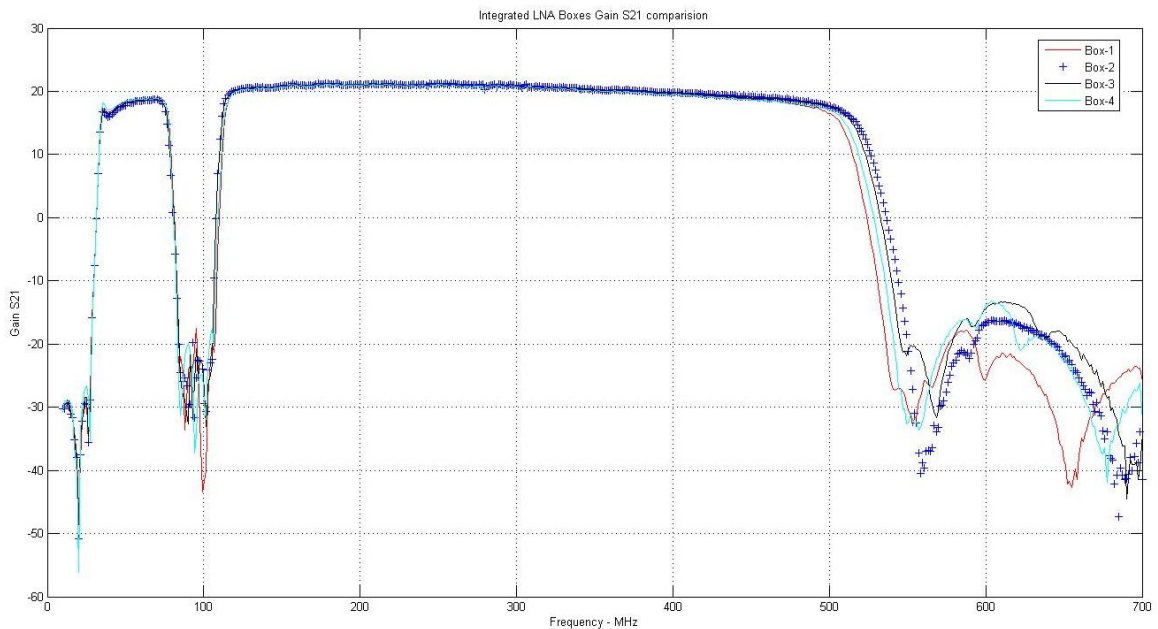


**Figure 3. Measured Frequency Response of the Integrated Low-Noise amplifier**

The over all measured gain (S21) and return loss (S11) response of the amplifier over the designed frequency range 50-500MHz are as shown in the figure 3.



**Figure 4. Measured Gain and Noise temperature plot of the Integrated Low-Noise amplifier**



**Figure 5. Measured S21 plot of all the four integrated amplifiers**

For the integrated low-noise amplifier, the total noise figure is the equivalent noise at its input which is the cascade effect of the high-pass filter, band stop filter, low-noise amplifier and then the low-pass filter. Even though the lossy filters are preceding the low-noise amplifier PGA-103, the insertion losses in the pass band are optimized to be very low so that the overall noise figure of the integrated low noise amplifier is least affected by them.

The noise temperature T of the amplifier in K are measured in the frequency range 50-500MHz at room temperature and at other extreme temperatures like 0°, 50° is as shown in the figure 4.

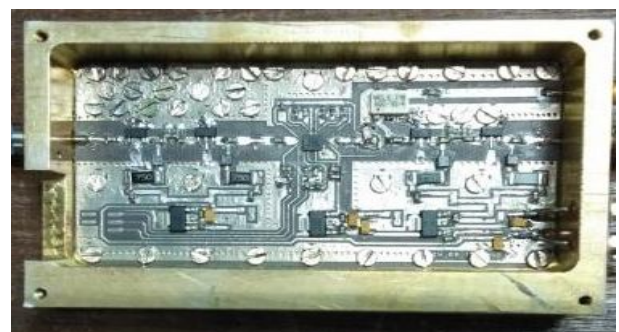
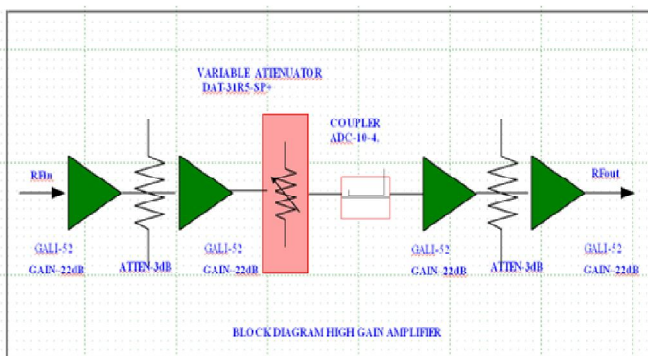
The noise figure can be calculated using the following relationship

$$\text{Noise factor NF} = 10 \log \left( 1 + \frac{T}{290} \right) \text{ dB}$$

It can be observed from the plot that, the noise figure varies from 0.7 to 0.9 dB and 0.5 to 0.6dB in the frequency ranges from 50 to 70MHz and 120 to 350MHz respectively.

**\*\*\*\*For detailed information about the Integrated amplifier, the EEG technical report No:3 ” 50-500MHz Integrated Amplifier with FM band Rejection” can be referred.**

### 3.2 High Gain Amplifier

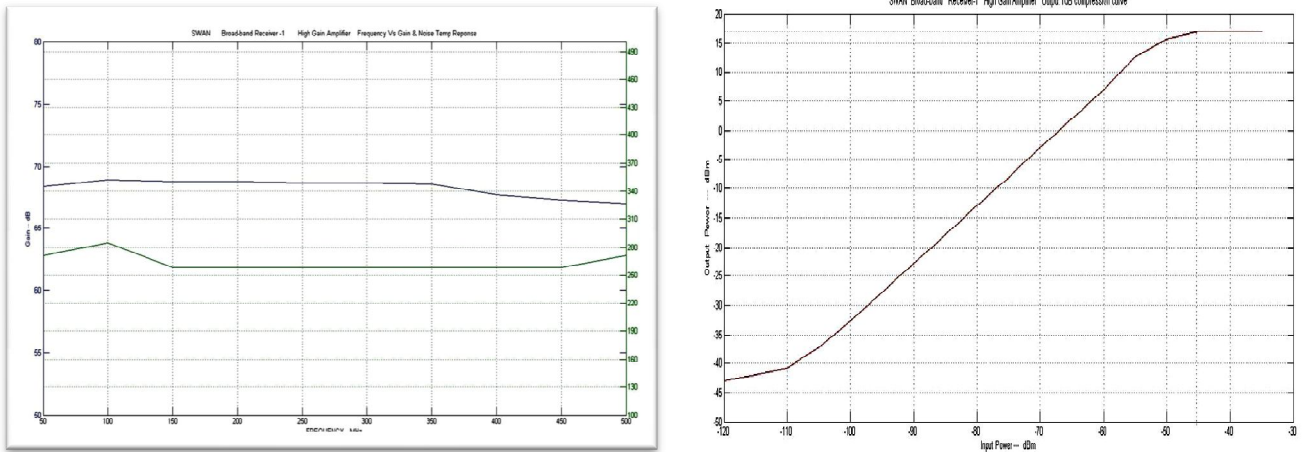


**Figure 6. High Gain Amplifier Module**

In the high gain amplifier section, the RF signal is amplified before it is fed to the band shaping filters. The total gain provided by the amplifier block is about 85 dB, by cascading four GALI-52 MMIC amplifiers power as shown in the schematic diagram. However, the gain can be varied over the range 85dB to 55dB using 30dB variable attenuator (DAT31R5-SP+). The attenuation value can be changed



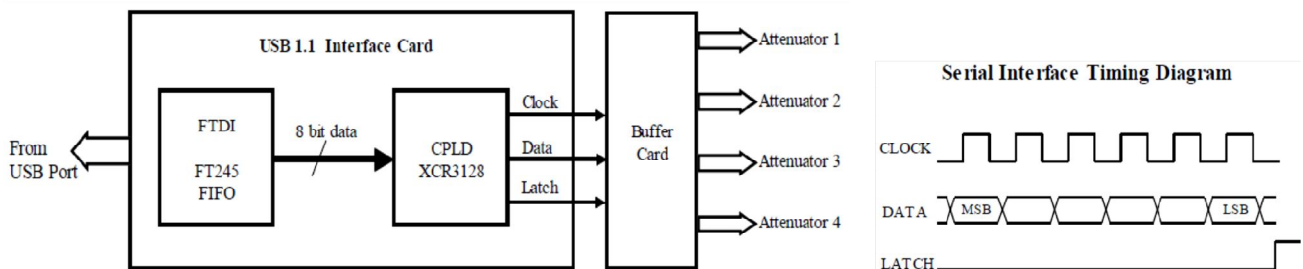
using a USB 1.1 interface board. A 10 dB coupler (ADC-10-4) is used in this section to monitor the RF spectrum. The overall RF gain has droop of about 3 dB in the 50 MHz to 1 GHz range.



**Figure 7. Gain and dynamic range plot of High gain amplifier**

The DAT-31R5-SP+ is a 50 ohm RF digital step attenuator that offers an attenuation range up to 31.5 dB in 0.5dB steps, operating on a single +3 volt supply. The digital control is a 6-bit serial interface used to select the desired attenuation state. The digital serial control for setting the attenuation is done through the Computer Universal Serial Bus(USB) port. A standard USB 1.1 card is interfaced to CPLD XCR3128 through a FTDI USB first in, first out (FIFO) chip. The FT245R is a USB to parallel FIFO interface. The Parallel data from the FTDI enters the CPLD and is decoded to generate three control signals required for the attenuator namely Data, Clock and Latch enable. The Data and the Clock inputs are serially transmitted as shown in figure 12 to the serial interface of the attenuator. The Latch enable is an active high signal.

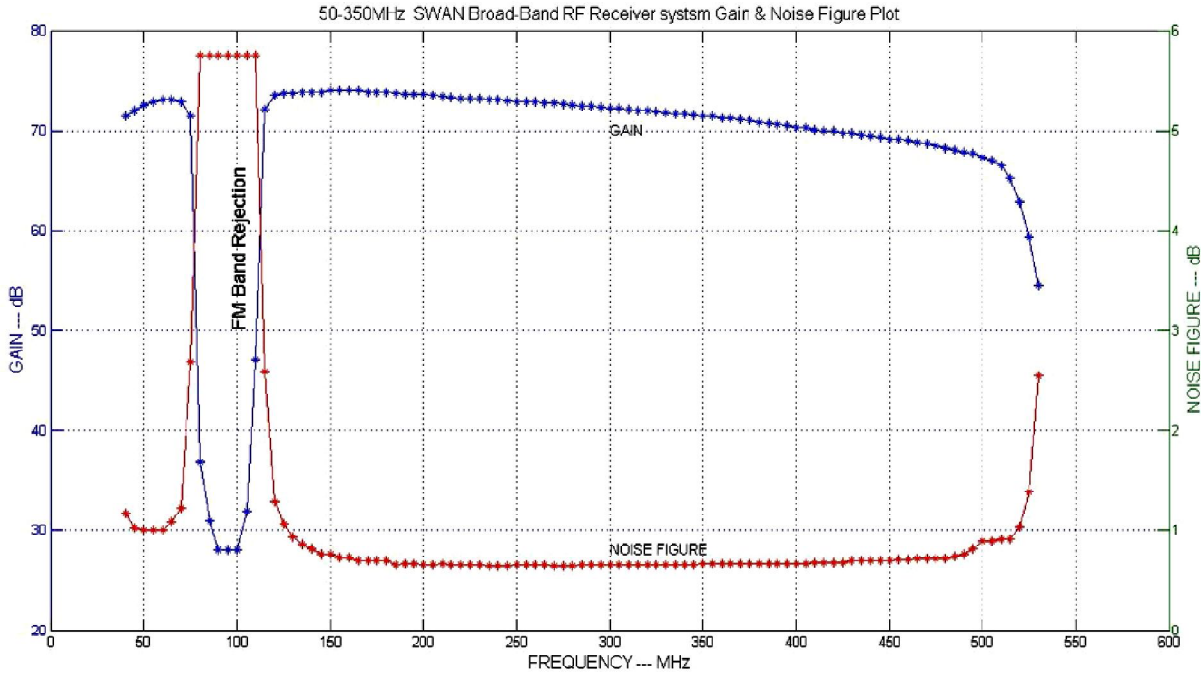
**MSB LSB CLOCK DATA LATCH Serial Interface Timing Diagram**



**Figure 8. Block diagram of USB interface card**

**Timing diagram of the attenuator controls**

Figure 8 shows the block diagram of the attenuator control through USB interface card. The attenuator 1, 2, 3 and 4 corresponds to the two signal channels of the RF and IF signals to be attenuated.



**Figure 9. Frequency response and noise figure of the cascade effect of Integrated amplifier and the High gain amplifier with default attenuation of 16dB**

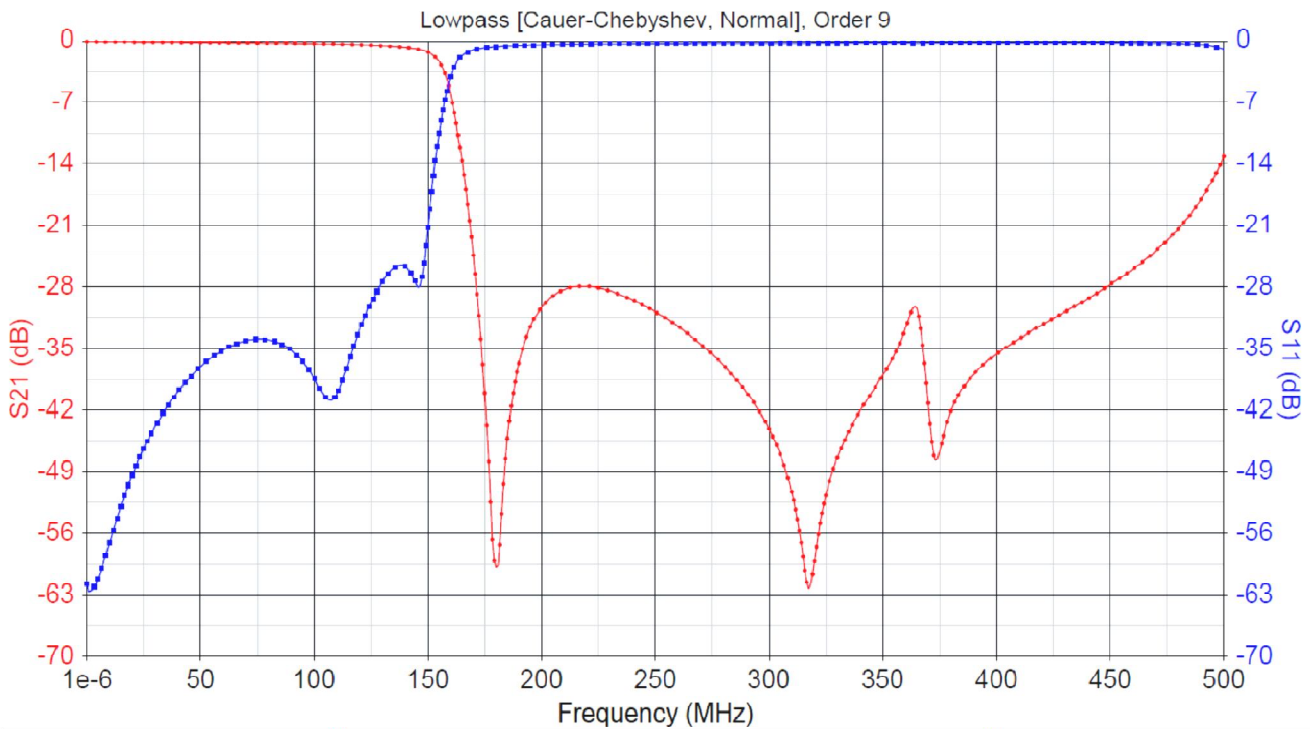
### 3.3 Band shaping Filters

Due to increase in cross-correlations between RF bands and its data handling capacity within the FPGA of the digital receiver, the maximum processing bandwidth has been arrived to less than 350MHz. The corresponding required sampling frequency has been chosen as 350MHz. To avoid aliasing, the required nyquist band for base band sampling must be less than or equal to 175MHz, and rest of the RF bandwidth for band sampling must be within 175MHz with good rejection of at least 30dB to 35dB at 350MHz. To meet the above digitization scheme, the amplified RF band has been split into two sub-bands viz low-pass 0-155MHz and band-pass 188MHz-324MHz centered at ~260MHz using a power splitter, as shown in figure 1.

To achieve **the first sub-band digitization**, a chebyshev type 9<sup>th</sup> order **microwave Low-pass filter** has been designed with -3dB pass-band frequency cut-off at 155MHz. Stepped impedance with open stub resonators design type are used to obtain reasonably good cut-off at 155MHz and stop-band attenuation of nearly 40dB at 175MHz.

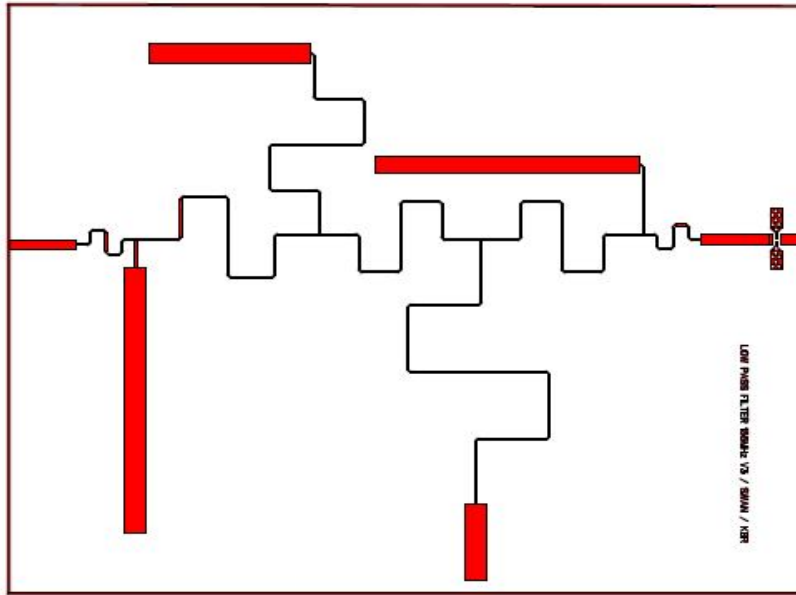
### Low-Pass Filter :

A chebyshev type 9<sup>th</sup> order **microwave Low-pass filter** has been designed with -3dB passband frequency cut-off at 155MHz. The required stop-band rejection at 175MHz is around -40dB. The microstrip based design has been optimized and simulated using economy FR4 glass epoxy substrate (PCB) having di-electric constant of 4.5 and height of the laminate is 1.6mm. The achieved insertion loss in the pass-band is around <1.5dB with return loss of <-13dB.



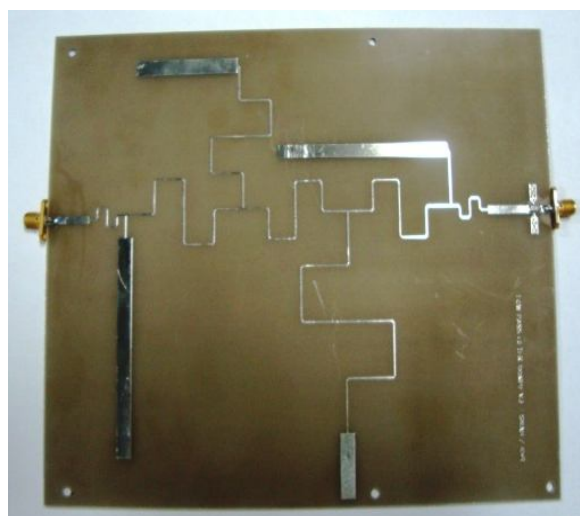
**Figure 10. Low-pass filter S21 and S11 simulated response**

Stepped impedance with open stub resonators are used to obtain reasonably good cut-off at 155MHz and stop-band attenuation of nearly 40dB at 175MHz. To reduce the size of the filter, fractal structure reduction technique has been implemented in the design. The designed and simulated S21 and S11 response are shown in the figure 10. The implemented and fabricated microstrip PCB layout is shown in the figure 11 .



**Figure 11. PCB layout of Microstrip Low-pass filter implementation on FR4 glass epoxy Er – 4.**

To reduce the size of the filter, **fractal structure reduction technique has been implemented** in the design. The designed S21 and S11 response are shown below in the figure. The required stop-band rejection at 175MHz is around -40dB. The microstrip based design has been optimized and simulated using economy FR4 glass epoxy substrate (PCB) having di-electric constant of 4.5 and height of the laminate is 1.6mm. The achieved insertion loss in the pass-band is around <1.5dB with return loss of less than -13dB. The microstrip PCB layout is shown in the figure 11 and its implementation photograph as shown in figure 12.



**Figure 12 photograph of Microstrip Low-pass filter fc- 155MHz**

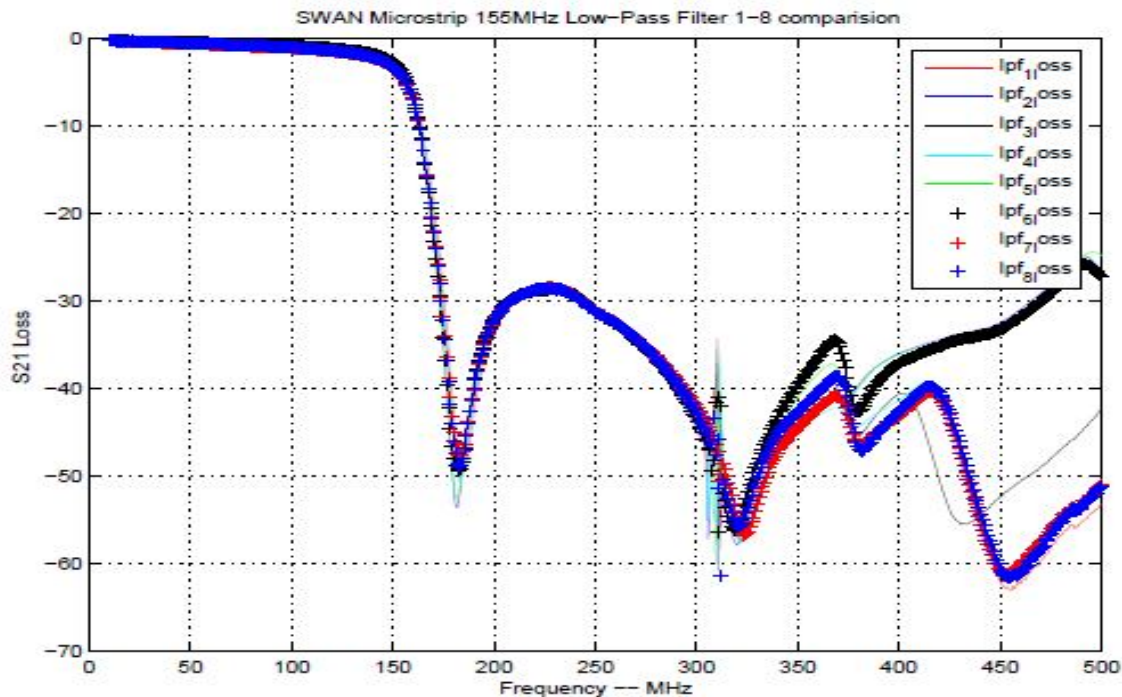


**Figure 13. Measured S21 and S11 Response plot of the microstrip low-pass filter**

The insertion loss is maintained at  $< -1.5\text{dB}$  and the return loss is about  $< -15\text{dB}$  throughout the pass band frequencies as shown in the figure 13.

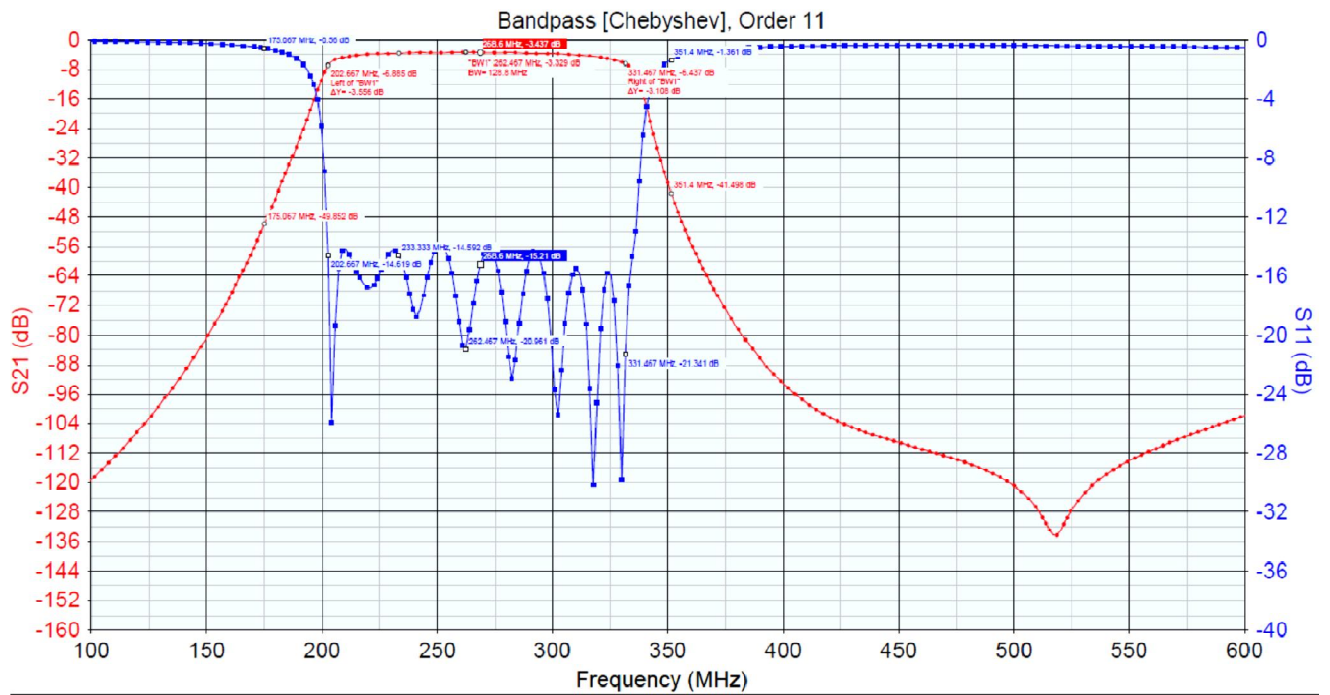
The microstrip low-pass filter was tested and its measured S21 and S11 response are shown in the figure 2b. From the plot, it can be observed that the achieved  $-3\text{dB}$  cut-off frequency is at  $155\text{MHz}$  and the stop band attenuation in the frequency interval from  $175\text{MHz}$  and  $350\text{MHz}$  is approximately around  $30\text{dB}$ .

The comparison S21 plots of implemented eight microstrip low-pass filters is shown in figure 14.



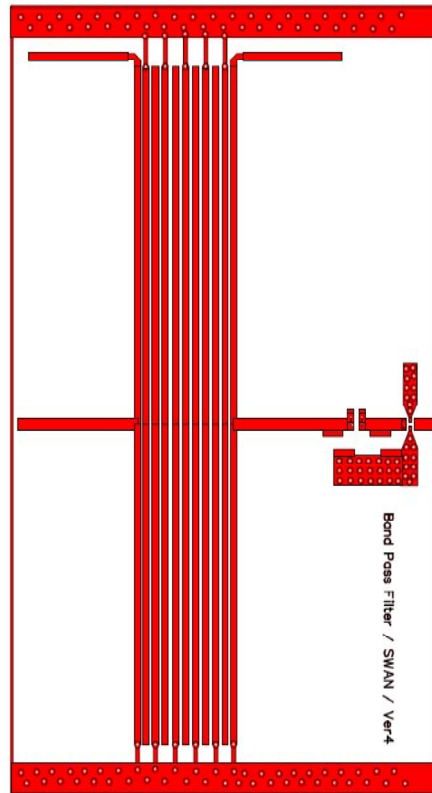
**Figure 14. Comparison of the frequency response of 8 microstrip low-pass filters.**

- To digitize the second sub-band, a chebyshev type 11<sup>th</sup> order microwave band-pass filter has been designed. The design specifications are as follows with center freq 260MHz with -3dB band width is 128MHz. The microstrip based design has been optimized and simulated using economy FR4 glass epoxy substrate (PCB) having di-electric constant of 4.5 and height of the laminate is 1.6mm The simulated insertion loss in the pass-band is around <5dB with return loss of <-15dB. The maximum bandwidth obtained is around 128MHz with rejection at 175 MHz and 350MHz are around 30 - 40dB. The droop in the pass band is 4-6dB. An LC based band equalization circuit has been incorporated in the simulation to compensate the droop in the pass-band. The achieved reduction in droop after tuning is around 2 to 3 dB. The microstrip PCB layout and the simulated S21 and S11 response are shown in the figure 15 below.

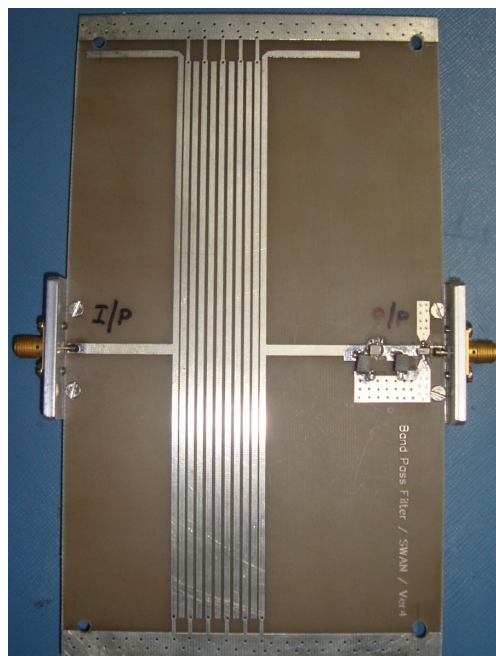


**Figure 15. Simulated S11 and S21 response of the microstrip band-pass filter**

The band-pass filter was designed in such a way that the rejection at 175MHz and 350MHz frequencies are around 35dB. The filter was practically tuned and tested and the achieved bandwidth is around 128MHz. The attenuation in the stop-band frequencies are around 25dB and 38dB at 175MHz and 350MHz frequencies respectively. The microstrip PCB layout is shown in the figure 16 and it's implementation as shown in photograph figure 17. The measured frequency response of the band-pass filter is as shown below in figure 18.



**Figure 16. PCB layout of Microstrip Band Pass Filter,  $f_0$  – 260MHz, BandWidth-128MHz**



**Figure 17 Photograph of Microstrip Band-pass filter**





Figure 18. Measured S21, S11 Response of the Microstrip Band-pass filter

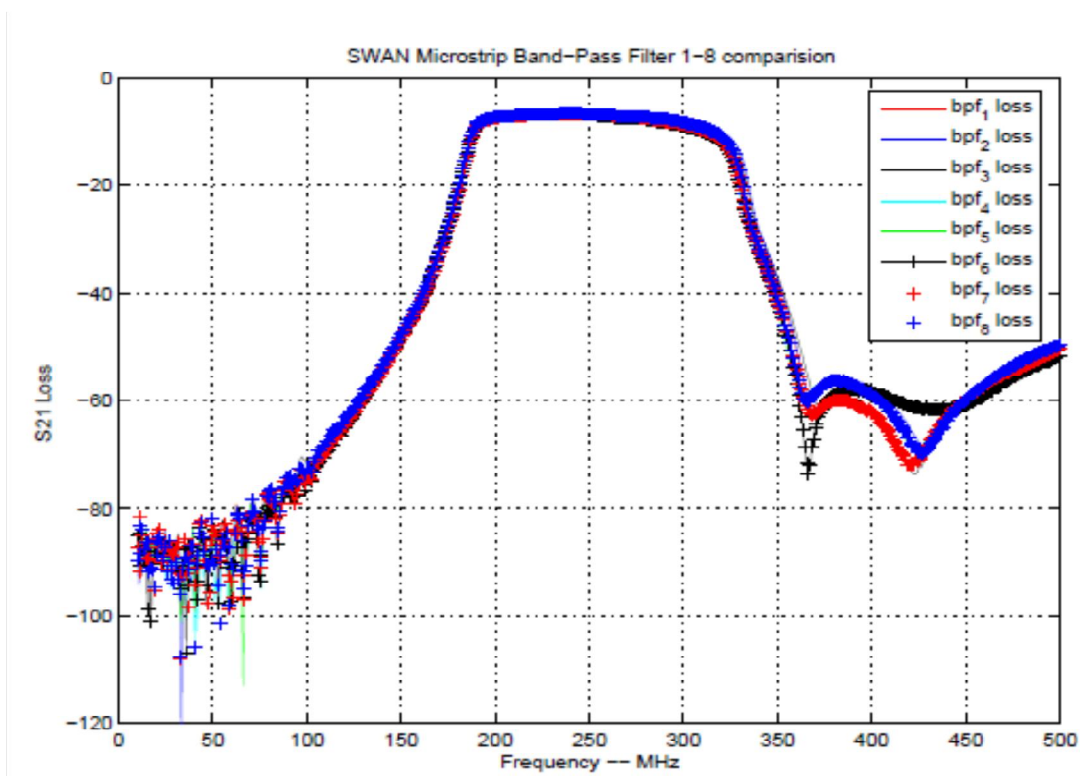
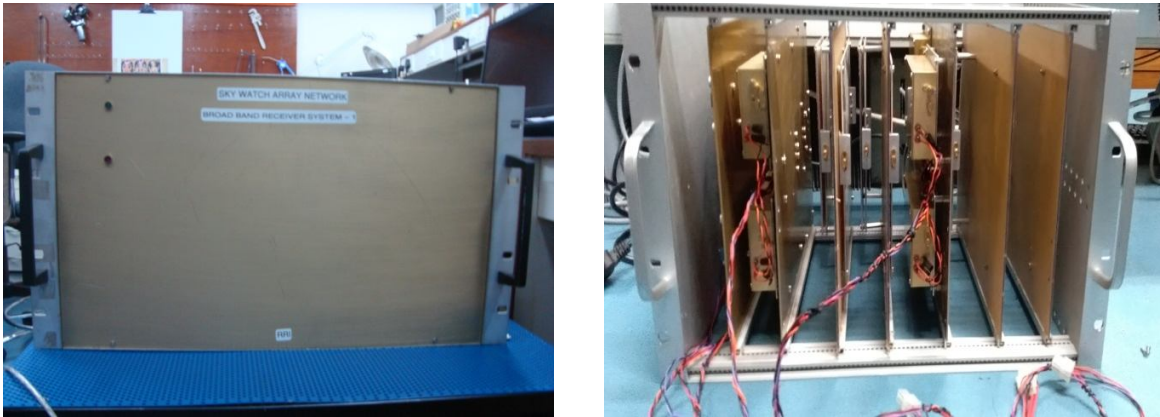


Figure 19. Comparison of the frequency response of 8 microstrip band-pass filters.

#### 4. Implemented SWAN Broad-band Receiver system

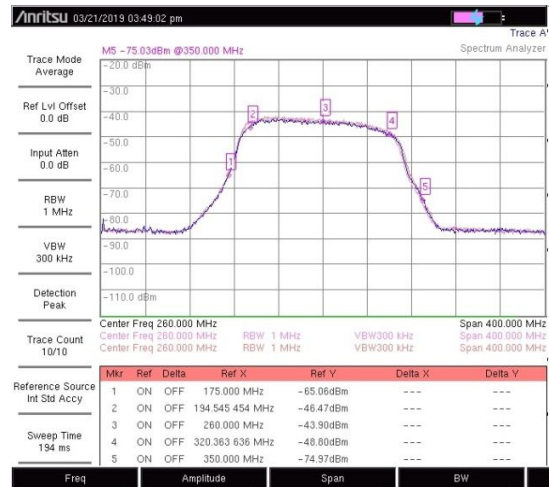
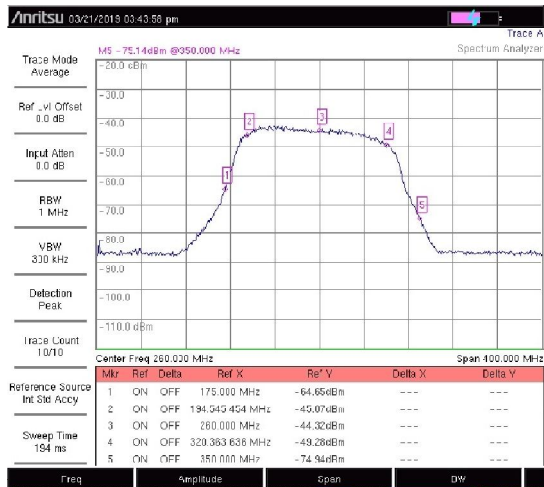


**Figure 20** SWAN Broad-band RF receiver system photograph

- The above figure 20 shows the implemented 50MHz-350MHz SWAN broad-band RF receiver system which has four identical RF processing chains. As described in detail w.r.t the block diagram in figure 1, each RF chain produces corresponding 2 distinct RF sub-bands. The first sub-band frequency ranging from 40MHz to 175MHz, where as the second one covers subsequent 128MHz bandwidth i.e., from 188MHz to 314MHz. Like wise totally 8 sub-bands outputs are available corresponding to 4 RF chains from the receiver system for digital cross correlations as shown in the above photograph. The individual band shape of RF spectrums along with rest of all spectrums overlapped are as shown below in the figure 21a & 21b.



**Figure 21a.** RF power spectrum of the first sub-band from 40MHz – 175MHz



**Figure 21b. RF power spectrum of the Second sub-band from 188 MHz – 314 MHz**

- Each RF chain has initial low noise integrated amplifier with FM band suppression from 91 MHz-107 MHz, and a high-gain module for further amplification to meet the RF power requirement of the ADC in the digital receiver. Each high gain module has 4 stages of RF amplifier with a variable attenuator embedded in between 2<sup>nd</sup> and 3<sup>rd</sup> stages, the value can vary from 0-31.5 dB attenuation value. The total gain in the RF chain is about 70 - 100 dB with 30 dB variability. The RF power within each sub-band can be adjusted by varying the variable attenuator, the value of which can be programmed using a USB based serial to parallel data control card. Most of the integrated amplifiers were retuned critically in the FM notch filter section to get the proper band shape.
- The minimum required RF total power by the ADC is around -23 dBm for the proper digitization. In view of this the amplified signal by the RF chain is power split and attenuated appropriately before connecting to the respective filters, so that the optimal level requirement of the RF power by the ADC is justified.
- Dynamic Range of the RF receiver system were measured by connecting a wide band noise source (10 MHz – 500 MHz) to the RF input of the receiver system. By varying the attenuation value of the variable attenuator, the RF input – output linearity test was conducted. The linearity region (Dynamic range above the minimum pedestal level) obtained from this experiment for 500 MHz bandwidth was around 25 dB.



## **5. Conclusions**

This technical report describes the development and implementation of a low-noise wide band RF front-end receiver in the frequency range 50-350MHz for radio sky observations. The front-end receiver integrates a high dynamic range low-noise integrated amplifier having gain of 20dB and noise figure of 0.6 to 1.1dB, a high gain 4 stage RF amplifier provides signal amplification upto 60 to 90dB to ensure the sufficient RF band power for digitization and analog conditioning block to split the 350 MHz wide band into two sub-bands having bandwidth of each 175MHz. The integrated amplifier ensures the initial level of low-noise amplification of radio astronomical signal upto 20dB and band shaping along with the suppression of undesired strong FM radio interference signal. The analog conditioning low-pass and band-pass filters are designed and implemented using microstrip based distributed element filters. The overall wide-band 50MHz-350MHz RF receiver system was interfaced with the broad-band digital back end receiver and laboratory tests are under progress.

### **Acknowledgements**

We wish to express our sincere thanks to Srivani K.S and Kamini. P.A for involvement in providing valuable suggestions at various stages during this work

Many thanks to Ibrahim and group in the basement workshop for making amplifier and receiver 6U sub-rack chasis.