



US 20090002300A1

(19) **United States**

(12) **Patent Application Publication**
Ruckmongathan

(10) **Pub. No.: US 2009/0002300 A1**

(43) **Pub. Date: Jan. 1, 2009**

(54) **SYSTEM AND METHOD TO DRIVE DISPLAY MATRIX**

(22) Filed: **Jun. 29, 2007**

Publication Classification

(75) Inventor: **T.N. Ruckmongathan, Bangalore (IN)**

(51) **Int. Cl. G09G 3/36 (2006.01)**

(52) **U.S. Cl. 345/89; 345/100; 345/87**

Correspondence Address:
TOWNSEND AND TOWNSEND AND CREW, LLP
TWO EMBARCADERO CENTER, EIGHTH FLOOR
SAN FRANCISCO, CA 94111-3834 (US)

(57) **ABSTRACT**

A system and method to drive display matrix, comprising: a voltage level generator to provide predetermined voltages, a row voltage selector to select a group of voltages from the voltage level generator depending on select vector to drive row drivers, a column voltage selector to select a group of voltages from the voltage level generator depending on data vector to drive column drivers, and a controller to generate control signals to scan the display as dictated by addressing technique.

(73) Assignee: **Raman Research Institute, Bangalore (IN)**

(21) Appl. No.: **11/824,472**

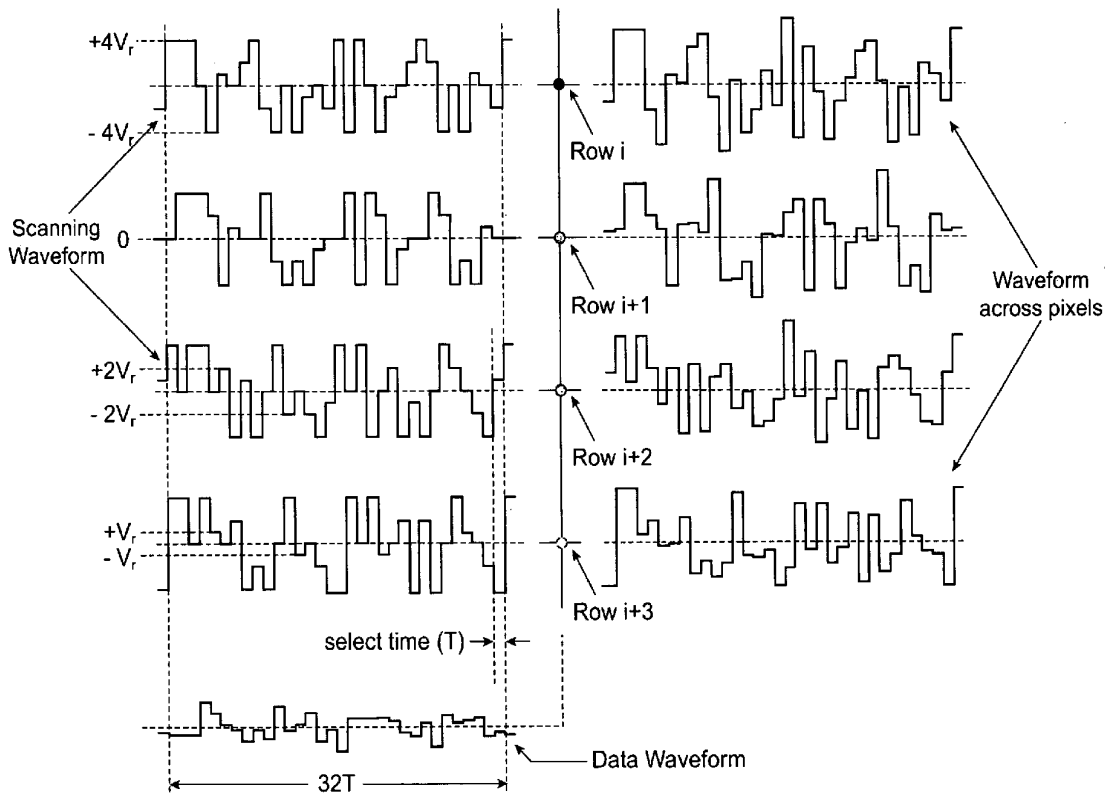

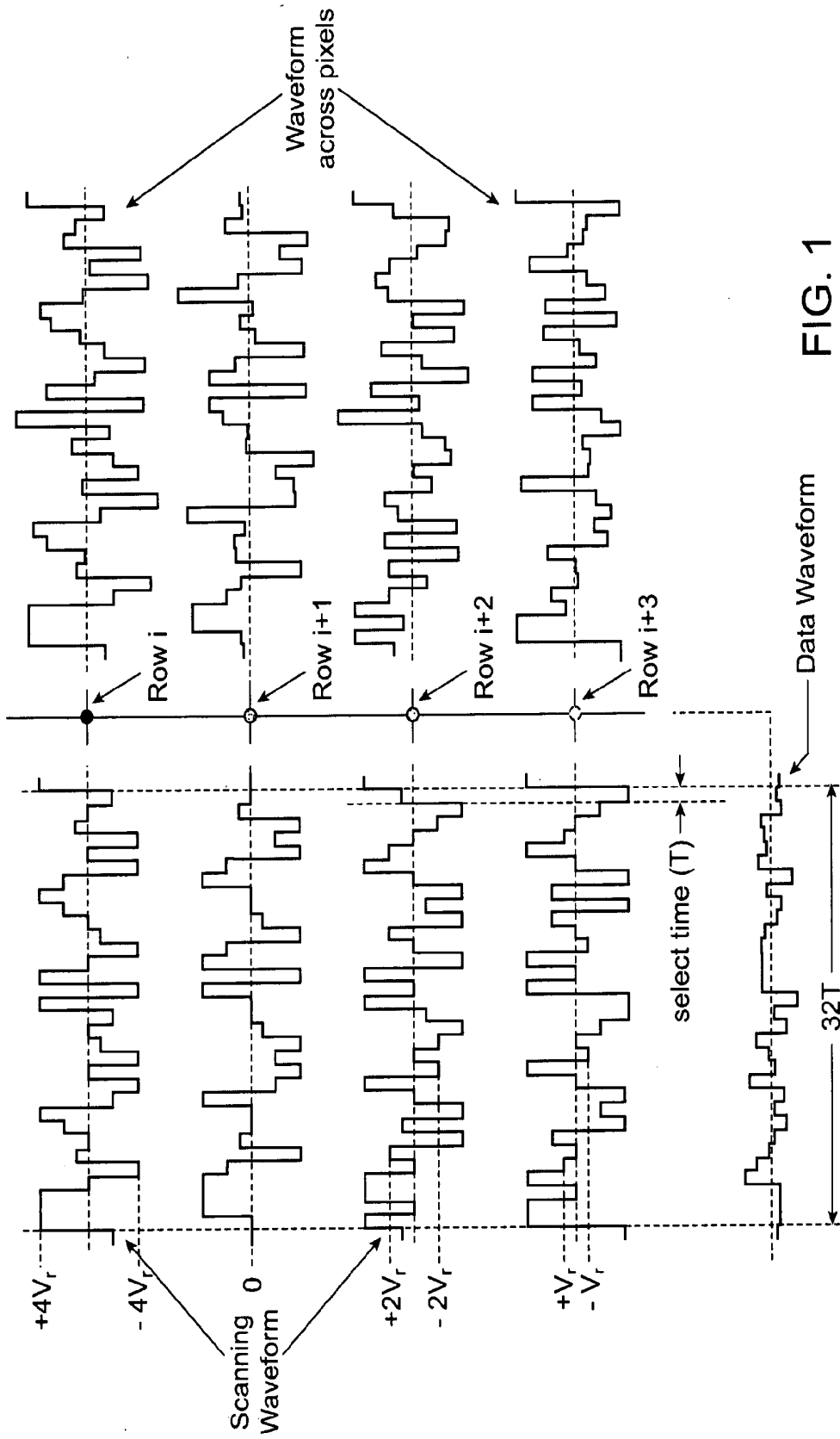

FIG. 1

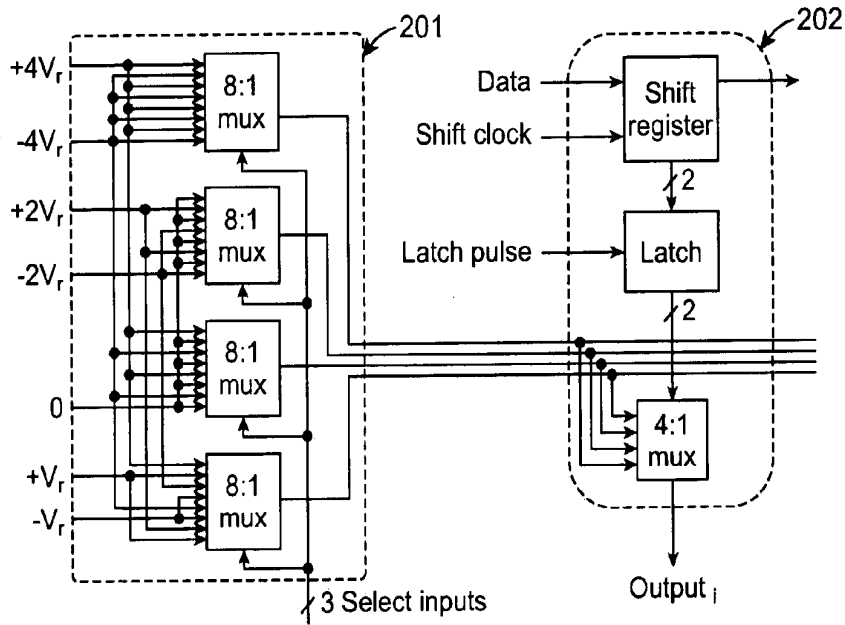

FIG. 2

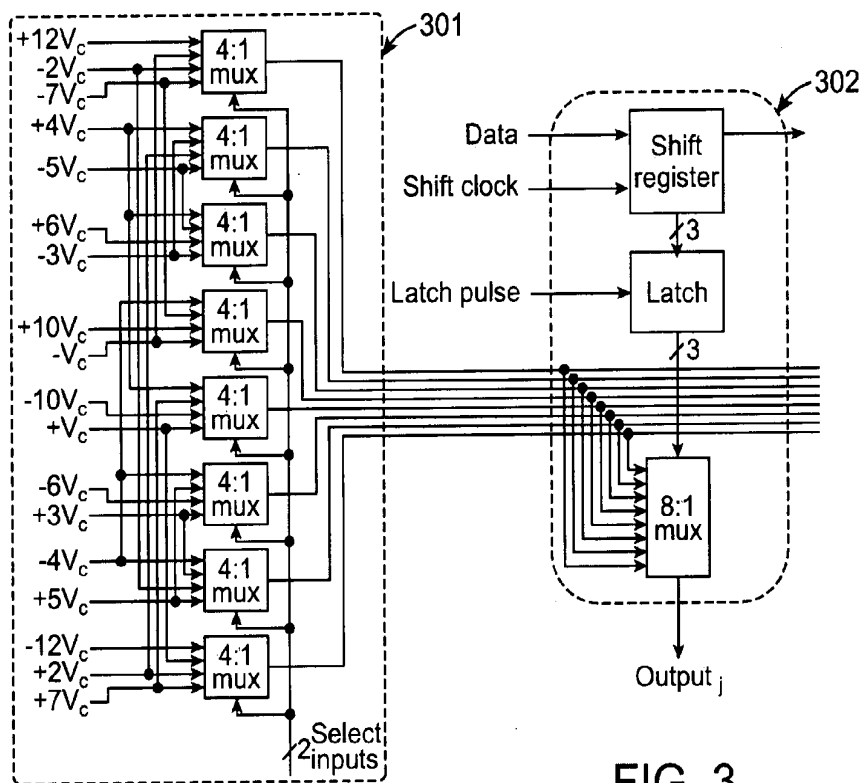

FIG. 3

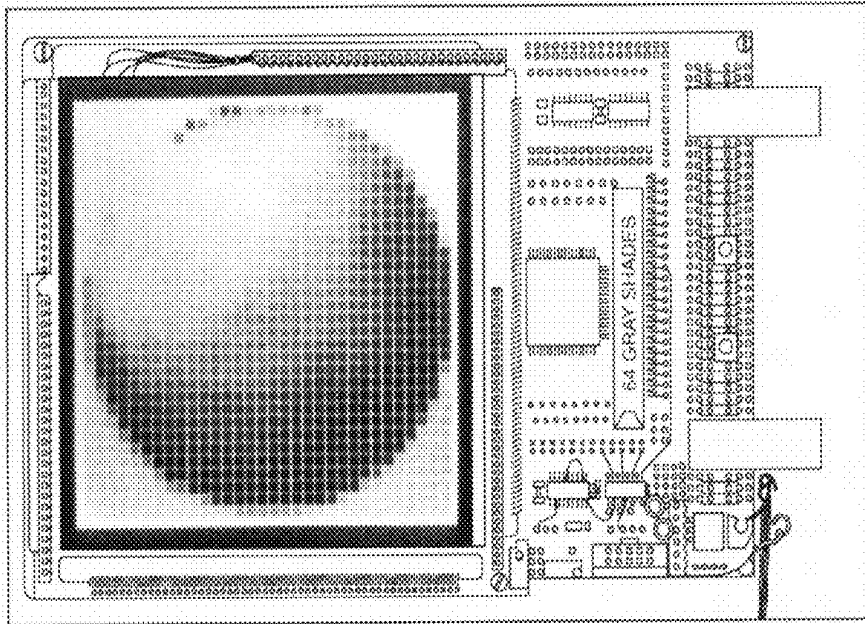

FIG. 4(b)

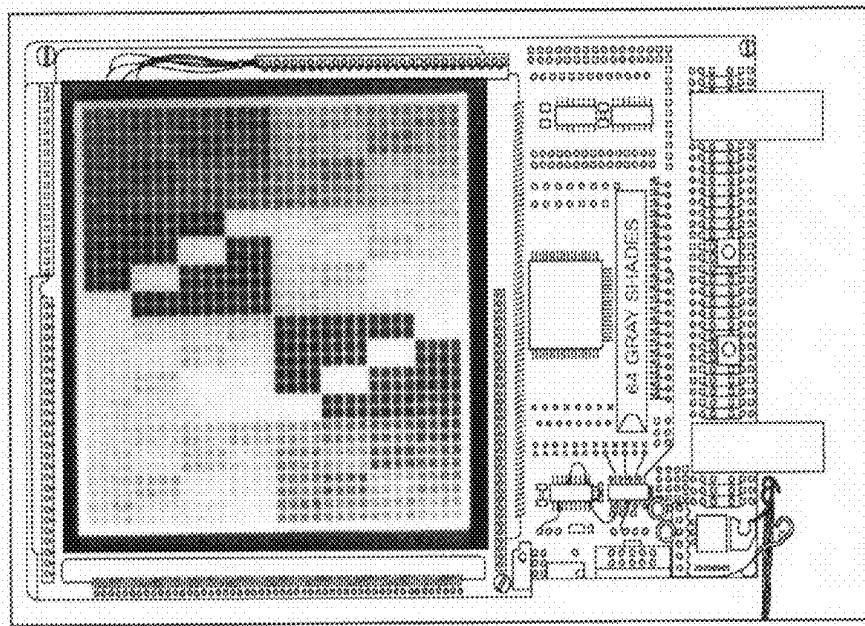

FIG. 4(a)

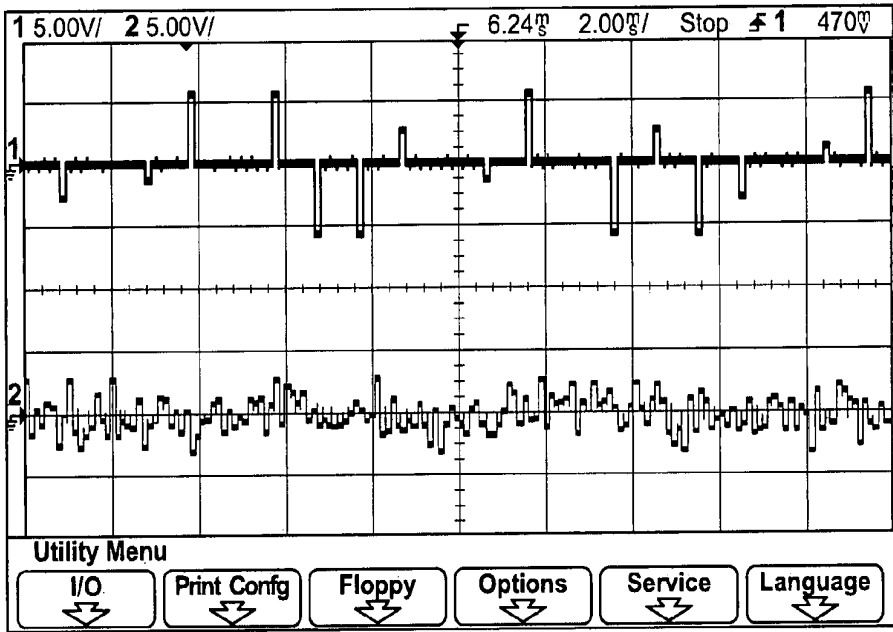

FIG. 5

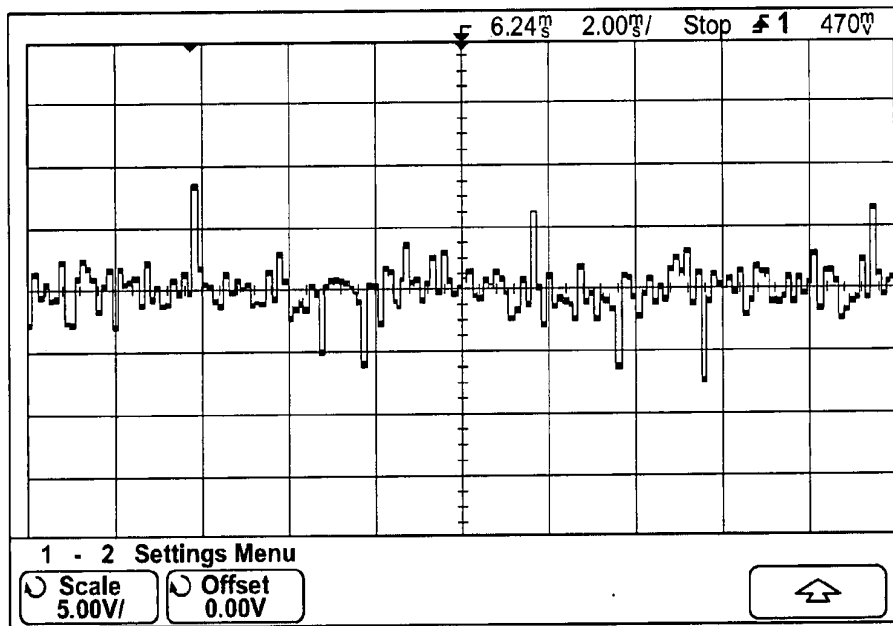

FIG. 6

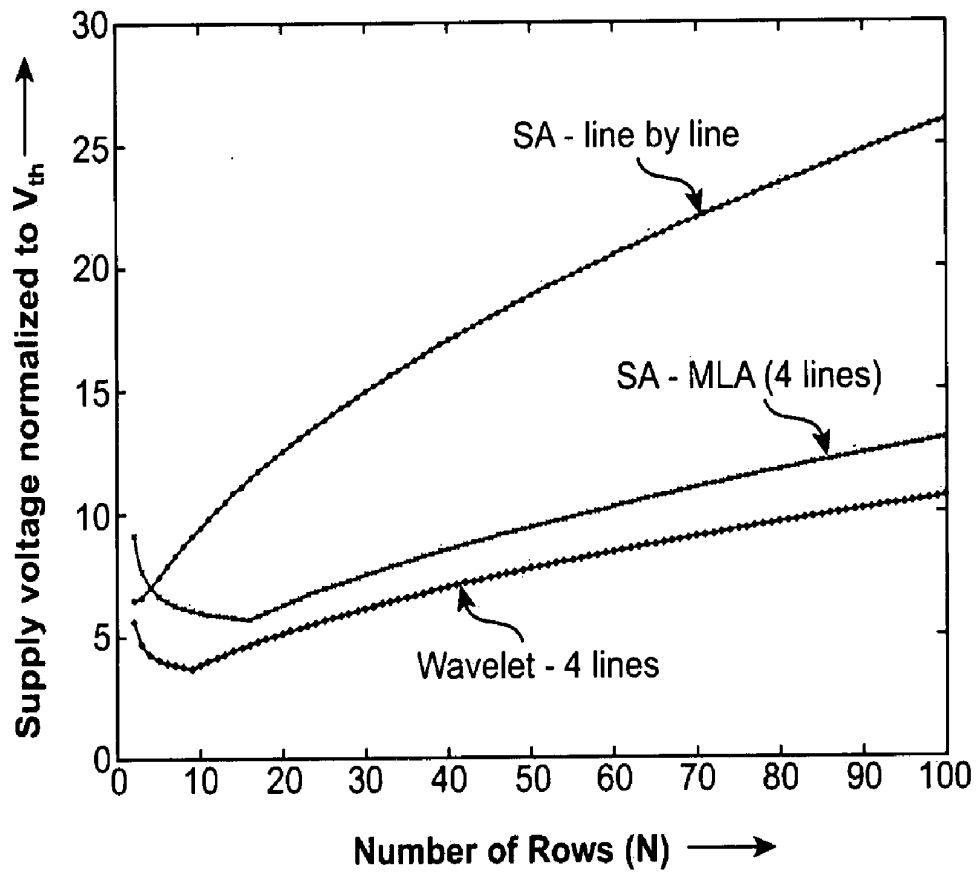

FIG. 7

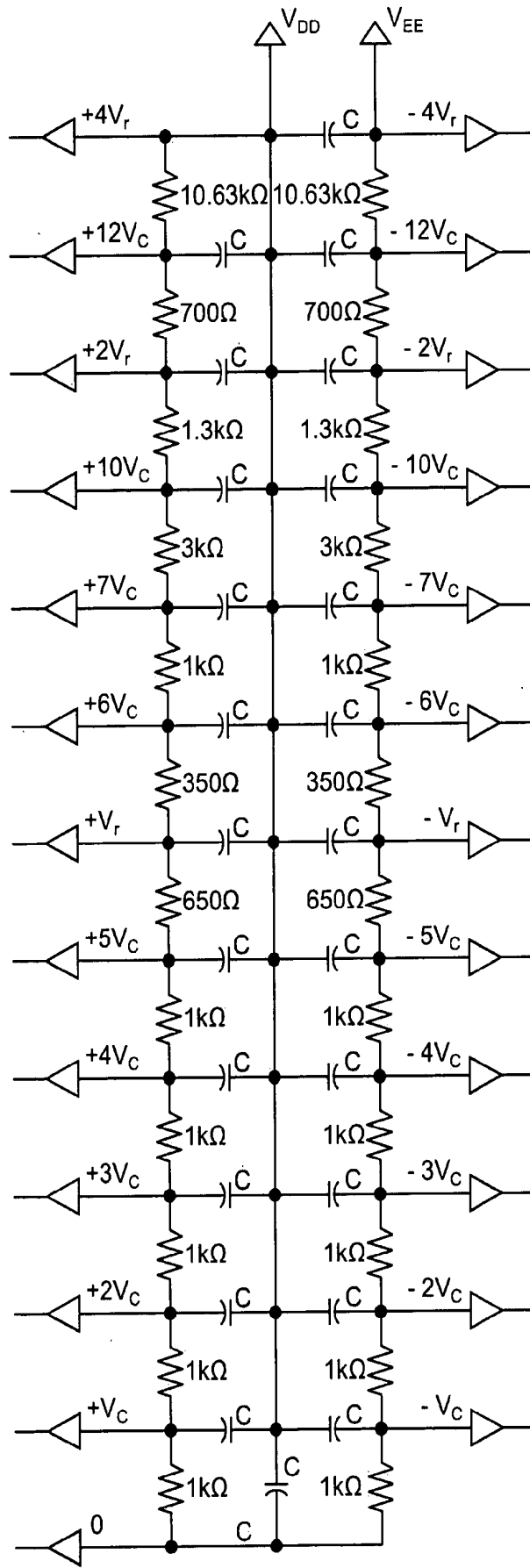

FIG. 8

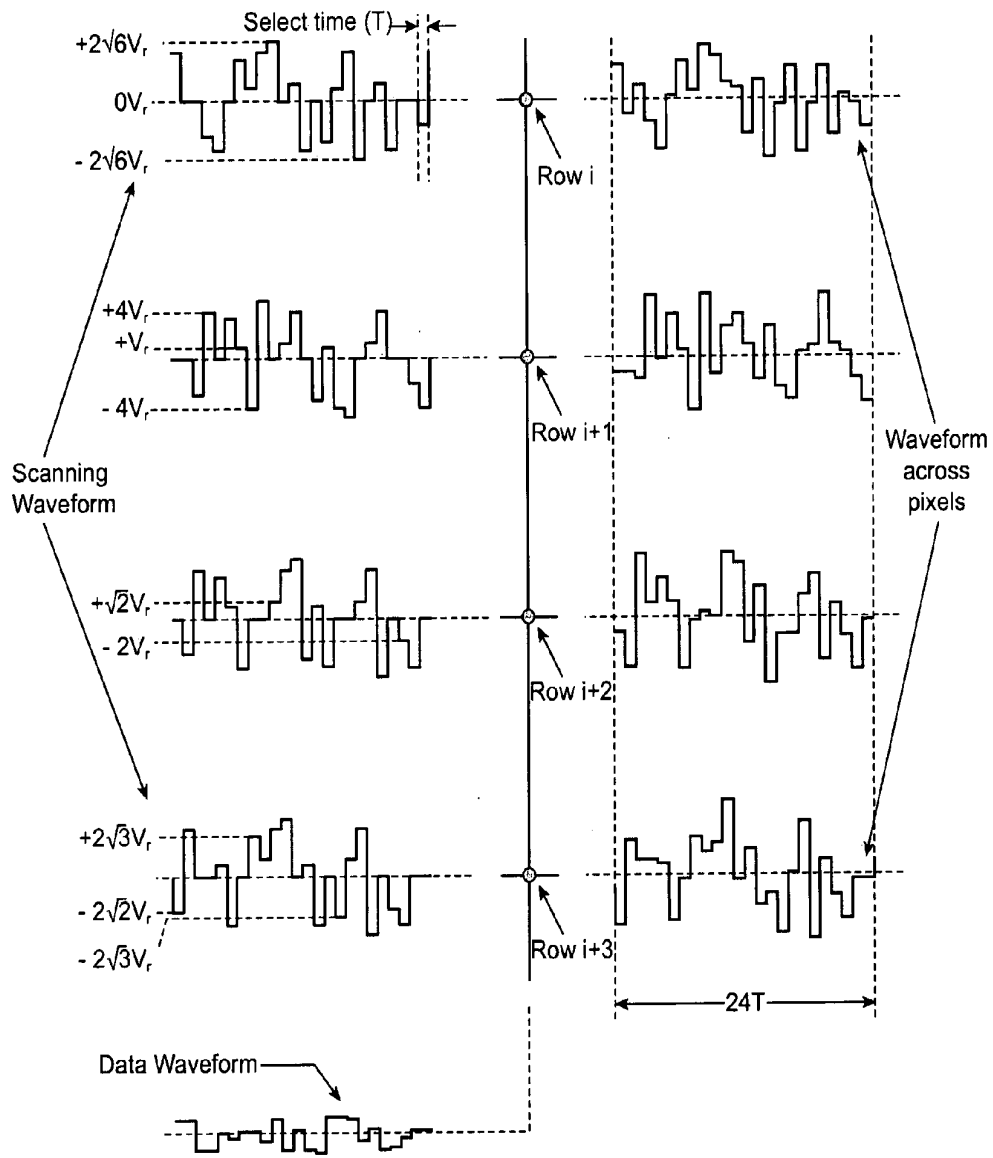

FIG. 9

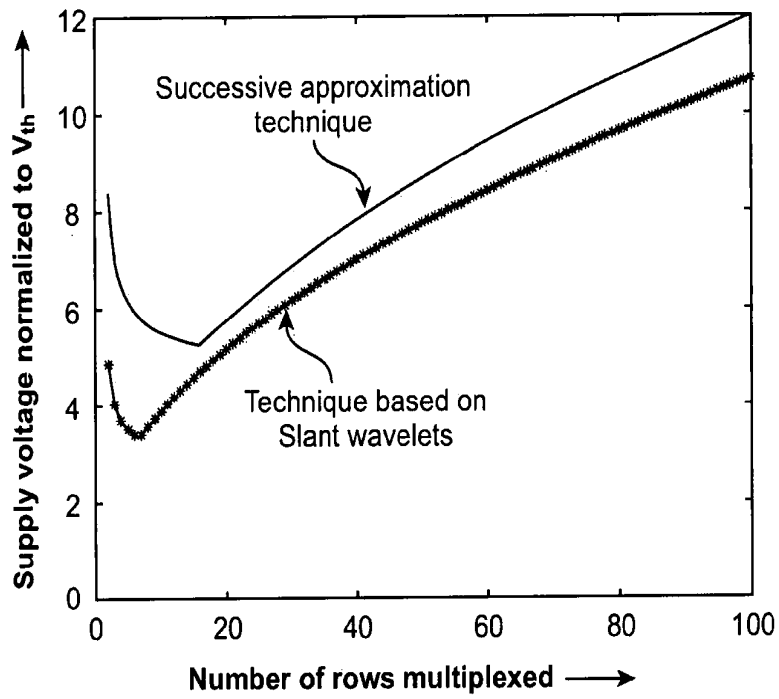

FIG. 10

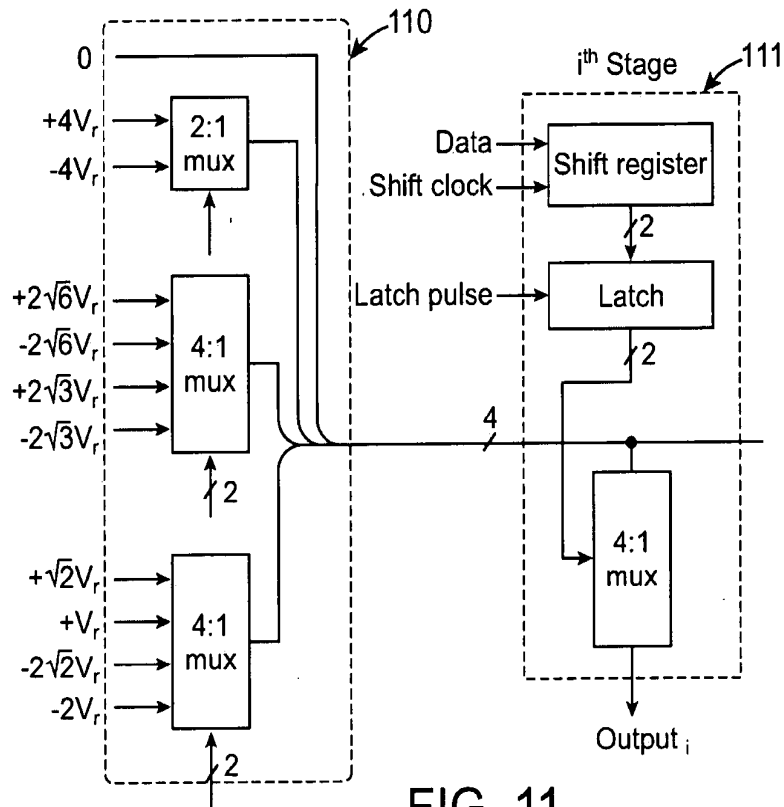
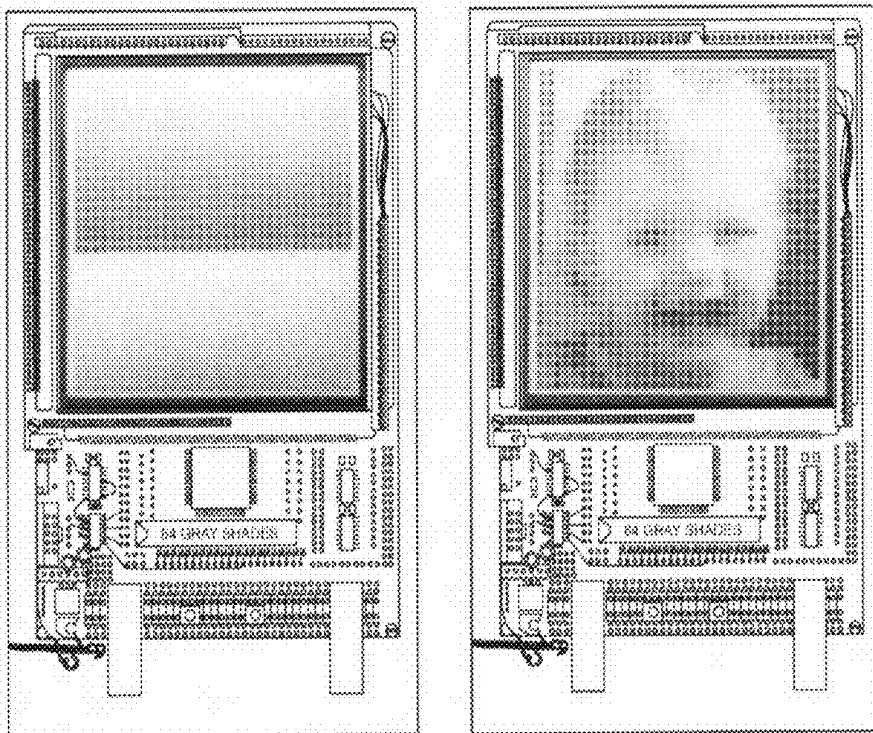
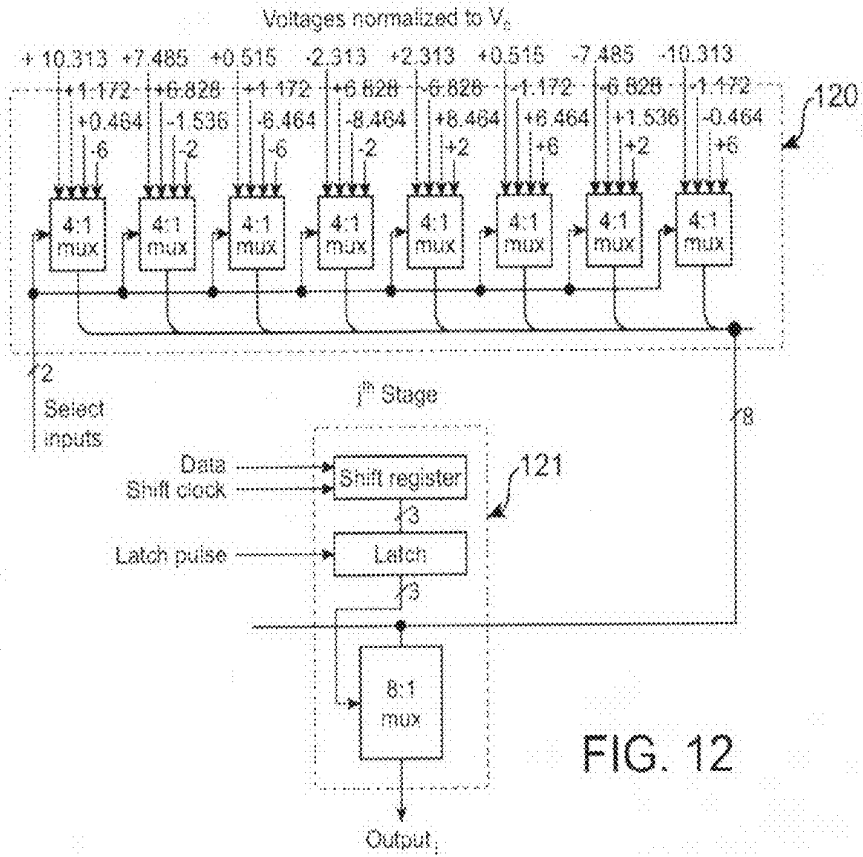

FIG. 11



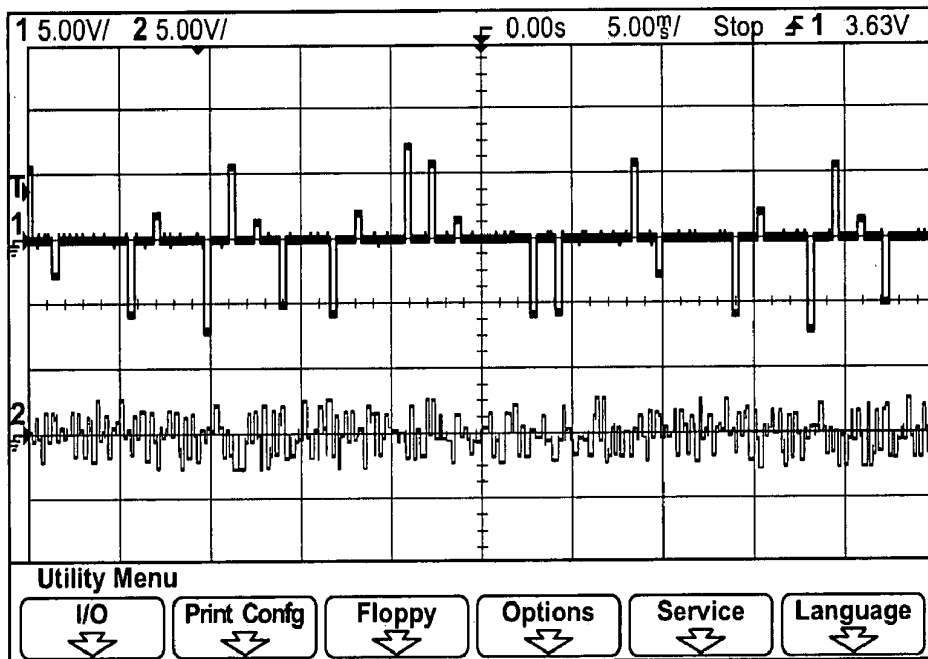

FIG. 14

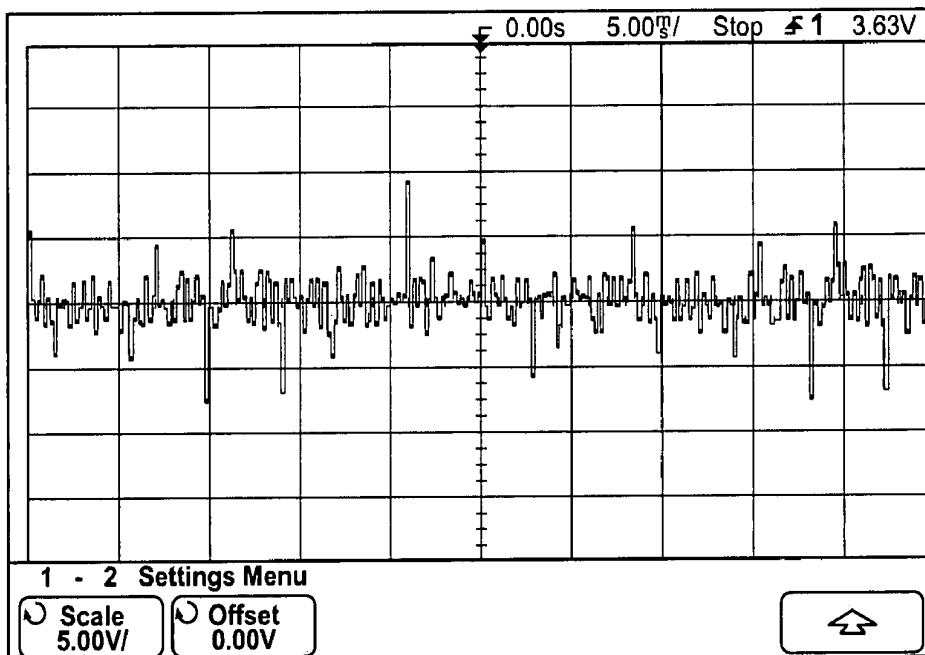

FIG. 15

SYSTEM AND METHOD TO DRIVE DISPLAY MATRIX

FIELD OF INVENTION

[0001] The field of invention is related to Reducing hardware complexity of the display drivers using integer wavelets by adding a few analog multiplexers that are common to a large number of stages (one for each output) in the drivers. A simple controller is implemented in a low cost complex programmable logic device (CPLD). Further, displaying a large number of gray shades in RMS (root-mean-square) responding displays by using integer wavelets. The technique is demonstrated by displaying thirty two and sixty-four gray shades in twisted nematic liquid crystal displays (LCD).

BACKGROUND OF INVENTION AND PRIOR ART

[0002] Capability to display a large number of gray shades is desirable to increase the number of colors and to avoid gray scale contours in images. A larger number of gray shades can be displayed using amplitude modulation [1], successive approximation [2] and wavelet [3] techniques. Several addressing techniques for displaying gray shades in RMS (root-mean-square) responding matrix LCDs are reviewed in [4]. A technique to display eight gray shades using wavelets [3] was presented in the Society for Information Display conference as a proof of the concept. A technique with good reduction in hardware complexity of the drive electronics (drivers as well as the controller) when a large number of gray shades are displayed using integer wavelets and other wavelets are described here.

REFERENCES

- [0003]** [1] T. N. Ruckmongathan, Addressing techniques for RMS responding LCDs—A review, Proc. Japan Display '92, pp 77-80, 1992.
- [0004]** [2] K. G. PaniKumar and T. N. Ruckmongathan, Displaying Gray Shades in Passive Matrix LCDs using Successive Approximation, Proceedings of the 7th Asian Symposium on Information Display (ASID-2002), pp 229-232, 2002.
- [0005]** [3] T. N. Ruckmongathan, Nanditha Rao P and Ankita Prasad, Wavelets for Displaying Gray Shades in LCDs, SID 05 Digest, 2005 Society for Information Display International Symposium Digest of Technical papers, pp 168-171, 2005.
- [0006]** [4] T. N. Ruckmongathan, "Displaying gray shades in liquid crystal displays", Pramana Vol. 61, No. 2, pp. 313-329, 2003.
- [0007]** [5] T. N. Ruckmongathan, Reducing power consumption in passive matrix liquid crystal displays', IEEE trans. On Electron Devices, vol. 53, no. 7, pp. 1559-1566, July 2006.
- [0008]** [6] A. R. Conner and T. J. Scheffer, Pulse height modulation gray shading methods for passive matrix LCDs, Proc. 12th International Display Research Conference (Japan Display '92) pp 69-72, 1992.
- [0009]** [7] Steve Young, James Lee, Berry Lam, Jonathan Ng and Ivan Tsoi, Gray-scale addressing method by multi-order paraunitary/orthogonal building blocks, Journal of the SID 8/4, pp. 283-288, 2000.
- [0010]** [8] T. N. Ruckmongathan, 'A Successive Approximation Technique for Displaying Gray Shades in Liquid

Crystal Displays (LCDs)', IEEE trans. Image Processing, vol. 16, no. 2, pp. 554-561, February 2007.

- [0011]** [9] S. Agaian, K. Tourshan and J. P. Noonan, "Generalized parametric slant Hadamard transform", Signal Processing 84 (2004), pp 1299-1306.

BRIEF DESCRIPTION OF ACCOMPANYING DRAWINGS

[0012] FIG. 1: shows typical waveforms when the scanning of the matrix display is based on integer wavelets. Scanning (row) waveforms have seven voltage levels and the data waveforms have eighteen voltages.

[0013] FIG. 2: shows the fact that "just four voltages are necessary at a given instant of time" is used to reduce the hardware complexity of the row drivers. A 2-bit shift register, 2-bit latch and a 4:1 analog multiplexer are adequate when four (8:1) analog multiplexers are common to all stages of the row drivers (one per each address line) as compared to a 3-bit shift register, 3-bit latch and 8:1 analog multiplexers that are necessary for each output of the row drivers

[0014] FIG. 3: shows the fact that "just eight voltages or less are necessary at a given instant of time" is used to reduce the hardware complexity of the column drivers. A 3-bit shift register, 3-bit latch and an 8:1 analog multiplexer are adequate when eight (4:1) analog multiplexers are shared by all the stages of the column drivers as compared to having a 5-bit shift register, a 5-bit latch and a (18:1) analog multiplexer for each output stage of the column (data) drivers.

[0015] FIG. 4a: shows a photograph of the prototype with sixty-four gray shades being displayed using integer wavelets.

[0016] FIG. 4b: shows a photograph of the prototype that is capable of displaying sixty-four gray shades using integer wavelets.

[0017] FIG. 5: shows a typical row (scanning) and column (data) waveforms when sixty-four gray shades are displayed in a 32x32 matrix LCD. Just half a cycle has been captured on the screen for the sake of clarity.

[0018] FIG. 6: shows a typical waveform across a pixel (row waveform minus the column waveform) in the prototype of the display capable of displaying sixty-four gray shades.

[0019] FIG. 7: shows a plot of supply voltage verses number of scanning electrodes to compare the successive approximation and wavelet-based techniques. Supply voltage for the wavelet-based technique is plotted using the expression in (28).

[0020] FIG. 8: shows a typical voltage level generator.

[0021] FIG. 9: shows typical waveforms when slant (non-integer) wavelets are used to scan the RMS responding matrix displays. The scanning and the data waveforms have nine and eighteen voltages respectively.

[0022] FIG. 10: shows supply voltages of the technique based on slant wavelets as compared with that of the successive approximation technique.

[0023] FIG. 11: shows one stage ('i') of the row drivers having (4:1) analog multiplexer, 2-bit latches and a stage of the 2-bit shift register (to shift in the data serially) is shown inside the box. Two 4:1 analog multiplexers and a 2:1 analog multiplexer that are common to all the stages of the row drivers are useful to reduce the hardware complexity of the row driver circuit.

[0024] FIG. 12: shows drivers with 3-bit shift register, 3-bit latch and a 8:1 analog multiplexers are used as the column drivers considering the fact that the number of voltages cor-

responding to each select vector is either 8 or 4 although the number of voltages in the data (column) waveforms is 24. We have used eight 4:1 analog multiplexers that are common to all the stages of the data drivers to avoid using drivers with 5-bit shift register, 5-bit latch and 24:1 analog multiplexers. Input voltages to the eight (4:1) multiplexers are normalized to V_c .

[0025] FIG. 13: shows photographs of a 32x32 matrix display that is capable of displaying 32 gray shades

[0026] FIG. 14: shows typical row (scanning) and column (data) waveforms when thirty-two gray shades are displayed in a 32x32 matrix LCD.

[0027] FIG. 15: shows typical waveform across a pixel (row waveform minus the column waveform) in the prototype of the display capable of displaying thirty-two gray shades.

OBJECT OF THE INVENTION

[0028] The primary objective of the invention is to develop a system to drive display matrix

[0029] Another objective of the invention is to ensure high quality images (cross-talk free) having good brightness uniformity among pixels that are driven to the same state.

[0030] Yet another objective of the invention is to achieve switching times of the same order when pixels are switched from one arbitrary gray shade to another arbitrary gray shade.

[0031] Another objective of the invention is to develop a voltage level generator to provide predetermined voltages.

[0032] Still another objective of the invention is to develop a row voltage selector to select a group of voltages from the voltage level generator depending on select vector as input voltages to feed to the bus bars of voltages in the row drivers.

[0033] Still another objective of the invention is to develop a column voltage selector to select a group of voltages from the voltage level generator depending on select vector as input voltages to feed to the bus bars of voltages in the column drivers.

[0034] Still another objective of the invention is to develop a controller to generate control signals to scan the display as dictated by addressing technique.

[0035] Yet another main objective of the present invention is to develop a method to reduce driver circuit hardware for displaying gray shades.

[0036] Another objective of the invention is choosing wavelets based on gray shade data bits to form orthogonal matrix wherein each column in the matrix is select vector and the number of rows of the orthogonal matrix is not necessarily equal to the number of gray shade data bits.

[0037] Still another objective of the invention is to choose the number of rows in a groups of scanning electrodes (and also the orthogonal matrix) to be a number that is equal to powers of two (2,4, 8 etc.) to facilitate address generation using the natural binary counter.

[0038] Still another objective of the invention is grouping of scanning electrodes based on number of rows in the matrix and there after constructing data matrix by selecting the gray shade data bits corresponding to elements of the orthogonal matrix wherein each column of the data matrix is a data vector.

[0039] Still another objective of the invention is generating voltages for data electrodes and thereby applying the select vector and the corresponding voltages for the data electrodes in the group.

[0040] Still another objective of the invention is rotating rows of the orthogonal matrix and the data matrix once,

followed by repeating step 'c' until every row of the orthogonal matrix and the data matrix takes position of first row in the respective matrix for displaying gray shades.

STATEMENT OF INVENTION

[0041] The present invention is related to a system to drive display matrix, comprising: a voltage level generator to provide predetermined voltages, a row voltage selector to select a group of voltages from the voltage level generator depending on select vector as input voltages to the row drivers, a column voltage selector to select a group of voltages from the voltage level generator depending on the select vector as input voltages to the column drivers, and a controller to generate control signals to scan the display as dictated by addressing technique; and a method to reduce drivers hardware for displaying gray shades, said method comprises steps of: choosing wavelets based on gray shade data bits to form orthogonal matrix wherein each column in the matrix is select vector and the number of rows of the orthogonal matrix is not necessarily equal to the number of gray shade data bits, grouping of scanning electrodes based on number of rows in the matrix and thereafter constructing data matrix by selecting the gray shade data bits corresponding to elements of the orthogonal matrix wherein each column of the data matrix is a data vector, generating voltages for data electrodes and thereby applying the select vector and the corresponding voltages for the data electrodes in the group, and rotating rows of the orthogonal matrix and the data matrix once, followed by repeating step 'c' until every row of the orthogonal matrix and the data matrix takes position of first row in the respective matrix for displaying gray shades.

DETAILED DESCRIPTION OF INVENTION

[0042] The primary embodiment of the invention is a system to drive display matrix, comprising: a voltage level generator to provide predetermined voltages, a row voltage selector to select a group of voltages from the voltage level generator depending on select vector as input voltages to the row drivers, a column voltage selector to select a group of voltages from the voltage level generator depending on the select vector as input voltages to the column drivers, and a controller to generate control signals to scan the display as dictated by addressing technique.

[0043] In yet another embodiment of the present invention the row drivers select a final voltage from the group of input voltages to drive rows of the display.

[0044] In still another embodiment of the present invention the column drivers select a final voltage from the group of input voltages to drive columns of the display.

[0045] In still another embodiment of the present invention the row and column driver comprises of one stage of shift registers and latches to select the final voltage.

[0046] In still another embodiment of the present invention the voltage selectors are preferably analog multiplexers.

[0047] In still another embodiment of the present invention the row voltage selectors and the column voltage selectors are common to the entire row drivers and column drivers respectively.

[0048] In still another embodiment of the present invention the controller sends control signals to the voltage selectors and the drivers to scan the display.

[0049] In still another embodiment of the present invention the controller comprises a binary counter to generate address of pixels.

[0050] Another main embodiment of the present invention is a method to reduce drivers hardware for displaying gray shades, said method comprises steps of: choosing wavelets based on gray shade data bits to form orthogonal matrix wherein each column in the matrix is select vector and the number of rows of the orthogonal matrix is not necessarily equal to the number of gray shade data bits, grouping of scanning electrodes based on number of rows in the matrix and thereafter constructing data matrix by selecting the gray shade data bits corresponding to elements of the orthogonal matrix wherein each column of the data matrix is a data vector, generating voltages for data electrodes and thereby applying the select vector and the corresponding voltages for the data electrodes in the group, and rotating rows of the orthogonal matrix and the data matrix once, followed by repeating step 'c' until every row of the orthogonal matrix and the data matrix takes position of first row in the respective matrix for displaying gray shades.

[0051] In yet another embodiment of the present invention amplitude of the wavelets is an integer.

[0052] In still another embodiment of the present invention energy of the wavelets is equal to an integer power of two.

[0053] In still another embodiment of the present invention the energy of the wavelet is chosen to correspond uniquely to weight of the gray shade data bit.

[0054] In still another embodiment of the present invention the wavelets are DC free to ensure long life of display.

[0055] In still another embodiment of the present invention the wavelet is selected from the group comprising Haar wavelet, slant wavelet and other orthogonal wavelets

[0056] In still another embodiment of the present invention the voltage for data electrodes is generated using dot product of the select vector and the data vector.

[0057] In still another embodiment of the present invention the voltage for the data electrodes is generated for the entire data electrodes and the entire groups.

[0058] The technique is illustrated with the Haar wavelets and slant wavelets as examples. A similar procedure can be followed for scanning the matrix with other wavelets. The first step is to construct an orthogonal matrix because multiplexing the data to the pixels in the display is possible when the matrix display is scanned with waveforms derived from orthogonal functions or matrices. Selection of wavelets and the construction of an orthogonal matrix with them are described in the next section.

A. Construction of an Orthogonal Matrix Based on Wavelets

[0059] A set of Haar wavelets is chosen and the amplitude of the wavelets are modified such that the following conditions are satisfied:

[0060] 1. Amplitude of the wavelets is an integer.

[0061] 2. Energy of a wavelet is equal to an integer power of two.

[0062] 3. Energy of each wavelet chosen to correspond uniquely to weight of a bit in the gray shade data.

[0063] 4. Wavelets are DC free so that the waveforms across the pixels will also be DC free to ensure long life of the display.

[0064] A set of six wavelets satisfying these conditions are shown in (1) to (6).

$$w_{B5} = \{+4, +4, +4, +4, -4, -4, -4, -4\} \quad (1)$$

$$w_{B4} = \{+4, +4, -4, -4\} \quad (2)$$

$$w_{B3} = \{+4, -4\} \quad (3)$$

$$w_{B2} = \{+2, +2, -2, -2\} \quad (4)$$

$$w_{B1} = \{+2, -2\} \quad (5)$$

$$w_{B0} = \{+1, +1, -1, -1\} \quad (6)$$

[0065] Energies of these wavelets are 128, 64, 32, 16, 8 and 4 respectively and they are proportional (x4) to the weight of the most significant to the least significant bit of the gray shade data. Subscripts B5 to B0 in (1) to (6) correspond to the binary digit (bit) of the gray shade data. The gray shade value $g_{i,j}$ ranges from -63 to +63 in steps of 2 as shown in the following expression.

$$g_{i,j} = \sum_{k=0}^5 2^k \cdot d_k; d_k = \begin{cases} +1 & \forall \text{ logic 0} \\ -1 & \forall \text{ logic 1} \end{cases} \quad (7)$$

[0066] The wavelets in (1) to (6) are combined to form an orthogonal matrix as shown in (8).

$$O(1)_{4 \times 8} = \begin{bmatrix} +4 & -4 & +4 & -4 & +4 & -4 & +4 & -4 \\ +2 & 0 & -2 & 0 & +2 & 0 & -2 & 0 \\ 0 & +4 & 0 & -4 & 0 & +4 & 0 & -4 \\ +2 & +1 & +4 & -1 & -2 & -1 & -4 & +1 \end{bmatrix} \quad (8)$$

[0067] Although it is possible to obtain an orthogonal matrix with just three rows, the number of rows is chosen to be four to reduce the hardware complexity of the controller. Columns of the orthogonal matrix in (8) are referred to as the select vectors. Each element of the orthogonal matrix corresponds to a bit of the gray shade data (d_i) as shown in the matrix $D(1)_{4 \times 8}$ in (9).

$$D(1)_{4 \times 8} = \begin{bmatrix} d_5 & d_5 & d_5 & d_5 & d_5 & d_5 & d_5 & d_5 \\ d_2 & 0 & d_2 & 0 & d_2 & 0 & d_2 & 0 \\ 0 & d_4 & 0 & d_4 & 0 & d_4 & 0 & d_4 \\ d_1 & d_0 & d_3 & d_0 & d_1 & d_0 & d_3 & d_0 \end{bmatrix} \quad (9)$$

[0068] Several orthogonal matrices can be constructed with the wavelets in (1) to (6). Hence the matrix in (8) is not a unique, for example the matrix in (10) and the associated data matrix in (11) could also be used for scanning the matrix LCDs.

$$O(2)_{4 \times 8} = \begin{bmatrix} +4 & -4 & +4 & -4 & +4 & -4 & +4 & -4 \\ 0 & +2 & 0 & -2 & 0 & +2 & 0 & -2 \\ +4 & 0 & -4 & 0 & +4 & 0 & -4 & 0 \\ +4 & +1 & -2 & -1 & -4 & -1 & +2 & +1 \end{bmatrix} \quad (10)$$

$$D(2)_{4 \times 8} = \begin{matrix} & \text{-continued} \\ \begin{bmatrix} d_5 & d_5 & d_5 & d_5 & d_5 & d_5 & d_5 & d_5 \\ 0 & d_2 & 0 & d_2 & 0 & d_2 & 0 & d_2 \\ d_4 & 0 & d_4 & 0 & d_4 & 0 & d_4 & 0 \\ d_3 & d_0 & d_1 & d_0 & d_3 & d_0 & d_1 & d_0 \end{bmatrix} \end{matrix} \quad (11)$$

B. Scanning the Matrix Display

[0069] Consider a matrix display with N and M orthogonal electrodes with picture-elements (pixels) located at the intersection of these address lines. Let the gray shade of the pixel located at the intersection of row ‘i’ and column ‘j’ be $g_{i,j}$ as given in (7). The matrix display may be scanned either by selecting the row electrodes or the column electrodes. The electrodes that are used for scanning the display are called the scanning electrodes and the electrodes that are orthogonal to the scanning electrodes are referred to as the data electrodes. Let the number of scanning electrodes be N. These electrodes are grouped to form about (N/4) sets of scanning electrodes each consisting of four electrodes. The display is scanned by selecting one set (four) of scanning electrodes at a time by applying voltages that are proportional to elements of the select vector. For example, the address lines can be selected by applying $-4V_r$, 0, $+4V_r$ and $+V_r$ when the second column of the matrix in (8) is the select vector (shown in (12)).

$$\begin{bmatrix} -4 \\ 0 \\ +4 \\ +1 \end{bmatrix} \quad (12)$$

[0070] All the other (N-4) non-selected scanning electrodes are grounded. Voltages for the data electrodes are obtained by computing the dot product of the select vector with the data vectors. The data vector is obtained by picking the bits of the gray shade data as dictated by the elements of the column in (9) that corresponds to the select vector. In our example, the bit-5 (MSB) of the pixels located on the first selected electrode, bit-4 of the pixels on the third selected electrode and bit-0 (LSB) of the pixels in the fourth selected electrode are used to form the data vector because the elements of the select vectors correspond to the wavelets in (1), (2) and (6) respectively. Second element of the data vector is zero because the corresponding element of the select vector is also zero. Data voltages for all the data electrodes in the display are computed by using the dot product as shown in (13).

$$V_{data-j} = \begin{bmatrix} -4 \\ 0 \\ +4 \\ +1 \end{bmatrix} \cdot \begin{bmatrix} d_5 \\ 0 \\ d_4 \\ d_0 \end{bmatrix} \cdot V_c \quad (13)$$

[0071] Select and data voltages are applied to the respective electrodes simultaneously during a time interval T, referred to as the select time. A frame is complete when all the (N/4) sets of scanning electrodes are selected with all the select vectors of (8). At the end of the frame, energy delivered to the pixels

in the first electrode of all the sets is proportional to the most significant bit of the gray shade data because the energy of the wavelet in the first row of the orthogonal matrix in (8) corresponds to the most significant bit. Similarly, the energies delivered to the second and third rows of the sets are proportional to the bit-2 and bit-4 respectively. Energy delivered to the pixels in the fourth row is proportional to the sum of the energies of the bit-3, bit-1 and bit-0. Three more frames are necessary to ensure that the energy delivered to all the pixels in the display is proportional to the sum of the energies corresponding to all the bits of the gray shade data. Hence, (8N) time intervals are necessary to complete a cycle. The orthogonal matrix in (8) and the corresponding matrix in (9) are rotated three times (row wise) and the scanning is performed so that the three additional frames will complete a cycle. For example, rotating the matrix down once will ensure that the first row of each set of the scanning lines will get energy that is proportional to the sum of the energies of bit-3, bit-1 and bit-0. Energies delivered to the second, third and fourth lines in each set of scanning lines will be proportional to that of the bit-5, bit-2 and bit-4 respectively. Orthogonal matrices for the second, third and the fourth frames and their corresponding data matrices are given in (14)-(19).

$$O(2)_{4 \times 8} = \begin{bmatrix} +2 & +1 & +4 & -1 & -2 & -1 & -4 & +1 \\ +4 & -4 & +4 & -4 & +4 & -4 & +4 & -4 \\ +2 & 0 & -2 & 0 & +2 & 0 & -2 & 0 \\ 0 & +4 & 0 & -4 & 0 & +4 & 0 & -4 \end{bmatrix} \quad (14)$$

$$D(2)_{4 \times 8} = \begin{bmatrix} d_1 & d_0 & d_3 & d_0 & d_1 & d_0 & d_3 & d_0 \\ d_5 & d_5 & d_5 & d_5 & d_5 & d_5 & d_5 & d_5 \\ d_2 & 0 & d_2 & 0 & d_2 & 0 & d_2 & 0 \\ 0 & d_4 & 0 & d_4 & 0 & d_4 & 0 & d_4 \end{bmatrix} \quad (15)$$

$$O(3)_{4 \times 8} = \begin{bmatrix} 0 & +4 & 0 & -4 & 0 & +4 & 0 & -4 \\ +2 & +1 & +4 & -1 & -2 & -1 & -4 & +1 \\ +4 & -1 & +4 & -1 & +4 & -4 & +4 & -4 \\ +2 & 0 & -2 & 0 & +2 & 0 & -2 & 0 \end{bmatrix} \quad (16)$$

$$D(3)_{4 \times 8} = \begin{bmatrix} 0 & d_4 & 0 & d_4 & 0 & d_4 & 0 & d_4 \\ d_1 & d_0 & d_3 & d_0 & d_1 & d_0 & d_3 & d_0 \\ d_5 & d_5 & d_5 & d_5 & d_5 & d_5 & d_5 & d_5 \\ d_2 & 0 & d_2 & 0 & d_2 & 0 & d_2 & 0 \end{bmatrix} \quad (17)$$

$$O(4)_{4 \times 8} = \begin{bmatrix} +2 & 0 & -2 & 0 & +2 & 0 & -2 & 0 \\ 0 & +4 & 0 & -4 & 0 & +4 & 0 & -4 \\ +2 & +1 & +4 & -1 & -2 & -1 & -4 & +1 \\ +4 & -4 & +4 & -4 & +4 & -4 & +4 & -4 \end{bmatrix} \quad (18)$$

$$D(4)_{4 \times 8} = \begin{bmatrix} d_2 & 0 & d_2 & 0 & d_2 & 0 & d_2 & 0 \\ 0 & d_4 & 0 & d_4 & 0 & d_4 & 0 & d_4 \\ d_1 & d_0 & d_3 & d_0 & d_1 & d_0 & d_3 & d_0 \\ d_5 & d_5 & d_5 & d_5 & d_5 & d_5 & d_5 & d_5 \end{bmatrix} \quad (19)$$

[0072] In summary, a cycle is complete when all the set of scanning electrodes are selected with all the select vectors in the orthogonal matrices of (8), (14), (16) and (18) once. Typical waveforms based on the orthogonal matrix in (10) are shown in FIG. 1. Each select vector in (10) is rotated to obtain three other select vectors. The waveforms across the pixels are DC free because the wavelets in these orthogonal matrices are DC free.

Analysis

[0073] The RMS voltage across pixels in the display when the display is scanned with waveforms derived from wavelets is as follows.

$$V_{pixel}(RMS) = \sqrt{\frac{4 \sum_{k=0}^5 2^k (V_r^2 - 2 \cdot d_{k,i,j} V_r \cdot V_c + N \cdot V_c^2)}{8N}} \quad (20)$$

$$V_{ON}(RMS) = \sqrt{\frac{63(V_r^2 + 2V_r \cdot V_c + N \cdot V_c^2)}{2N}} \quad (21)$$

$$V_{OFF}(RMS) = \sqrt{\frac{63(V_r^2 - 2V_r \cdot V_c + N \cdot V_c^2)}{2N}} \quad (22)$$

[0074] The selection ratio, defined as the ratio of RMS voltage across the ON pixels to that across OFF pixels is a maximum when

$$\frac{V_r}{V_c} = \sqrt{N} \quad (23)$$

$$\text{and the maximum selection ratio is } \frac{V_{ON}}{V_{OFF}} = \sqrt{\frac{\sqrt{N} + 1}{\sqrt{N} - 1}} \quad (24)$$

[0075] It is the maximum selection ratio that is attainable by any addressing technique for driving passive matrix LCDs. Selection ratio is a measure of the discrimination that can be achieved between ON and OFF pixels and a higher selection ratio will ensure good contrast in the display. The OFF pixels in the display are biased near the threshold voltage of the LCD and the supply voltage of the drive electronics is obtained by equating the expression for the voltage across OFF pixels to the threshold voltage of the LCD.

$$V_{OFF} = \sqrt{\frac{63(2N - 2\sqrt{N})}{2N}} \cdot V_c = V_{threshold} \quad (25)$$

$$\text{Hence, } V_c = \frac{V_{threshold}}{\sqrt{63 \left(1 - \frac{1}{\sqrt{N}}\right)}} \quad (26)$$

[0076] Supply voltage is determined by the maximum swing in the addressing waveforms. Maximum amplitude of the scanning waveforms is small as compared to that of the data voltages when N is small. It is higher than the maximum amplitude of the data voltages when N is large. Hence, the supply voltage is defined for two ranges of N. Maximum swing in the data waveform is also dependent on the orthogonal matrix. For example, the maximum amplitude is $10 V_c$ when the orthogonal matrix in (8) is used where as it is $12 V_c$ when the matrix in (10) is used. Supply voltage when orthogonal matrix in (8) is used is:

$$V_{s(8)} = \begin{cases} 20V_c & \forall N \leq 6 \\ 8\sqrt{N} V_c & \forall N > 6 \end{cases} \quad (27)$$

[0077] The supply voltage when matrix of (10) is used for scanning the display is given in (28).

$$V_{s(10)} = \begin{cases} 24V_c & \forall N \leq 9 \\ 8\sqrt{N} V_c & \forall N \geq 9 \end{cases} \quad (28)$$

$$\text{Supply voltage}_{(N \geq 9)} = 8 \cdot V_r = 8\sqrt{N} V_c = \frac{8\sqrt{N} V_{threshold}}{\sqrt{63 \left(1 - \frac{1}{\sqrt{N}}\right)}} \quad (29)$$

[0078] The analysis presented in the previous section is independent of the scanning sequence, the order in which the scanning electrodes are selected with select vectors. There are $32!$ ways of selecting a set of four electrodes with the thirty-two select vectors and the $(N/4)$ sets of scanning electrodes themselves may be selected in $(N/4)!$ ways. The RMS voltage across the pixel will not change with the scanning sequence but the frequency spectrum across the pixels and the power consumption of the display will depend on the scanning sequence [5].

Drive Electronics

[0079] The techniques to reduce the hardware complexity of the drive electronics are outlined in this section.

C. Reducing the Hardware Complexity

1) Row (Scan) Drivers

[0080] The number of voltages in the scanning waveforms is seven viz., $\pm 4 V_r$; $\pm 2 V_r$; $\pm V_r$ and 0. Data drivers that are capable of applying any one of the eight voltages to each electrode may be used. They consist of an 8:1 analog multiplexer, a 3-bit latch and 3-bit shift register in each stage that corresponds to one output of the driver. However, by considering the fact that just four voltages are necessary (three select voltages and a non-select voltage), it is adequate to have a 4:1 analog multiplexer, 2-bit latch and 2-bit shift register in each stage of the display driver along with row voltage selector (201) with four 8:1 analog multiplexers that are common to all the row drivers (202) in the display. The hardware reduction achieved in each stage of the driver contributes to a large reduction in the hardware complexity because the number of stages in the drivers is equal to N, the number of scanning electrodes in a display and N is usually large. Hence, the reduction in hardware is significant while the increase in hardware (four 8:1 multiplexers) to achieve this reduction is negligible. Schematic diagram of a simplified row drive circuit is shown in FIG. 2.

2) Column (Data) Drivers

[0081] Number of voltages in the data waveforms is either seventeen or eighteen depending on the selection of the matrix ((8) or (10)) for scanning the display. Hence, each stage of the column driver should have a (17:1) or a (18:1) analog multiplexer, a 5-bit latch to hold the value of the column data during the select time and a 5-bit shift register so that the column data can be serially shifted in to the driver. Here again the number of voltages that are necessary at a given instant of time is just four to eight depending on the select vector. Hence, LCD drivers that are capable of applying just eight voltage levels (with an 8:1 analog multiplexer, 3-bit latch and 3-bit shift register for each output) are adequate for

the column driver (302) and the increase in hardware complexity due to the addition of column voltage selector (301) with eight 4:1 analog multiplexers that are common to all the stages in the driver is negligible because the number of data (column) electrodes is usually large. External multiplexers for the data drivers are shown in the FIG. 3.

3) Controller

[0082] Gray shade data of the pixels in a matrix display is stored in the buffer memory as a one-dimensional array and the address of a pixel in 'row-i' and 'column-j' is computed as follows.

$$\text{Address}=(i-1).M+j-1 \quad (30)$$

[0083] Address of the four pixels in each column has to be generated repeatedly and a simple binary counter can be used provided the number of memory locations allocated for each row is an integer power of two and the number of electrodes that are in a set is also an integer power of two. We have avoided the computation of the address by having four rows in a set and a binary counter can be used to generate the address without any multiplication and addition.

D. Implementation

[0084] The orthogonal matrix in (10) is used to scan a 32x32 twisted nematic matrix display. The number of voltages in the data waveform is 18 instead of the 17 for the matrix in (8). However, this does not change the hardware complexity of the data drivers because we have used drivers that are capable of applying 1 out of 8 eight voltages. The controller is implemented in a CPLD (XCR 3256 XL) with 84 macrocells, 181 product terms and 55 registers. Photograph of the prototype is shown in FIG. 4. Typical row (scanning) and column (data) waveforms are shown in FIG. 5. Typical waveform across a pixel is shown in FIG. 6.

Comparison

[0085] Most of the techniques that were proposed by various researchers during the last century were primarily for displaying bi-level images. Number of time intervals to complete a cycle increases when frame modulation or pulse width modulation are employed to display gray shades. Number of time intervals in a cycle is (126N) when 64 gray shades are displayed using frame or pulse width modulation. The number of time intervals in a cycle includes polarity inversion to achieve DC free waveforms across the pixels. Number of time intervals for all the techniques in this comparison is the minimum number of time intervals to achieve DC free operation. On the other hand, number of voltages in the drive waveforms increases when amplitude modulation or pulse height modulation [6] is used along with line-by-line and multi-line addressing techniques. Amplitude modulation will have 126 voltages in the column waveforms, 3 voltages in the data waveforms and it needs 4N time intervals to complete a cycle. A gray shade technique that is based on multi-ordered orthogonal matrix which was proposed by Young et al. [7] can display a large number of gray shades with less time intervals but the number of voltages in the data waveforms will be large. For example, thirty-five voltages in the data waveforms are necessary to display sixty-four gray shades although the number of voltages in scanning waveforms and the number of time intervals to complete a cycle are small (3 and 12N respectively). It is not possible to reduce the hardware com-

plexity of the drive electronics if amplitude modulation, pulse height modulation [6] and the technique based on multi-ordered orthogonal matrices [7] are used for displaying a large number of gray shades. Number of time intervals to complete a cycle will be too large if paraunitary matrices are used to display a large number of gray shades. It may be more appropriate to compare the wavelet-based technique with the successive approximation techniques [2], [8] since both the techniques are based on delivering energies that are proportional to the bit weight of the gray shade data in several time intervals. A comparison of the wavelet based technique with successive approximation techniques based on line-by-line addressing and multi-line addressing is given in Table 1.

TABLE I

COMPARISON OF THE GRAY SHADE TECHNIQUES (64 GRAY SHADES)			
Parameter	Successive approximation technique	Successive approximation (MLA)	Wavelet based techniq
Number of time intervals for 64 gray shades	12N	12N	8N
Supply voltage	High (100%)*	Intermediate (50%)	Low (40.8%)
Number of voltages in scanning waveforms	13 (19 for IAPT)	13	7
Number of voltages in the data waveforms	12 (19 for IAPT)	17	17

*Supply voltage as a ratio is given as compared to Successive approximation (line-by-line technique). Number is valid for $N > 16$ in case of SA-MLA and $N > 9$ in case of Wavelet based technique.

[0086] The number of rows is chosen to be four in case of multi-line addressing. The number of time intervals to complete a cycle is less for the wavelet based technique and hence the display can be scanned at a lower rate as compared to the successive approximation technique when all other parameters are equal. Slow scanning is helpful to reduce the power consumption. The brightness non-uniformity of pixels due to distortion in the addressing waveforms will also be less because the select time is larger when the number of time intervals is small. A lower supply voltage of the wavelet-based technique is advantageous in portable devices. Supply voltage of the wavelet-based technique is compared with that of the successive approximation techniques [2], [8] in FIG. 7. It is possible to reduce the hardware complexity of the drive electronics in successive approximation technique and the technique proposed in this paper. LCD drivers that are used for displaying bi-level images can be used for displaying gray shades by adding some multiplexers that are common to all the drivers for the successive approximation techniques [8]. Response of the display for different gray shades was measured using a cell (3.9 μm) filled with RO-TN 403 (liquid crystal mixture) when thirty-two rows are scanned with waveforms derived from the orthogonal matrix in (10). The refresh rate is 50 Hz. Table II and Table III shows the response times in milliseconds when the pixels are switched from one gray shade to another using the wavelet based technique. Rise time and fall times are measured from 10% to 90% change in transmission of the difference in transmission between two states. The upper triangle in this table shows the rise times and the lower triangle gives the fall times. Response of the cell was also measured when it is switched to ON and OFF states using voltages under multiplexed condition, by applying square waveforms with RMS voltage equal to V_{ON} (1.58 volts) and V_{OFF} (1.33 volts, the threshold of the liquid crystal

mixture) for the sake of comparison. Switch ON (rise) and switch OFF (fall) times were 53 and 34 ms respectively. The cell is not optimized for fast response. From the Tables II and III it is evident that the response times are slightly higher under multiplexed condition when the pixels are switched from one extreme to the other extreme state (i.e. ON and OFF). However, the gray scale to gray scale switching can be high by a factor of about 2.5 in some cases, when thirty-two lines are multiplexed.

CONCLUSION

[0087] Salient features of the wavelet-based techniques are as follows:

[0088] 1. Amplitude and the number of time intervals in the wavelets are selected with an aim to reduce the supply voltage of the drive electronics

[0089] 2. A compact orthogonal matrix is constructed to reduce the number of time intervals in a cycle.

[0090] 3. Number of non-zero elements in the select vector is chosen to reduce the hardware complexity of the drivers.

[0091] 4. Number of non-zero elements in the select vector may also be used to match the drivers on a given display panel.

[0092] 5. Number of rows in the orthogonal matrix can be chosen to be an integer power of two to reduce the hardware complexity of the controller.

[0093] These features are unique to the wavelet-based technique and hence they have several advantages as compared to the conventional techniques for displaying gray shades.

TABLE II

RESPONSE TIMES (IN MILLISECONDS) WHEN PIXELS ARE SWITCHED TO DIFFERENT GRAY SHADES USING WAVELETS ($V_{SUPPLY} = 8.78 V$).

Gray shade value	0 (OFF)	3	7	11	15	19	23	27	31	35	39	43	47	51	55	59	63 (ON)
0 (OFF)	—	124	118	118	114	105	102	98	95	92	96	90	88	87	85	78	74
3	96	—	120	112	114	100	96	91	88	85	82	82	80	74	73	71	70
7	92	100	—	120	116	100	97	93	90	88	83	86	87	85	80	70	68
11	90	98	99	—	118	112	102	98	96	90	94	88	84	80	76	72	66
15	85	90	92	104	—	115	110	101	97	95	90	93	90	82	79	74	71
19	79	86	88	100	105	—	116	112	106	100	93	94	90	84	80	74	73
23	70	79	84	94	98	104	—	114	115	108	98	95	92	85	81	76	75
27	70	72	78	92	93	98	108	—	122	120	116	99	94	87	83	77	76
31	67	70	75	88	91	96	100	110	—	126	112	104	98	89	86	82	82
35	65	77	78	89	88	92	96	104	110	—	120	112	102	96	93	88	86
39	62	72	74	85	86	87	88	106	100	108	—	119	116	107	103	92	88
43	68	70	75	80	80	84	85	88	90	103	114	—	113	109	106	97	89
47	62	64	70	76	80	78	82	83	86	90	98	104	—	115	108	101	93
51	62	64	70	74	78	79	76	75	84	82	96	100	104	—	114	98	95
55	55	65	71	78	76	77	69	74	82	78	92	95	101	107	—	116	105
59	50	68	65	74	75	70	66	72	80	74	86	84	94	92	102	—	118
63 (ON)	58	65	60	72	77	72	68	70	76	69	75	80	88	91	95	108	—

[0094] Upper triangle in the table gives the rise time and the lower triangle of the table gives the fall time when the pixels when they are switched from one gray shade to another. Rise time and fall times are measured from 10% to 90% change in transmission of the difference in transmission between two states.

TABLE III

RESPONSE TIMES (IN MILLISECONDS) WHEN PIXELS ARE SWITCHED TO DIFFERENT GRAY SHADES USING WAVELETS ($V_{SUPPLY} = 8.36 V$).

Gray shade value	0 (OFF)	3	7	11	15	19	23	27	31	35	39	43	47	51	55	59	63 (ON)
0 (OFF)	—	132	130	121	125	120	116	110	106	102	95	94	80	86	85	77	66
3	58	—	138	130	124	118	114	115	116	114	110	106	94	88	82	78	74
7	60	80	—	130	128	125	120	116	106	100	100	103	100	94	90	82	79
11	52	72	96	—	129	124	120	118	115	108	104	110	108	95	93	86	84
15	56	68	90	100	—	122	116	120	115	112	110	114	110	104	96	88	86
19	60	70	80	92	108	—	128	124	122	116	110	100	100	88	86	74	78
23	48	65	72	88	104	116	—	128	115	118	108	116	112	106	102	92	90
27	62	67	70	90	96	110	116	—	132	128	114	110	96	84	88	86	80

TABLE III-continued

RESPONSE TIMES (IN MILLISECONDS) WHEN PIXELS ARE SWITCHED TO DIFFERENT GRAY SHADES USING WAVELETS ($V_{SUPPLY} = 8.36$ V).																	
Gray shade value	0 (OFF)	3	7	11	15	19	23	27	31	35	39	43	47	51	55	59	63 (ON)
31	55	65	66	90	93	98	110	120	—	130	126	115	106	108	102	90	88
35	51	68	67	88	89	95	110	120	123	—	128	110	104	96	94	85	84
39	58	66	71	78	86	84	104	108	120	116	—	132	113	98	95	87	86
43	60	65	70	80	84	85	102	98	100	95	120	—	124	116	100	88	90
47	50	65	72	78	84	80	95	82	94	88	100	111	—	120	116	96	92
51	50	60	60	70	80	83	94	84	92	75	89	88	112	—	125	110	92
55	55	56	58	70	80	82	90	82	88	72	88	80	110	118	—	115	100
59	49	56	60	66	77	73	80	78	84	70	76	73	92	96	100	—	118
63 (ON)	47	48	60	66	74	70	66	74	80	75	70	73	82	90	90	110	—

[0095] The invention is further elaborated with following example however these examples should not be considered to limit the scope of the invention. Below shows an example of using slant wavelet instead of Harr wavelet.

Slant Wavelets and Construction of an Orthogonal Matrix

[0096] An orthogonal slant matrix proposed by S. Agaian [5] is shown in (31).

$$S_3 = \begin{bmatrix} 1 & 1 & 1 \\ \frac{\sqrt{6}}{2} & 0 & \frac{-\sqrt{6}}{2} \\ \frac{\sqrt{2}}{2} & -\sqrt{2} & \frac{\sqrt{2}}{2} \end{bmatrix} \quad (31)$$

[0097] We have derived five wavelets from the orthogonal matrix S_3 and they satisfy the following conditions:

[0098] 1. Energy of a wavelet is proportional to weight of a bit of the gray shade data.

[0099] 2. Each wavelet is uniquely associated with one bit of the data.

[0100] 3. DC free wavelets to ensure long life of the display (application of DC voltages for a long duration will reduce the life of the display).

Five wavelets that satisfy these conditions are shown in (32) to (36).

$$w_{B4} = \{+4, +4, +4, -4, -4, -4\} \quad (32)$$

$$w_{B3} = \{+2\sqrt{6}, 0, -2\sqrt{6}\} \quad (33)$$

$$w_{B2} = \{+2\sqrt{3}, 0, -2\sqrt{3}\} \quad (34)$$

$$w_{B1} = \{+\sqrt{2}, -2\sqrt{2}, +\sqrt{2}\} \quad (35)$$

$$w_{B0} = \{+1, -2, +1\} \quad (36)$$

[0101] These wavelets are more complex as the compared to the Harr wavelet. However, use of these wavelets does not increase the hardware complexity of the drive electronics is explained here. Energies of these wavelets are 96, 48, 24, 12 and 6 respectively and they are proportional (x6) to the weight of bits in gray shade data. Subscripts B4 to B0 in (32) to (36) correspond to the binary weight of the gray shade data as shown in the following expression.

$$g_{i,j} = \sum_{k=0}^4 2^k \cdot d_k; d_k = \begin{cases} +1 & \forall \text{ logic } 0 \\ -1 & \forall \text{ logic } 1 \end{cases} \quad (37)$$

[0102] Values of the gray shades $g_{i,j}$ range from -31 to $+31$ and adjacent gray shade values differ by 2. Orthogonal matrices can be constructed with the wavelets in (32) to (36) and one such matrix is shown in (38).

$$O_{4 \times 6} = \begin{bmatrix} +4 & -4 & +4 & -4 & +4 & -4 \\ +2\sqrt{6} & 0 & 0 & 0 & -2\sqrt{6} & 0 \\ 0 & +2\sqrt{3} & 0 & 0 & 0 & -2\sqrt{3} \\ +\sqrt{2} & +1 & -2\sqrt{2} & -2 & +\sqrt{2} & +1 \end{bmatrix} \quad (38)$$

[0103] Number of rows in the orthogonal matrix is chosen to be four to reduce the hardware complexity of the controller as explained before. Several orthogonal matrices can be obtained by using the wavelets in (32) to (36). An orthogonal matrix with three rows is shown in (39).

$$O_{3 \times 6} = \begin{bmatrix} +4 & +4 & +4 & -4 & -4 & -4 \\ +2\sqrt{6} & 0 & -2\sqrt{6} & +2\sqrt{3} & 0 & -2\sqrt{3} \\ +\sqrt{2} & -2\sqrt{2} & +\sqrt{2} & +1 & -2 & +1 \end{bmatrix} \quad (39)$$

[0104] Columns of the orthogonal matrix are referred to as the select vectors. Each element of the select vector corresponds to a bit of the gray shade data (d_j). Data bits corresponding to the elements of the matrices in (38) and (39) are shown in (40) and (41) respectively.

$$D_{4 \times 8} = \begin{bmatrix} d_4 & d_4 & d_4 & d_4 & d_4 & d_4 \\ d_3 & x & x & x & d_3 & x \\ x & d_2 & x & x & x & d_2 \\ d_1 & d_0 & d_1 & d_0 & d_1 & d_0 \end{bmatrix} \quad (40)$$

-continued

$$D_{3 \times 6} = \begin{bmatrix} d_4 & d_4 & d_4 & d_4 & d_4 & d_4 \\ d_3 & x & d_3 & d_2 & x & d_2 \\ d_1 & d_1 & d_1 & d_0 & d_0 & d_0 \end{bmatrix} \quad (41)$$

[0105] The 'x' in data bit matrices corresponds to the zero in the orthogonal matrices.

Technique Using Slant Wavelet

[0106] Consider a matrix display with N and M electrodes that are orthogonal to each other and picture elements (pixels) located at the intersection of these address lines. Let the gray shade of a pixel located at the intersection of row 'i' and column 'j' be $g_{i,j}$ as given in (37). Address lines in the matrix display are grouped in to (N/4) sets such that each set consists of four address lines. Steps involved in scanning the matrix display are as follows:

- [0107]** 1. A column in the orthogonal matrix (one of the select vectors) in (38) is chosen to select a set of address lines.
- [0108]** 2. Data vector of each column in the matrix display is obtained by selecting the data bits corresponding to the select vector (as shown in the corresponding column of the data bit matrix (40)).
- [0109]** 3. Data voltages (dot product of the select vector with the data vectors) are computed. For example, the data voltage when the select vector is the first column of the orthogonal matrix in (38) is as follows:

$$V_{data} = \begin{bmatrix} +4 \\ +2\sqrt{6} \\ 0 \\ +\sqrt{2} \end{bmatrix} \cdot \begin{bmatrix} d_4 \\ d_3 \\ 0 \\ d_1 \end{bmatrix} \cdot V_c \quad (42)$$

Here, d_4 , d_3 and d_1 correspond to pixels in the first, second and fourth address lines of the selected subset. Subscripts (4 to 0) correspond to bits i.e., the most significant bit (MSB) to the least significant bit (LSB).

- [0110]** 4. Four address lines in a set are selected simultaneously for a time duration T (referred to as the select time) with voltages corresponding to one of the select vector. For example, the address lines are selected by applying the voltages $+4V_r$, $+2\sqrt{6}V_r$, 0 and $+\sqrt{2}V_r$, to the first to fourth address lines in a set when the first column of the orthogonal matrix is the select vector.
- [0111]** 5. Both select and data voltages are applied to the corresponding electrodes simultaneously for a duration T, referred to as the select interval (T).
- [0112]** 6. Select vector and the corresponding data vector are rotated (either up or down) vertically by one position. Three select vectors can be obtained by three successive rotation of a select vector in (38). Hence, the total number of select vectors is 24 (6x4).
- [0113]** 7. The new select vector that is obtained by rotating a select vector in (38) is used to select either the same address lines or another set of address lines for a duration T as described in steps 3 and 4.
- [0114]** 8. A cycle is complete when all the set of address lines in the matrix display are selected with all the (24)

select vectors i.e. six basic vectors and the eighteen vectors derived by rotating them.

[0115] The display is refreshed continuously by repeating this cycle at a rate that is fast enough to avoid flicker and ensure RMS response. Scanning sequence described here ensures that all the address lines in the matrix display are selected with the five wavelets once in each cycle. Waveforms across the pixels will be DC free because the wavelets are DC free. Typical waveforms of the addressing technique are shown in FIG. 9. Number of time intervals to complete a cycle is about 6N. Analysis of this technique is presented in the next section.

Analysis for Slant Wavelet

[0116] RMS voltage across a pixel when the matrix display is scanned with waveforms corresponding to the orthogonal matrix in (38) is as follows:

$$V_{pixel(RMS)} = \sqrt{\frac{6 \sum_{k=0}^4 2^k (V_r^2 - 2 \cdot d_{k,i,j} V_r \cdot V_c + N \cdot V_c^2)}{6N}} \quad (43)$$

$$V_{ON(RMS)} = \sqrt{\frac{31(V_r^2 + 2V_r \cdot V_c + N \cdot V_c^2)}{N}} \quad (44)$$

$$V_{OFF(RMS)} = \sqrt{\frac{31(V_r^2 - 2V_r \cdot V_c + N \cdot V_c^2)}{N}} \quad (45)$$

[0117] Ratio of RMS voltage across the ON pixels to that across OFF pixels is called the selection ratio. It is a measure of the performance of the addressing technique and a high selection ratio is preferred to achieve a high contrast in the display. It is a maximum when:

$$\frac{V_r}{V_c} = \sqrt{N} \quad (46)$$

$$\text{Maximum selection ratio} = \sqrt{\frac{\sqrt{N} + 1}{\sqrt{N} - 1}} \quad (47)$$

[0118] It is the maximum selection ratio that is achievable by any addressing technique employed for driving the RMS responding passive matrix LCDs. A good contrast is obtained when the RMS voltage across the OFF pixels in the display are biased near the threshold voltage of the LCD. The voltage V_c is obtained by equating the voltage across OFF pixels to the threshold voltage ($V_{threshold}$) of the liquid crystal display.

$$V_{OFF} = \sqrt{\frac{31(2N - 2\sqrt{N})}{N}} \cdot V_c = V_{threshold} \quad (48)$$

$$\text{Hence, } V_c = \frac{V_{threshold}}{\sqrt{62 \left(1 - \frac{1}{\sqrt{N}}\right)}} \quad (49)$$

[0119] Supply voltage of the drive electronics is determined by the maximum swing in the addressing waveforms. Amplitude of the scanning waveforms increases and the data

waveforms decreases as the number of address lines that are multiplexed is increased in multi-line addressing techniques. Hence, the expression for the supply voltage when N is small is determined by the maximum swing in the data waveforms where as the supply voltage is determined by the maximum swing in the scanning waveforms when N is large.

[0120] Maximum amplitude of the data waveforms and scanning waveforms are as follows:

$$\text{Data voltage(max)} = (2\sqrt{6} + 4 + \sqrt{2}) V_c \quad (50)$$

$$\text{Scanning voltage(max)} = 2\sqrt{6}\sqrt{N} V_c \quad (51)$$

[0121] Hence, supply voltage of the drive electronics is as follows.

$$V_s = \begin{cases} (\sqrt{96} + 8 + \sqrt{8}) V_c & \forall N < 5 \\ \sqrt{96N} V_c & \forall N \geq 5 \end{cases} \quad (52)$$

[0122] Supply voltage for most practical values (N>5) is given in (53).

$$\text{Supply voltage}_{(N \geq 5)} = \frac{\sqrt{96N}}{\sqrt{62\left(1 - \frac{1}{\sqrt{N}}\right)}} V_{\text{threshold}} \quad (53)$$

[0123] A plot of the supply voltage for this range is shown in FIG. 10.

[0124] Analysis presented in this paper is independent of the scanning sequence, the order in which the scanning electrodes are selected with select vectors. There are 24! possible ways of selecting four address lines (a set) with the 24 select vectors. The (N/4) sets (of address lines) themselves can be chosen in any one of the (N/4)! ways. Although there are many possible ways of selecting the address lines, the RMS voltage across the pixels will be the same as long as the RC time constant of the drive circuit is small as compared to the select time T. Drive waveforms will get distorted (due to the 'ON' resistance of the drivers and the capacitance of the pixels) whenever there is a transition in the waveforms. Number of transitions in the addressing waveforms is determined by the scanning sequence. In case the RC time constant is large, then RMS voltages across the pixels will be less due to distortion in the waveforms. Number of transitions in the addressing waveforms also determines the power dissipated in the drivers and it is also preferable to have smaller amplitude of transitions to reduce the power consumption. Frequency spectrum across the pixels is also determined by the addressing sequence.

Hardware Complexity of the Drive Electronics for Slant Wavelet

A. Reducing Hardware Complexity of the Row Drivers

[0125] Number of non-zero elements in each column of the orthogonal matrix in (38) is intentionally restricted to just three to reduce the hardware complexity of the row drivers. Number of voltages in the scanning waveforms is just four at a given instant of time (out of the eleven possible values viz. +4, +2 $\sqrt{6}$, +2 $\sqrt{3}$, + $\sqrt{2}$, +1, 0, -2, -2 $\sqrt{2}$, -2 $\sqrt{3}$, -2 $\sqrt{6}$ and -4. Hence it

is adequate to have the following elements in each stage (corresponding to one output) of the row driver (111) integrated circuit (IC):

[0126] 1. A stage of the two-bit shift register to enable serial transfer of data in to the driver IC.

[0127] 2. A two-bit latch to hold the data stable during a select time (and allow serial transfer of the data in the shift register) so that the desired voltage can be applied to the address lines. One of the four voltages that correspond to 0 in the orthogonal matrix is also the non-select voltage.

[0128] 3. A 4:1 analog multiplexer to select one of the four voltages on the internal bus of the driver IC. Select input of the multiplexer is the output of the two-bit latch of same stage.

[0129] Two 4:1 analog multiplexers and a 2:1 analog multiplexer are provided to reduce the hardware complexity of the drivers. These row voltage selectors (110) are common to all stages of the row drivers. They connect the three non-zero select voltages to the voltage bus in the row drivers and they may be located outside the data drivers ICs because multiple number of driver ICs may be used in the displays. A block diagram of the row driver circuit that can be used to scan the display is shown in FIG. 11. Hardware complexity of the shift register, latch and multiplexer is reduced by 50%, 50% and 64% respectively as compared to using a driver that is capable of selecting one out of nine voltages using 4-bit shift register, 4-bit latches and 11:1 analog multiplexers in the driver IC. Addition of three multiplexers (as shown in FIG. 11) does not increase the hardware complexity of the drive circuit significantly because the number of rows (N) in the matrix display is usually large.

B. Reducing Hardware Complexity of the Column Drivers

[0130] Number of voltages in the column (data) waveforms is 24 and a 5-bit shift register, 5-bit latch and 24:1 analog multiplexers may be used to generate the column (data) waveforms. However, just four or eight voltages are necessary at a given instant of time depending on the number of non-zero elements (one or two) in the select vector. Hardware complexity of the column drivers can be reduced by using column voltage selector (120) with eight 4:1 analog multiplexers that are common to all the data drivers along with column driver (121) ICs (with 3-bit shift register, 3-bit latches and 8:1 analog multiplexers in each stage) that are capable of applying any one of the eight voltages depending on 3-bits of data. Hardware complexity is reduced by 40%, 40% and 66% for the shift register, latches and analog multiplexers respectively in the column drivers. The increase in hardware complexity due to the eight 4:1 multiplexers is not significant because the number of columns (data electrodes) in a display is usually large. A block diagram of the column driver circuit is shown in FIG. 12.

C. Generation of Data for the Column Driver

[0131] Although the column voltage is proportional to the dot product of the select vector and the data vector, it is not necessary to compute this dot product repeatedly while scanning the display. Result of the dot product of a select vector with any data vector is just one of the eight or four values for the following reasons.

[0132] 1. Number of unique select vectors is limited, the rotated versions of a select vector and the select vectors

whose elements differ only in sign and not in magnitude are not considered to be unique. For example, the vectors in the following equations are not unique.

$$\begin{bmatrix} -4 \\ 0 \\ +2\sqrt{3} \\ +1 \end{bmatrix}; \begin{bmatrix} +1 \\ -4 \\ 0 \\ +2\sqrt{3} \end{bmatrix}; \begin{bmatrix} -4 \\ 0 \\ -2\sqrt{3} \\ +1 \end{bmatrix}; \begin{bmatrix} -2\sqrt{3} \\ +1 \\ -4 \\ 0 \end{bmatrix} \dots \text{etc.} \quad (54)$$

[0133] 2. Number of non-zero elements in the select vectors is either three or two reduce the hardware complexity of the column (data) drivers.

[0134] 3. Elements of the data vectors are either +1 or -1 because they correspond to just one bit of the data.

[0135] Number of unique select vectors in the orthogonal matrix of (38) is just four. Here again it is enough to compute these values during design of the voltage level generator (VLG). Voltages from the VLG are inputs to the eight 4:1 analog multiplexers that are common to all column driver ICs. Outputs of the multiplexers are connected to the voltage bus in the column drivers. These eight multiplexers select voltages corresponding to one of the four unique select vectors. The data bits corresponding to the non-zero elements are shifted in to column driver to select one of the eight voltages in the bus. Hence it is not necessary to compute the dot product and complex wavelets (if they are advantageous for other reasons) could be used without increasing the hardware complexity of the drive electronics as compared to using integer wavelets. Controller is also simple when the number of address lines is an integer power of two as explained in integer wavelet.

D. Implementation

[0136] The technique is demonstrated with a 32x32 matrix twisted nematic (TN) liquid crystal display and the photographs of the prototype are shown in FIG. 13. We have used drivers that are capable of applying one of the eight voltages with a 8:1 multiplexer as both row and column drivers although it is adequate to have drivers that are capable of applying just four levels as row drivers. A controller for refreshing the display was implemented in a CPLD (XCR 3256 XL) using 106 macro-cells, 243 product terms and 68 registers. Typical row and column waveforms are shown in FIG. 14 and the waveform across a pixel is shown in 15. Response times were measured when the pixels are switched from a gray to another and the results are shown in Table-IV. The following information is useful for comparing the response times of the display under multiplexed (Table-IV) and non-multiplexed conditions. The switch ON and switch OFF times of a cell of 3.9 μm and filled with the liquid crystal mixture RO-TN-403 was 30 and 12 ms respectively. Voltage across the pixel was switched to 1.33 volts (threshold voltage of the display) and 1.58 volts (voltage across an ON pixel when the number of lines multiplexed is 32) alternately by applying square waveforms.

Comparison with Other Techniques

[0137] Amplitude modulation needs 62 voltages in the column waveforms and 3 voltages in the row waveforms to display 32 gray shades. It takes 4N time intervals (including DC free operation) are necessary to complete a cycle when the gray shades are displayed using amplitude modulation technique [1]. A similar technique called the pulse height

modulation technique also needs a large number of voltages in the data waveforms [6]. It is more appropriate to compare the wavelet-based techniques with the successive approximation techniques [2], [8] because both these techniques are based on modulating the energy delivered to the pixels using several time intervals. A comparison of the wavelet-based technique with successive approximation techniques is given in Table-V. Although the number of voltages in the waveforms is more when slant wavelets are used, the hardware complexity of drive electronics can be reduced as discussed in this paper.

CONCLUSION

[0138] We have shown that the number of time intervals to complete a cycle can be reduced when the number of gray shades is 16, 32, etc. by using slant wavelets. We have also shown that hardware complexity of the drive electronics does not increase when complex-non-integer wavelets are used to scan the display as compared to the integer wavelets. The techniques for eliminating repeated computation of the orthogonal transform of the data and the reduction of hardware complexity can be applied even when other orthogonal wavelets are used for scanning the display instead of just Harr and slant. Other wavelets that could be used are Daubechies wavelets and Coiflet wavelets. Given below are few examples of orthogonal wavelets that could be used, however the examples given here should not be consider as the limitation of the instant invention.

8 Shades: Non-integer

$$\begin{bmatrix} +\sqrt{2} & +\sqrt{2} & -\sqrt{2} & -\sqrt{2} \\ +\sqrt{2} & -\sqrt{2} & 0 & 0 \\ 0 & 0 & +1 & -1 \end{bmatrix}$$

16 Shades: Non-integer (Non-DC free)

$$\begin{bmatrix} +2 & +2 & +2 & +2 \\ +\sqrt{2} & +\sqrt{2} & -\sqrt{2} & -\sqrt{2} \\ +\sqrt{2} & -\sqrt{2} & 0 & 0 \\ 0 & 0 & +1 & -1 \end{bmatrix}$$

32 Shades: Integer

$$\begin{bmatrix} +2 & +2 & +2 & +2 & -2 & -2 & -2 & -2 \\ +2 & +2 & -2 & -2 & 0 & 0 & 0 & 0 \\ 0 & 0 & 0 & 0 & +1 & +1 & -1 & -1 \\ +2 & -2 & 0 & 0 & 0 & 0 & 0 & 0 \\ 0 & 0 & +1 & -1 & 0 & 0 & 0 & 0 \end{bmatrix}$$

64 Shades: Non-integer

$$\begin{bmatrix} +2\sqrt{2} & +2\sqrt{2} & +2\sqrt{2} & +2\sqrt{2} & -2\sqrt{2} & -2\sqrt{2} & -2\sqrt{2} & -2\sqrt{2} \\ +2 & +2 & -2 & -2 & +2 & +2 & -2 & -2 \\ +2\sqrt{2} & -2\sqrt{2} & 0 & 0 & 0 & 0 & 0 & 0 \\ 0 & 0 & +2 & -2 & 0 & 0 & 0 & 0 \\ 0 & 0 & 0 & 0 & +\sqrt{2} & -\sqrt{2} & 0 & 0 \\ 0 & 0 & 0 & 0 & 0 & 0 & +1 & -1 \end{bmatrix}$$

-continued

128 Shades: Non-integer

$$\begin{bmatrix} +4 & +4 & +4 & +4 & -4 & -4 & -4 & -4 \\ +4 & +4 & -4 & -4 & 0 & 0 & 0 & 0 \\ 0 & 0 & 0 & 0 & +2\sqrt{2} & +2\sqrt{2} & -2\sqrt{2} & -2\sqrt{2} \\ +2\sqrt{2} & -2\sqrt{2} & 0 & 0 & 0 & 0 & 0 & 0 \\ 0 & 0 & +2 & -2 & 0 & 0 & 0 & 0 \\ 0 & 0 & 0 & 0 & +\sqrt{2} & -\sqrt{2} & 0 & 0 \\ 0 & 0 & 0 & 0 & 0 & 0 & +1 & -1 \end{bmatrix}$$

TABLE IV

RESPONSE TIMES (IN MILLISECONDS) WHEN PIXELS ARE SWITCHED TO DIFFERENT GRAY SHADES USING WAVELETS.

Gray shade value	0	3	7	11	15	19	23	27	31 (ON)
0 (OFF)	—	72	65	60	55	52	50	44	40
3	75	—	68	70	56	61	58	55	52
7	70	78	—	72	57	54	52	50	50
11	61	75	75	—	73	58	55	48	40
15	60	73	64	80	—	78	63	55	53
19	58	75	60	65	90	—	65	54	51
23	50	70	58	66	75	87	—	60	55
27	45	60	56	60	58	73	72	—	44
31 (ON)	44	65	54	52	55	65	69	59	—

TABLE V

COMPARISON OF THE GRAY SHADE TECHNIQUES (32 GRAY SHADES)

Parameter	Successive approximation technique (Line-by-line) [8]	Successive approximation (MLA) 4 lines in a subgroup [2]	Technique Based on Integer Haar Wavelets	Technique based on modified Slant Wavelets
Number of time intervals for displaying 32 gray shades	10N	10N	8N	6N
Number of voltages in scanning waveforms	11 (16 for IAPT)	11	5	11
Number of voltages in the data waveforms	10 (16 for IAPT)	15	11	24

1. A system to drive display matrix, comprising:
 - a. a voltage level generator to provide predetermined voltages,
 - b. a row voltage selector to select a group of voltages from the voltage level generator depending on select vector as input voltages to the row drivers,
 - c. a column voltage selector to select a group of voltages from the voltage level generator depending on the select vector as input voltages to the column drivers, and
 - d. a controller to generate control signals to scan the display as dictated by addressing technique.

2. The system as claimed in claim 1 step b, wherein the row drivers select a final voltage from the group of input voltages to drive rows of the display.

3. The system as claimed in claim 1 step c, wherein the column drivers select a final voltage from the group of input voltages to drive columns of the display.

4. The system as claimed in claim 2, wherein the row and column driver comprises of one stage of shift registers and latches to select the final voltage.

5. The system as claimed in claim 1 wherein the voltage selectors are preferably analog multiplexers.

6. The system as claimed in claim 1, wherein the row voltage selectors and the column voltage selectors are common to the entire row drivers and column drivers respectively.

7. The system as claimed in claim 1, wherein the controller sends control signals to the voltage selectors and the drivers to scan the display.

8. The system as claimed in claim 1, wherein the controller comprises a binary counter to generate address of pixels.

9. A method to reduce drivers hardware for displaying gray shades, said method comprises steps of:

- a. choosing wavelets based on gray shade data bits to form orthogonal matrix wherein each column in the matrix is select vector and the number of rows of the orthogonal matrix is not necessarily equal to the number of gray shade data bits,
- b. grouping of scanning electrodes based on number of rows in the matrix and thereafter constructing data matrix by selecting the gray shade data bits corresponding to elements of the orthogonal matrix wherein each column of the data matrix is a data vector,

- c. generating voltages for data electrodes and thereby applying the select vector and the corresponding voltages for the data electrodes in the group, and
- d. rotating rows of the orthogonal matrix and the data matrix once, followed by repeating step 'c' until every row of the orthogonal matrix and the data matrix takes position of first row in the respective matrix for displaying gray shades.

10. The method as claimed in claim 9, wherein amplitude of the wavelets is an integer.

11. The method as claimed in claim 9, wherein energy of the wavelets is equal to an integer power of two.

12. The method as claimed in claim 9, wherein the energy of the wavelet is chosen to correspond uniquely to weight of the gray shade data bit.

13. The method as claimed in claim 9, wherein the wavelets are DC free to ensure long life of display.

14. The method as claimed in claim 9, wherein the wavelet is selected from the group comprising Haar wavelet, slant wavelet and other orthogonal wavelets

15. The method as claimed in claim 9, wherein the voltage for data electrodes is generated using dot product of the select vector and the data vector.

16. The method as claimed in claim 9, wherein the voltage for the data electrodes is generated for the entire data electrodes and the entire groups.

* * * * *