

C H A P T E R I V

ELECTROMECHANICAL COUPLING IN CHOLESTERIC LIQUID CRYSTALS

4.1 INTRODUCTION

The cholesteric liquid crystal is a chiral system consisting of orientationally ordered optically active molecules. The director twists about an orthogonal axis to form a helix (Fig. 1.1b in Chapter I) with a pitch 'P' in the range of a few microns.

In parity conserving systems the Curie (or Von Neumann) principle (for e.g., Boccara 1981) requires that the symmetry of physical effects must be contained in the causes which give rise to them. But in chiral systems, which lack mirror symmetry the principle predicts novel types of couplings between fluxes and forces (Pomeau 1971). In cholesteric liquid crystals the cooperative nature of the chiral interactions may be expected to give rise to a macroscopic manifestation of the same resulting in unusual effects which are clearly observable. One such effect - the thermomechanical coupling was observed by Lehmann in 1900. He found that in small cholesteric drops taken between two glass surfaces a thermal gradient along the helical axis gives rise to a continuous rotation of the structure about that axis (see Fig. 4.1). The thermomechanical effect results in an angular momentum density of the director even though the applied force has the character of a polar vector.

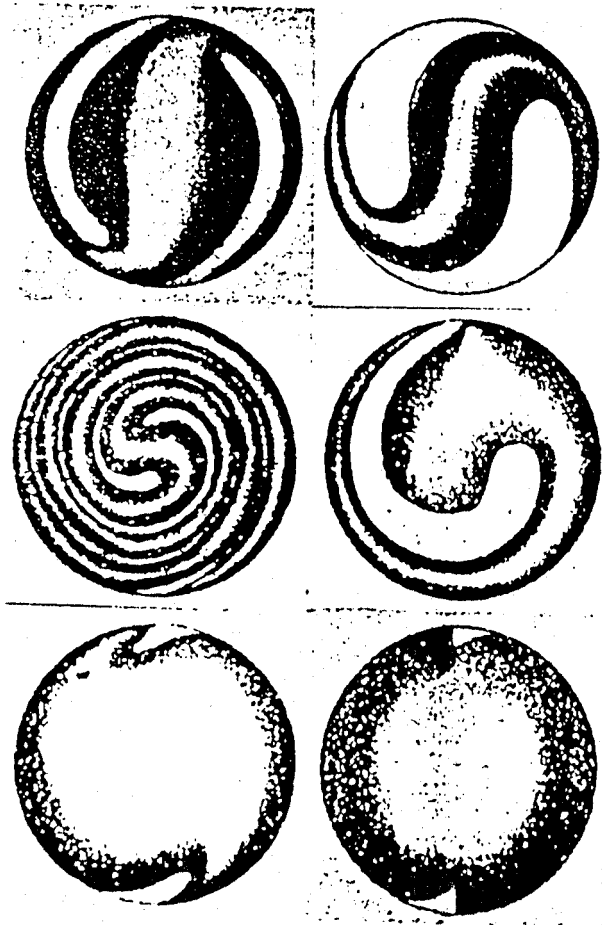

Figure 4.1

Lehmann's diagrams illustrating the rotation phenomenon in open cholesteric droplets heated from below (From Chandrasekhar 1977).

Leslie (1968, 1979) and others have worked out detailed hydrodynamic theories of cholesterics and obtained solutions corresponding to the Lehmann effect. de Gennes (1975) has pointed out that any transport current should in principle give rise to a similar effect. We have used his formulation in our discussion.

4.2 HYDRODYNAMICS OF CHOLESTERIC

Consider a transport current density which can be an electric current density, a heat current density or a diffusion current density. The conjugate field associated with this current is \vec{E} . For the three cases mentioned above, $\vec{E} = -\nabla V$ (where V = electrical potential), $\vec{E} = -\frac{\nabla T}{T}$ and $\vec{E} = -\nabla \mu$ (where μ is the chemical potential of the diffusing species) respectively. The entropy source including flow, rotation of the director and transport is given by

$$T\dot{S} = A : \sigma' + \vec{h} \cdot \dot{\vec{N}} + \vec{J} \cdot \vec{E} \quad (4.1)$$

The quantities A - the symmetric part of the velocity gradient tensor, σ' - the complete viscous stress tensor, \vec{h} - the molecular field and $\dot{\vec{N}}$ - the rate of change of the director with respect to the background fluid are as defined in Chapter I. A , $\dot{\vec{N}}$ and \vec{E} are chosen as fluxes while σ' , \vec{h} and \vec{J} are the conjugate forces.

The phenomenological equations between the fluxes and forces can then be written. Taking into account the Onsager reciprocal relations also, we can write

$$\sigma'_{\alpha\beta} = \sigma_{\alpha\beta}^N + \mu_1 n_{\alpha} (\vec{E} \times \vec{n})_{\beta} + \mu_2 n_{\beta} (\vec{E} \times \vec{n})_{\alpha} \quad (4.2)$$

$$\vec{h} = h^N + v\vec{n} \times \vec{E} \quad (4.3)$$

$$\begin{aligned} \vec{J} = & \sigma_{\perp} \vec{E} + (\sigma_{\parallel} - \sigma_{\perp}) (\vec{n} \cdot \vec{E}) \vec{n} + v\vec{n} \times \vec{N} \\ & - (\mu_1 + \mu_2) \vec{n} \times (A : \vec{n}) \end{aligned} \quad (4.4)$$

here $\sigma_{\alpha\beta}^N$ and h^N denote the contributions from the hydrodynamics of nematics (Chapter I - see Eqns. 1.23 & 1.24). σ_{\parallel} and σ_{\perp} are the conductivities, μ_1 , μ_2 and v are the new phenomenological coefficients related by $\mu_1 - \mu_2 = v$.

All the terms in eqns. (4.2) - (4.4) which are associated with the coupling coefficients μ_1 , μ_2 and v change sign when the coordinate system is reflected in a mirror. Then the cross coupling coefficients must also change sign, i.e., they can only have a non-zero value for chiral systems. Since the handedness of the helix changes sign under a mirror reflection the coupling coefficients must be proportional to q , where $q = 2\pi/P$ is the wavevector of the helix. Its sign is taken to be positive (negative) for right (left) handed helix. This would of course mean that in a nematic or in a compensated cholesteric with $q = 0$ the cross coupling does not exist.

The Lehmann rotation is a consequence of the cross coupling between thermal and mechanical effects.

We now consider in general the effect of a transport current which should give rise to a similar effect.

Let us consider a cholesteric sample with planar texture and let a relative thermal gradient or an electric field be applied parallel to the helical axis and we assume that there is no hydrodynamic flow, i.e., $A=0$. The angle $\phi(z)$ between the director and a fixed axis x can be obtained from the torque balance equation.

Let us first consider the viscous torque

$$\Gamma_z^{\text{viscous}} = \sigma'_{yx} - \sigma'_{xy}$$

Substituting for the σ 's from eqns. (4.2) when $A=0$, we have

$$\begin{aligned} \Gamma_z^{\text{viscous}} &= \alpha_2 n_y \dot{n}_x + \alpha_3 n_x \dot{n}_y - \alpha_2 n_x \dot{n}_y - \alpha_3 n_y \dot{n}_x \\ &+ \mu_1 n_y (-n_y E_z) + \mu_2 n_x (n_x E_z) - \mu_1 n_x (n_x E_z) - \mu_2 n_y (-n_y E_z) \\ &= (a_2 - a_3) (n_y \dot{n}_x - n_x \dot{n}_y) - \nu n_y^2 E_z - \nu n_x^2 E_z \end{aligned} \quad (4.5)$$

Now $n_x = \cos \phi$ and $n_y = \sin \phi$

Therefore

$$\begin{aligned} \Gamma_z^{\text{viscous}} &= (\alpha_2 - \alpha_3) (-d\phi/dt) - \nu E_z \\ &= \gamma_1 \frac{d\phi}{dt} - \nu E_z \end{aligned} \quad (4.6)$$

as

$$\alpha_3 - \alpha_2 = \gamma_1 \quad \text{and} \quad \mu_1 - \mu_2 = \nu. \quad (4.7)$$

The elastic torque $\Gamma_z^{\text{elastic}}$ is given by

$$\Gamma_z^{\text{elastic}} = n_x h_y - n_y h_x \quad (4.8)$$

h_x and h_y can be obtained from the expression for the free energy density

$$\begin{aligned} F_d &= \frac{K_{22}}{2} [\vec{n} \cdot \text{curl } \vec{n} + q_0]^2 \\ &= \frac{K_{22}}{2} \left[n_y \frac{\partial n_x}{\partial z} - n_x \frac{\partial n_y}{\partial z} + q_0 \right]^2 \end{aligned} \quad (4.9)$$

We then have

$$\begin{aligned} h_x &= -\frac{\partial F_d}{\partial n_x} + \frac{\partial}{\partial z} \left[\frac{\partial F_d}{\partial (\partial n_x / \partial z)} \right] \\ \text{and} \\ h_y &= -\frac{\partial F_d}{\partial n_y} + \frac{\partial}{\partial z} \left[\frac{\partial F_d}{\partial (\partial n_y / \partial z)} \right] \end{aligned} \quad (4.10)$$

Therefore

$$\Gamma_z^{\text{elastic}} = -K_{22} \left[n_y \frac{\partial^2 n_x}{\partial z^2} - n_x \frac{\partial^2 n_y}{\partial z^2} \right] \quad (4.11)$$

Again substituting $n_x = \cos \phi$ and $n_y = \sin \phi$

$$\Gamma_z^{\text{elastic}} = K_{22} (\partial^2 \phi / \partial z^2) \quad (4.12)$$

Equating the elastic and viscous torques,

$$\gamma_1 \frac{d\phi}{dt} - \nu E_z = K_{22} (\partial^2 \phi / \partial z^2)$$

or

$$\gamma_1 \frac{d\phi}{dt} = K_{22} (\partial^2 \phi / \partial z^2) + \nu E_z \quad (4.13)$$

where E_{\perp} is the component of \vec{E} normal to \vec{n} , i.e., E_z , and ν is the thermo- (or electro-) mechanical coupling coefficient. Eqn. (4.13) can be integrated using proper boundary conditions. If the anchoring energy for azimuthal orientation is zero $\frac{\partial \phi}{\partial z} = q_0 = 2\pi/P$ at both the boundaries and hence a constant in the sample. The solution is then of the form $\phi = q_0 z + \frac{\nu E t}{\gamma_1} + c$, where c is a constant of integration. The director rotates with a constant angular velocity given by $\nu E / \gamma_1$. The angular velocity is proportional to the relative temperature gradient or electric field \vec{E} and the sense of rotation should change when \vec{E} is reversed. Also the sense of rotation should depend on the handedness of the helix, i.e., the coupling coefficient is proportional to q .

Leslie concluded that the rotation phenomenon observed by Lehmann is a consequence of the cross coupling term ν .

Lubensky (1972, 1973) developed a hydrodynamic theory of cholesterics valid for spatial distortions whose wavelength is $\gg P$ the pitch. Again he concluded that the symmetry of such systems allows for a thermomechanical effect which couples the phase of the layers with a temperature gradient. For a cholesteric, the phase is determined by the azimuthal angle of the director and one again gets solutions corresponding to the Lehmann rotation. He also recognised that such a rotation would crucially depend on the boundary conditions (Lubensky 1973). Martin et al. (1972) developed a general theory of hydrodynamics of layered systems

applicable to cholesterics also and got similar solutions. The Lubensky formulation is specifically meant for cholesterics.

The Onsager relations were not used in the theory of Leslie. Prost (1972) used these relations in the Leslie theory and in this case the thermo (or electro) mechanical coefficients are found not to contribute to the entropy production in an undistorted cholesteric. This can be shown by using Eqns. (4.2 - 4.4) which already incorporate the Onsager relations.

Let us consider the terms associated with the thermo (or electro) mechanical parts in the expression for the entropy production, i.e., in Eqns. (4.1) and (4.2) - (4.4)

$$\begin{aligned} T\dot{S} &= A : [\mu_1 n_\alpha (E \times n)_\beta + \mu_2 n_\beta (E \times n)_\alpha] \\ &\quad + \nu \vec{n} \times \vec{E} \cdot \vec{N} + \nu \vec{n} \times \vec{N} \cdot \vec{E} \\ &\quad - (\mu_1 + \mu_2) [\vec{n} \times (A : \vec{n}) \cdot \vec{E}] \end{aligned} \quad (4.14)$$

$$\begin{aligned} &= (\mu_1 + \mu_2) [\vec{n} \times (A : \vec{n}) \cdot \vec{E}] + \nu \vec{n} \times \vec{E} \cdot \vec{N} + \nu \vec{n} \times \vec{N} \cdot \vec{E} \\ &\quad - (\mu_1 + \mu_2) [\vec{n} \times (A : \vec{n}) \cdot \vec{E}] = 0 \end{aligned} \quad (4.15)$$

Thus we see that the cross coupling coefficients have a reactive and not a dissipative character. As mentioned earlier, in the original formulation of Leslie, the Onsager relations have not been used. The thermomechanical coefficients would then contribute to the entropy production. The 'v' coefficient in the model develo-

ped by Lubensky (1973) is also seen to contribute to the entropy production.

An experimental determination of the thermomechanical coupling coefficient is of obvious interest, but to our knowledge the Lehmann experiment has never been reproduced though there have been several attempts to do the same. For example, an attempt in our own laboratory to reproduce the Lehmann experiment did not succeed (Chandrasekhar and Suresh). The reason for this negative result is that in none of these attempts, the anchoring energy at the boundary surfaces was sufficiently weak. We can indeed make an estimate of the allowed upper limit of the anchoring energy, for the rotation to be possible.

To simplify the argument let us assume that the upper surface at $z=d$ is free and has zero anchoring energy. The lower surface at $z=0$ which is resting on the glass plate has an anchoring energy given by $W/2 \sin^2 \phi_0$, where ϕ_0 is the angle made by the director with respect to the easy axis. The restoring torque at $z=0$ due to this anchoring energy is $W \sin \phi_0 \cos \phi_0$, which has a maximum value at $\phi_0 = \pi/4$. We can then assume that the surface anchoring can be overcome if the angle ϕ_0 exceeds $\pi/4$ due to the action of the thermomechanical coupling and then the rotation becomes possible, though not freely.

Let us now estimate the maximum allowed value of W by treat-

ing the problem in the static limit. The surface torque balance is given by

$$W \sin \phi_0 \cos \phi_0 = K_{22} [(\partial\phi/\partial z)_0 + q_0] \quad (4.16)$$

and the bulk torquebalance equation in the static limit is

$$K_{22} (\partial^2\phi/\partial z^2) = \nu E \quad (4.17)$$

we have a free surface at $z = d$, hence $[\partial\phi/\partial z]_{z=d} = q_0$. The solution is then

$$\phi = (\nu E/2K_{22})z^2 + qz + \phi_0 \quad (4.18)$$

where

$$q = [q_0 - (\nu E/K_{22})d].$$

Therefore using this, at $z = 0$, we get

$$W = -\frac{\nu E d}{\sin \phi_0 \cos \phi_0} \quad (4.19)$$

As ν has the dimension of an energy/unit area and as we noted earlier $\gamma \propto q_0$, a dimensional estimate for ν is (de Gennes 1975) $\nu = xK_{22}q_0$, where x can be assumed to be ≈ 1 . This gives $\nu = 10^{-3}$ cgs units. If $\phi_0 = \pi/4$ we get $W \approx 10^{-4}$ cgs units. This is equal to an extrapolation length $L = K_{22}/W \approx 10 \mu\text{m}$. For the drops to rotate the anchoring energy must be lower than this. To our knowledge a measurement of the azimuthal anchoring energy is not available,

but for the polar angle θ , a silicon monoxide coated surface gives an extrapolation length of only $\sim 0.1 \mu\text{m}$ (Berreman 1972, 1973; Wolff et al. 1973) and it is not easy to obtain surfaces which give homogeneous alignment with weak anchoring. We could hence conclude that the azimuthal anchoring with an extrapolation length $>10 \mu\text{m}$ is also difficult to achieve on a solid surface. If the cholesteric is in contact with solid surfaces on both sides, we can expect that the anchoring energy must be much weaker than the above estimate to obtain any rotation of the cholesteric. We believe that in none of the earlier attempts to reproduce Lehmann rotation the anchoring was sufficiently weak for the structure to rotate.

There have been several papers suggesting alternate experimental geometries to measure the coupling coefficient. We now give a brief outline of these.

Prost (1972) suggested that a planar cholesteric sample subjected to a rotating magnetic field acting in a plane perpendicular to the helical axis would produce a rotation of the director and result in a temperature gradient along the helical axis. However, for practical rotational speeds, the estimated temperature gradient is only -10^{-6} deg/cm.

Prost (1972) also pointed out that a cholesteric sample flowing in a capillary tube with the helical axis along the tube

would give rise to a rotation of the director, due to the permeation process (Helfrich 1969). The rotation again results in a temperature gradient which is in principle measurable. Ranganath (1983) has pointed out the possibility of the reverse effect: a temperature gradient along the cholesteric sample in a capillary results in a permeation flow. To our knowledge, such experiments have not been tried.

Jayaram et al. (1983) have suggested that a temperature gradient normal to the helical axis imposed on a planar aligned sample of a cholesteric liquid crystal induces lateral flows and in turn gives rise to a distortion of the director field due to the effect of both the thermomechanical coefficients. They propose that the distortion can be detected by optical studies.

The only claim of an experimental determination of the thermomechanical coefficient is due to Eber and Janossy (1982, 1984). They have used a mixture of two liquid crystals which shows a compensation temperature T_c . The medium has a left-handed helical structure below T_c and the pitch increases to become w and reverses sign at T_c , i.e., the structure becomes right handed above T_c . In the experiment, a homeotropically aligned sample near T_c was subjected to a transverse temperature gradient (dT/dX). This results in a tilting of the director. In a linear approximation the tilt angle is given by

$$\theta(z) = \frac{\lambda_{\text{eff}}}{K_{33}} \frac{L^2 - 4z^2}{8} \frac{dT}{dX} \quad (4.20)$$

where L is the thickness of the sample, K_{33} is the bend elastic constant. Assuming that the thermomechanical coefficients are independent of the magnitude or sign of q ($= 2\pi/P$) Eber and Janossy derived

$$\lambda_{\text{eff}} = \lambda_3 + K_{22} dq/dT \quad (4.21)$$

where the coefficient $\lambda_3 = \nu/T$. K_{22} is the twist elastic constant. Eber and Janossy have measured the deformation by an optical technique and estimated $K_{22} dq/dT$ by an independent measurement. Eqns. (4.20) and (4.21) can then be used to calculate λ_3 . However the cross coupling term which arises due to the helical arrangement of the cholesteric should vanish when $q=0$, i.e., at the compensation temperature. (Indeed, the theory requires that $\lambda_3 \propto q$ and should change sign with that of q .) Since Eber and Janossy assumed that λ_3 is independent of q in deriving Eqns. (4.20) and (4.21), they assume in effect that the thermomechanical coefficient is molecular rather than structural in origin (and in that case λ_3 can be expected to be very small).

Further, in analysing the data they have used the temperature at which the homeotropic texture goes over to the fingerprint texture to estimate dq/dT . In a recent letter, Pleiner and Brand (1987) have pointed out that the above method of measuring dq/dT

cannot be very accurate since the derivation of the formula for estimating dq/dT does not take into account the defects present in the fingerprint texture. Indeed the estimate of dq/dT by Pleiner and Brand would make the value of $v \approx 0$. They have also pointed out that a non-linear hydrodynamic theory is necessary to produce any thermomechanical effects in a compensated cholesteric. Thus the thermomechanical coefficient extracted by Eber and Janossy from their experiment is subject to doubts, and in any case it is not of structural origin.

Janossy (1981a & b) has made another interesting observation. He took a planar aligned cholesteric sample between two discs, and slowly rotated one with reference to the other. He then observed that small ($1 - 2 \mu\text{m}$ thick) dust particles drifted radially. For one sense of rotation, the particles concentrate near the axis of rotation, while for the opposite sense the particles drift away from the axis. He has interpreted the result in terms of a 'diffusomechanical coupling' in analogy with one of the thermomechanical coupling coefficients. However the shear flow induces a secondary flow of the material with the same characteristic features (Chandrasekhar et al. 1980) and the separation between the two is not clear. Careful experiments are necessary for a detailed analysis to separate the two effects.

In view of all these studies we see that the **Lehmann** experiment seems to be the most convincing demonstration of the cross

coupling coefficient v . It could also be used to check the dependence of the sense of rotation on the sign of E and of q for a given system.

We thus attempted to reproduce the Lehmann experiment, so that a measurement of the coupling coefficient could be made. The first task is to obtain flat cholesteric drops whose structure can rotate freely, i.e., the azimuthal anchoring energy at the surface of the drops must be zero. Therefore we see that cholesteric drops which are in contact with glass plates are not suitable for observing the Lehmann rotation phenomenon. On the other hand, one can expect that the azimuthal anchoring energy at the cholesteric-isotropic interface to be essentially zero. With this idea in mind we tried to sandwich cholesteric drops between two glass plates coated with various liquids like glycerine, ethylene glycol, diethylene glycol, nujol and water. But in all the cases this resulted only in spherical drops which do not have a suitable geometry. We found that a convenient method of getting the required type of drops was to dissolve in the cholesteric a small quantity of Lixon by weight, which is a non-mesomorphic epoxy compound. This results in a lowering of the cholesteric-isotropic transition temperature, and a broad two phase region. Moreover, one can form cholesteric drops which no longer have a spherical shape, but have a flattened appearance. More interestingly, they are surrounded by the isotropic phase on all sides. The reason for this configuration is that the epoxy compound has a strong affinity for

glass, i.e., it wets the glass much more efficiently than the cholesteric compound. The cholesteric phase has a lower concentration of the epoxy compound than the isotropic phase, which would hence prefer to be close to the glass plates. We can also note that the interfacial tension between the cholesteric and its own isotropic phase is likely to be $<10^{-3}$ dyne/cm (see for e.g., Faetti and Palleschi 1984) and hence the energy required to change the shape of the drop from the spherical shape is negligible. Further, the relative difference in density between the cholesteric and its own isotropic phase is also very small ($\sim 10^{-3}$) which enables the cholesteric drop to be surrounded by the isotropic phase on all sides. This results in the configuration shown in Fig. 4.2. In thin cells, with the glass plates separated by $\approx 8 \mu\text{m}$, we could easily form cholesteric drops with a lateral diameter of 20–50 μm using this technique. It is clear that the gap between the plates is too small for having a steady temperature gradient between them. However, as mentioned earlier, cross couplings can be expected for any transport current. It is extremely convenient to apply a DC electric field to such thin cells. Hence we chose to look for the electromechanical rather than the thermomechanical coupling.

4.3 ELECTROMECHANICAL EFFECT

If ν_E is the relevant coupling coefficient we can write on the basis of dimensional arguments

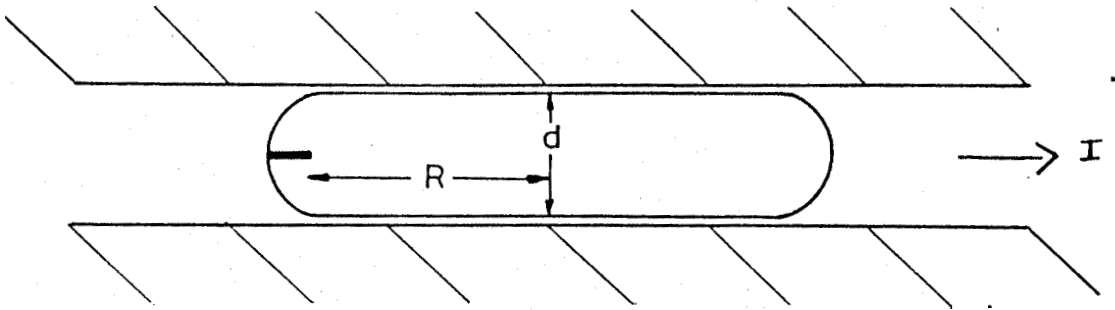

Figure 4.2

Vertical cross section of the flattened
cholesteric droplet surrounded by the I phase
between two glass plates.

$$v_E = nK_{22}q/V$$

where n is a small number ~ 1 and V is a characteristic voltage of the material. Identifying it with the redox potential of the mesogen $V \sim 1$ volt = $1/300$ e.s.u. and using $K_{22} \sim 10^{-7}$ dyne we get $|v_E/q| \sim 3 \times 10^{-5}$ cgs units. However, we must note that the director also couples to an external electric field through the dielectric anisotropy. Since the field has to be applied along the helical axis in the present experiment, we have chosen materials with negative dielectric anisotropy to avoid change in the orientation of the director due to this coupling. We made a binary mixture of ethoxy-phenyl-trans-butyl cyclohexyl carboxylate (EPBC) and methoxy-phenyl-trans-pentyl cyclohexyl carboxylate (MPPC) in the ratio of 18:82 weight % to get a room temperature nematic with a dielectric anisotropy ~ -1 . However the negative material can exhibit electrohydrodynamic instabilities under the action of a DC field beyond a threshold voltage (Helfrich 1969). We checked that the material used by us did not exhibit such instabilities up to about 8 volts. By dissolving a small percentage of Lixon, we could get a nematic-isotropic two phase region at room temperature. The nematic drops had the bipolar configuration (Dubois-Violette and Parodi 1969, Candau 1973) characteristic of a tangential boundary condition at the interface. In order to get cholesteric drops, we added suitable chiral compounds to the mixture. The left-handed helical arrangement with a pitch $\sim 5 \mu\text{m}$ (as measured

using a fingerprint texture exhibited by a thin sample) was obtained by dissolving 5% by weight of cholesteryl chloride in the sample (System I). Similarly dissolving 10% by weight of methyl butyl benzoyloxy heptyloxy cinnamate yielded a right handed helical arrangement with the same pitch (system II). The structural formulae and transition temperatures of the compounds are given in Fig. 4.3. The handedness of the helical arrangement was determined using a wedge-shaped sample of the chiralised material (without Lixon). The relative movement of the dark brushes near the edge of the wedge in relation to that of the analyser can then be used to find the sense of the helix.

4.4 STRUCTURE OF THE CHOLESTERIC DROP

Spherical cholesteric drops were obtained in thick cells ($-100 \mu\text{m}$) when the liquid crystal sample was emulsified with glycerine. These had the characteristic radial X line of strength +2. Such a pattern was first studied by Robinson and Ward (1956). Pryce and Frank have given a model (quoted by Robinson et al. 1958) to explain this configuration. If we consider the spherical surface of the drop, the director orientation is described by a family of circles passing through the singular point P (Fig. 4). These are tangential to a line PQ passing through P. In the next shell the tangent line P'Q' is such that it makes an angle θ with PQ. Every intersection of a circle on the first shell with a corresponding circle on the second shell makes an angle θ .

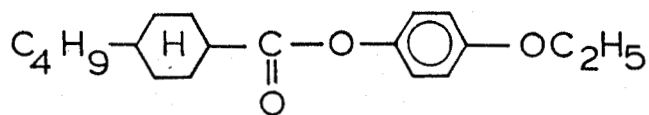

Ethoxy phenyltrans butyl cyclohexyl carboxylate
K 37 °C N 75 °C I

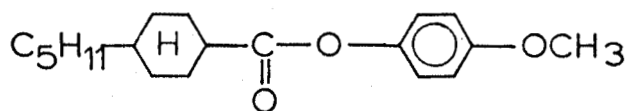

Methoxy phenyl trans pentyl cyclohexyl carboxylate
K 40 °C N 71 °C I

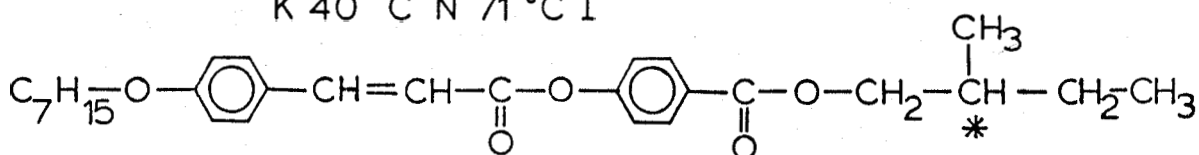

Methyl butyl benzoyloxy heptyloxy cinnamate
K 64 °C S_A 93 °C I

63.5 °C
C*

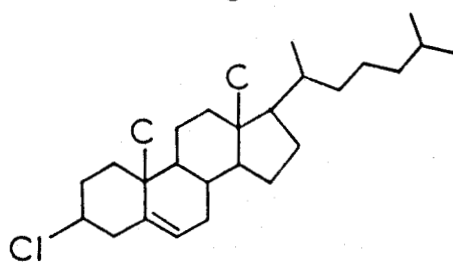

Cholesteryl chloride
K 97 °C I
62 °C
Cho

Figure 4.3

Structural formulae and transition temperatures of compounds used in the experimental studies.

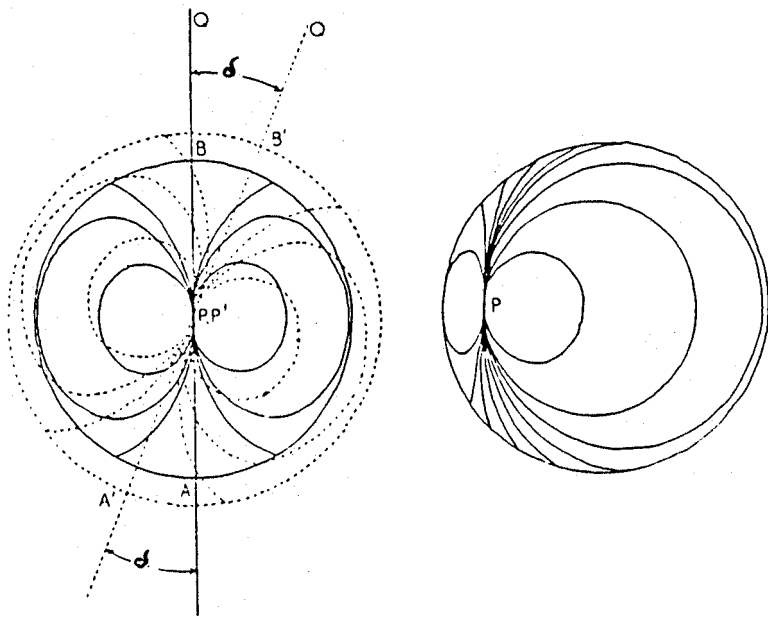

Figure 4.4

Family of circles constructed in accordance with Pryce and Frank's model. (From Robinson et al. 1958)

Concentric spheres have a sequence of such families making an angle $n\delta$ with the first, and the singular point moving out along a radius gives rise to the χ line. As the thickness of the cell is reduced the drops get flattened and then it is clear from Fig. 4.5a that the χ line extends only in the lateral curved region of the drop. In thin cells with $d \approx 8 \mu\text{m}$, cholesteric drops with a lateral diameter of 20–50 μm can be formed. These are highly flattened versions of the spherical drops described earlier. The director configuration is stretched such that the X line is now confined to the small lateral curved region, and has a length $\approx d/2$. The drops are surrounded by the isotropic phase on all sides and since the director has tangential alignment at the interface, the central 'flat' region of the drop has an essentially planar texture with the helical axis perpendicular to the flat surface. However, in each horizontal layer, the director has a splay-bend distortion and we can see 4 dark brushes emanating from the X line for suitable settings of the polariser and analyser which are set at suitable angles to get the dark brushes (Fig. 4.5b)

4.5 EFFECT OF A DC ELECTRIC FIELD ON THE CHOLESTERIC DROPS

In the experiment flat cholesteric drops were formed in cells with electrically conducting glass plates. On application of a DC electric field to the electrodes nothing happens as the voltage is increased gradually from 0 to 2 volts. At 2 volts

Figure 4.5

- a) Photograph of the cholesteric droplet showing the X defect line in a nearly spherical drop in a sample of thickness $\approx 150 \mu\text{m}$ (crossed polarisers x 1000). Note that the line defect extends only in the curved region of the droplet.
- b) A flat droplet of a left-handed cholesteric when $E = 0$. Analyser rotated by $\sim 20^\circ$ from the crossed position in relation to the polariser. The dark brushes emanate from the short X line near the edge of the droplet and signify a distorted director field in the cholesteric planes (x 1000).
- c) - h) Photographs of the drop shown in 4.5b at different times after the application of a voltage to the cell. (c,g,e) correspond to +2V and (d,f,h) to -2V.

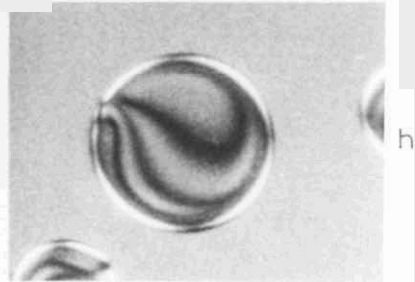
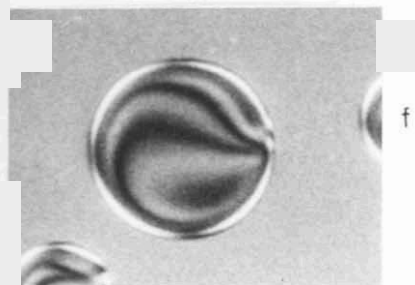
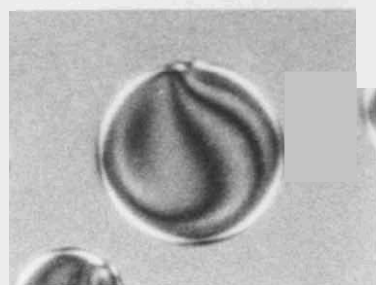
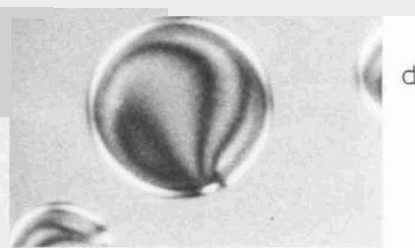
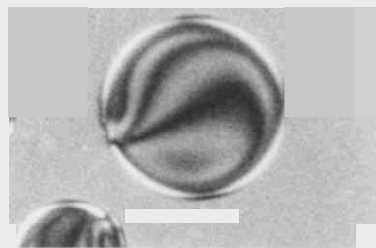
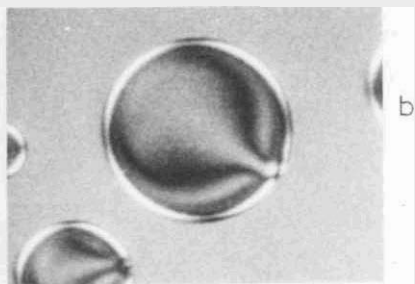
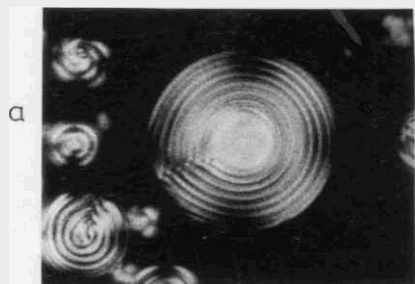

the dark brushes get curved such that all of them have the same curvature, unlike in the field free case (Fig. 4.5b). This results from a rearrangement in the director configuration and indicates that the reorientation of the director is easier if it is far away from the χ line. Then the whole structure starts rotating apparently without any further deformation of the director field (Fig. 4.5c - 4.5h). These rotating structures are indeed reminiscent of the diagrams sketched by Lehmann (1900, see also Chandrasekhar 1977). The angular velocity can be measured by observing the motion of the defect on the periphery of the drop. In order to minimise the errors in measurement the time taken for 10 rotations was noted and the average time required for one complete rotation obtained. The defect at the periphery of the drop could be clearly seen up to 3.5 volts and quite accurate measurements were possible.

Detailed observations lead to the following results:

- a) All the drops rotate in the same direction for a given sense of the field. The left handed system has a clockwise rotation when viewed along the field direction, and the right handed system has an anticlockwise rotation when viewed along the field direction. When the voltage is reversed, the curvature of the dark brushes and the sense of rotation of the structure reverse.

- b) The angular velocity does not depend on the radius of the drop, which shows that there is a rotation of the structure rather than that of the rigid body of the drop. It increases linearly with applied voltage up to ≈ 3.5 volts (Fig. 4.6) beyond which the structure of the drop changes (see Figs. 4.7a & 4.7b) and the rotational velocity becomes a non-linear function of the applied voltage.
- c) Though the angular velocity is roughly similar in all drops, some drops which touch either a glass plate or a dust particle rotate with a lower velocity.
- d) The extrapolated angular velocity tends to zero for $V = 1.9$ volts (see Fig. 4.6). The last point indicates that the DC field is totally screened up to ≈ 1.9 volts and the redox potential of at least one of the components in the mixture is ≈ 1.9 volts.

For a defect free sample, the solution corresponding to the Lehmann rotation is

$$\frac{d\phi}{dt} = \frac{v_E E}{\gamma_1}$$

where v_E is the electromechanical coefficient and E is the electric field, γ_1 is the rotational viscosity coefficient and ϕ is the azimuthal angle of \vec{n} . However before we use the experimental data to determine v_E , we have to note that the line defect which

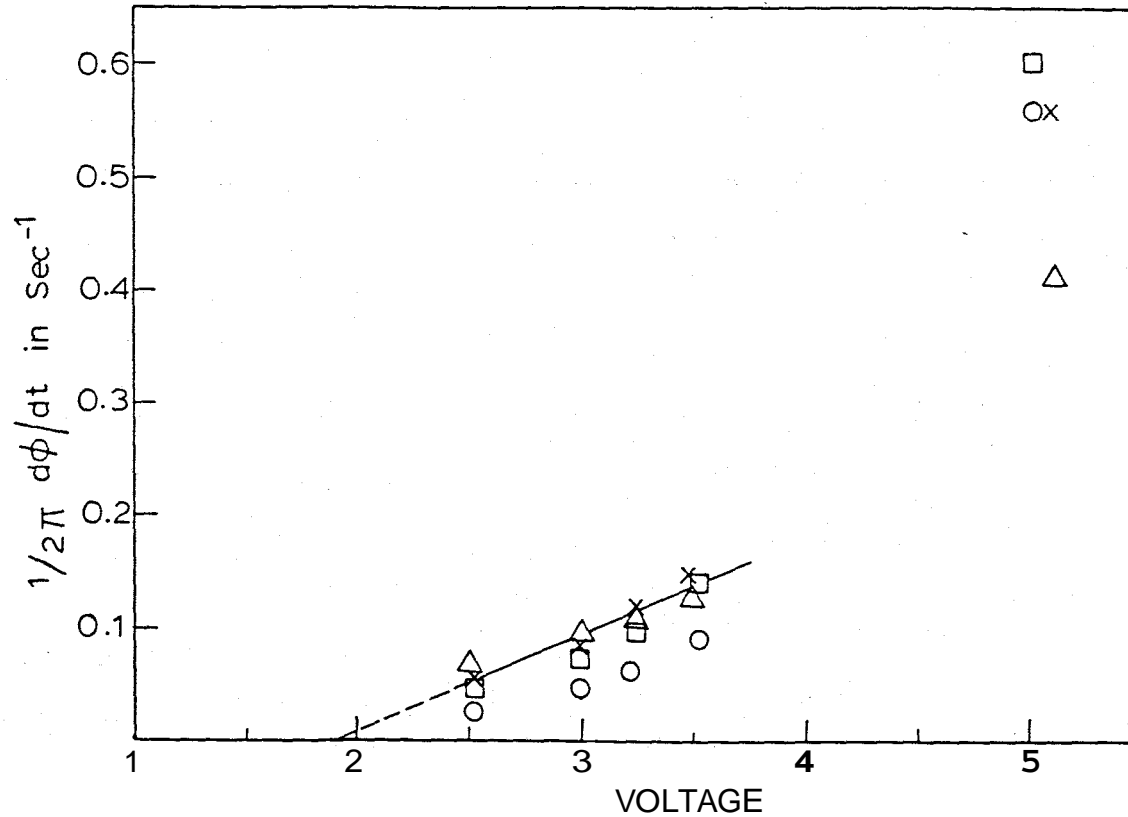

Figure 4.6

Plot of the rotational velocity of the structure as a function of applied voltage. Different symbols correspond to different drops. The slope of the straight line which corresponds to the drops with the fastest angular velocity is used in the calculations in the text. Between 3.5 volts and 5 volts there is a visible disturbance in the structure of the drops and measurements were not possible. At 5 volts and above the drop again has a uniform texture.

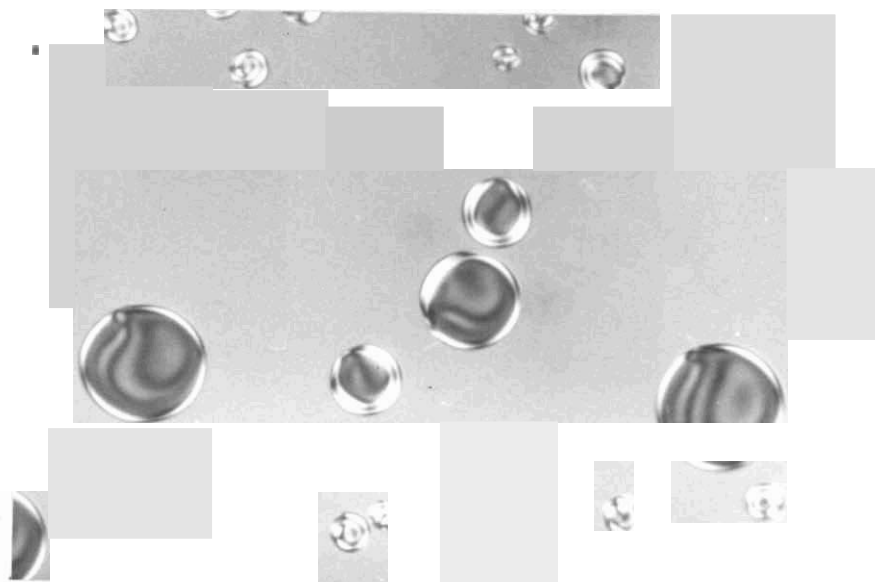

Figure 4.7a. Photograph of cholesteric droplets of the left handed system when $E = -2$ volts (x666). Analyser rotated by $\sim 20^\circ$ from the crossed position in relation to the polariser.

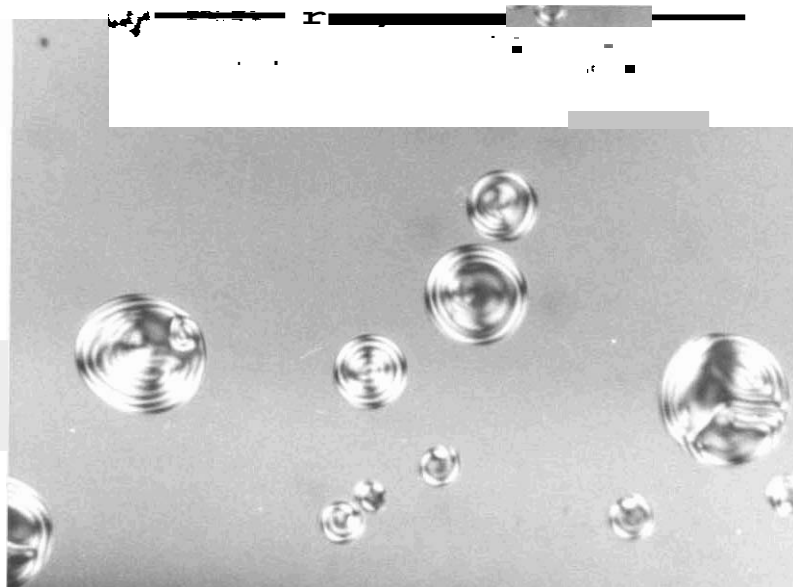

Figure 4.7b. Photograph of the same region of the sample as in Fig. 4.7a, when a field $E = -5$ volts is applied. (Note that the structure within the droplet has changed.)

is confined to the periphery of the drop also rotates with the structure. The deformation of the director field is extremely large near the χ line and the reorientation implied by the motion of the defect requires considerable energy. On the other hand, the coupling which drives the rotation of the director is confined to the 'planar' oriented flat part of the drop. The effective friction coefficient ζ (per unit length) for a slow motion of a nematic line singularity with a core has been estimated by Imura and Okano (1973) and de Gennes (1976). They have shown that $\zeta \propto s^2$, where s is the strength of the defect line. It is likely that the χ line of strength 2 would be coreless because of the collapse of the director in the third dimension (de Gennes 1975). It is easy to extend the formalism of Imura and Okano (1973) to this case.

Consider a straight disclination of integral strength in which the director has collapsed in the third dimension along the disclination. Let the disclination which lies along the z -axis move along the x -axis with a constant velocity u . The moving disclination disturbs the equilibrium director field around it. The direction of the director changes at each point with time and a viscous torque due to the surrounding medium results. Assuming that the motion of the disclination does not give rise to fluid flow the entropy production associated with the reorientation process is given by

$$\dot{T}\dot{S} = \iint \gamma_1 \dot{n}^2 dx dy \quad (4.22)$$

This entropy production is observed as a friction on the moving disclination. The effective friction coefficient ζ for the motion of the disclination can be obtained from $\dot{T}\dot{S} = \zeta u^2$.

The solution for the disclination is given by $\phi = s\alpha + c$, where $\alpha = \tan^{-1}(y/x)$ and for a director making an angle θ with the z-axis

$$\begin{aligned} \vec{n} &= [\cos \alpha s \sin \theta, \sin \alpha s \sin \theta, \cos \theta] \\ \dot{\vec{n}}^2 &= \left[\frac{d}{dt} (\cos \alpha s \sin \theta) \right]^2 + \left[\frac{d}{dt} (\sin \alpha s \sin \theta) \right]^2 \\ &\quad + \left[\frac{d}{dt} \cos \theta \right]^2 \\ \dot{\vec{n}}^2 &= \sin^2 \theta s^2 \left(\frac{\partial \alpha}{\partial t} \right)^2 + \left(\frac{\partial \theta}{\partial t} \right)^2 \end{aligned} \quad (4.23)$$

Therefore

$$\dot{T}\dot{S} = \gamma_1 \iint \left[\sin^2 \theta s^2 \left(\frac{\partial \alpha}{\partial t} \right)^2 + \left(\frac{\partial \theta}{\partial t} \right)^2 \right] dx dy \quad (4.24)$$

The solution for the tilt of the director around a defect with the director field collapsed in the third dimension is $\theta = 2 \tan^{-1}(r/R) |s|$ where $r^2 = x^2 + y^2$ and R is the range over which the 'collapse' has occurred (Meyer 1973). For a defect moving very slowly along the x-axis with velocity u ,

$$a = \tan^{-1} (y/x - ut)$$

$$\theta = 2 \tan^{-1} \left[\frac{[(x-ut)^2 + y^2]^{1/2}}{R} \right]^s \quad (4.25)$$

i.e.,

$$\tan \frac{\theta}{2} = \left[\frac{(x-ut)^2 + y^2}{R^2} \right]^{s/2} \quad (4.26)$$

From eqns. (4.25) and (4.26) we have

$$\frac{\partial \alpha}{\partial t} = \frac{uy}{[(x-ut)^2 + y^2]} \quad (4.27)$$

and

$$\frac{\partial \theta}{\partial t} = - \frac{2us(x-ut)}{R^s [(x-ut)^2 + y^2]^{1-s/2}} \frac{1}{\left[1 + \left\{ \frac{(x-ut)^2 + y^2}{R^2} \right\}^s \right]} \quad (4.28)$$

Equation (4.24) now becomes

$$\begin{aligned} T\dot{s} &= \gamma_1 \iint \left[\frac{4[(x-ut)^2 + y^2]^s}{R^{2s}} \frac{s^2 u^2 y^2}{[(x-ut)^2 + y^2]^2} \frac{1}{\left[1 + \frac{\{(x-ut)^2 + y^2\}^s}{R^{2s}} \right]^2} \right. \\ &\quad \left. + \frac{4u^2 s^2 (x-ut)^2}{R^{2s} [(x-ut)^2 + y^2]^{2-s}} \frac{1}{\left[1 + \frac{\{(x-ut)^2 + y^2\}^s}{R^{2s}} \right]^2} \right] dx dy \\ &= \frac{\gamma_1 4s^2 u^2}{R^{2s}} \iint \frac{[(x-ut)^2 + y^2]^{s-1}}{\left[1 + \frac{[(x-ut)^2 + y^2]^s}{R^{2s}} \right]^2} dx dy \quad (4.29) \end{aligned}$$

If u is very small

$$\begin{aligned} \dot{T}S &= \frac{4\gamma_1 s^2 u^2}{R^{2s}} \int_0^R \frac{(r^2)^{s-1}}{\left[1 + \left\{\frac{r^{2s}}{R^{2s}}\right\}^2\right]} 2\pi r \, dr \\ &= \frac{8\pi\gamma_1 s^2 u^2}{R^{2s}} \frac{R^{2s}}{4s} \end{aligned}$$

Therefore

$$\dot{T}S = 2\pi\gamma_1 s u^2 \quad (4.30)$$

The friction coefficient ζ is then a linear function of $|s|$ and is given by $2\pi\gamma_1 |s|$.

4.6 ESTIMATION OF THE ELECTROMECHANICAL COUPLING COEFFICIENT

We now make use of the entropy production due to the motion of the disclination in the energy rate balance equation of a cholesteric drop with its structure undergoing a 'Lehmann rotation',

$$2\pi\gamma_1 |s| u^2 \frac{d}{2} + \pi r^2 d \gamma_1 \left(\frac{d\phi}{dt}\right)^2 \approx \pi r^2 d v_E E \frac{d\phi}{dt} \quad (4.31)$$

where the defect is assumed to have a length $= d/2$, r is the radius of the drop and $u = r \frac{d\phi}{dt}$ is the linear velocity of the defect.

Therefore

$$\gamma_1 |s| \frac{d\phi}{dt} + \gamma_1 \frac{d\phi}{dt} = v_E E$$

since $s = 2$,

$$3\gamma_1 \left(\frac{d\phi}{dt} \right) = v_E E$$

or

$$\frac{d\phi}{dt} = \frac{v_E E}{3\gamma_1} \quad (4.32)$$

in the presence of a line defect rotating with the structure. In the absence of a line defect we recover the equation $\frac{d\phi}{dt} = \frac{v_E E}{\gamma_1}$. The cholesteric drops that we have studied do not have the ideal defect free planar configuration. The presence of the X line defect and the associated deformation of the director field helps in visualising the rotation of the structure.

We have used eqn (4.32) in our calculations of the electro-mechanical coupling coefficient. Using the slope of the linear part of the $d\phi/dt$ vs. V curve, corresponding to the drops with the fastest angular velocity and $\gamma_1 = 0.7$ poise which is the value for a typical room temperature nematic (see for e.g., de Gennes 1975) we obtain a value of $|v_E| \approx 0.28$ cgs units.

The sign of the coupling coefficient can be determined by noting the sense of rotation of the structure in the drops with respect to the applied field direction. In the system with a left handed helix there was an anticlockwise rotation when viewed in a direction opposite to the field. $d\phi/dt$ is thus positive, attributing a positive sign to v_E . Further as the system has a pitch

$\sim 5 \mu\text{m}$, v_E/q has a negative sign and is about -2×10^{-5} cgs units.

4.7 CONCLUSION

We have devised a simple technique to reproduce the Lehmann rotation experiment under the action of an external DC electric field. We have checked that the phenomenon satisfies all the required symmetry properties, viz., the rotational velocity linearly depends on \vec{E} and v_E , the coupling coefficient changes sign with that of q . The cholesteric drops that we have studied do not have the ideal defect free planar configuration assumed in deriving the theoretical results, but the presence of the line defect and the associated deformation of the director field actually helps in visualising the rotation of the structure. We have allowed for the entropy production involved in the motion of the defect line in an approximate manner and this permits us to estimate the coupling coefficient v_E . In the system studied v_E/q has a negative sign equal to -2×10^{-5} cgs units whose magnitude is similar to that of the estimate made by dimensional arguments.

REFERENCES

- Berreman, D. 1972 Phys. Rev. Lett., 28, 1683
- Berreman, D. 1973 Mol. Cryst. Liq. Cryst., 23, 215
- Boccaro, N. (Ed.) Symmetries and Broken Symmetries in Condensed Matter Physics (Idset, Paris, 1981)
- Candau, S., Leroy, P. and Debeauvais, F. 1973 Mol. Cryst. Liq. Cryst., 23, 283 .
- Chandrasekhar, S. 1977 Liquid Crystals (Cambridge University Press)
- Chandrasekhar, S., Kini, U.D. and Ranganath, G.S. 1980 in 'Liquid Crystals', Ed. S.Chandrasekhar (Heyden, London), p. 247
- Chandrasekhar, S. and Suresh, K.A. (private communication)
- de Gennes, P.G. 1975 The Physics of Liquid Crystals (Clarendon, Oxford)
- de Gennes, P.G. 1976 in 'Molecular Fluids', Eds. R.Balian and G.Weill (Gordon & Breach, London), p. 373.
- Dubois-Violette, E. and Parodi, O. 1969 J. de Phys., 30, C4-57
- Eber, N. and Janossy, I. 1982 Mol. Cryst. Liq. Cryst. Lett., 72, 233

- Eber, N. and Janossy, I. 1984 Mol. Cryst. Liq. Cryst., 102, 311
- Faetti, S. and Palleschi, V. 1984 Phys. Rev., **A30**, 3241
- Helfrich, W. 1969 Phys. Rev. Lett., 23, 372
- Imura, H. and Okano, K. 1973 Phys. Lett., **42A**, 403
- / Janossy, I. 1981a J. de Phys. Lett., 42, L-41
- , Janossy, I. 1981b in "Liquid Crystal Research and Applications",
Ed. L.K. Bata (Pergamon, New York), p. 625
- Jayaram, H.K., Kini, U.D., Ranganath, G.S. and Chandrasekhar, S.
1983 Mol. Cryst. Liq. Cryst., 99, p. 155
- Lehmann, O. 1900 Ann. Phys., 2, 649
- Leslie, F.M. 1968 Proc. Roy. Soc., **A307**, 359
- Leslie, F.M. 1979 in "Advances in Liquid Crystals^m", Vol. 4, Ed.
G.H. Brown (Academic, New York), p. 1.
- Lubensky, T.C. 1972 Phys. Rev., **A6**, 452
- Lubensky, T.C. 1973 Mol. Cryst. Liq. Cryst., 23, 99
- Martin, P.C., Parodi, P. and Pershan, P.J. 1972 Phys. Rev., **A6**,
2401
- Meyer, R.B. 1973 Phil. Mag., 27, 405

- Pleiner, H. and Brand, H.P. 1987 Mol. Cryst. Liq. Cryst., 5, 61
- Pomeau, Y. 1971 Phys. Lett., A34, 143
- Prost, J. 1972 Solid State Commun., 11, 183, and xii
- Ranganath, G.S. 1983 Mol. Cryst. Liq. Cryst. Lett., 92, 105
- Robinson, C. 1956 Trans. Faraday Soc., 52, 571
- Robinson, C., Ward, J.C. and Beevers, K.R.B. 1958 Disc. Faraday Soc., 25, 41
- Wolff, V., Grubel, W. and Kruger, A. 1973 Mol. Cryst. Liq. Cryst., 23, 187.