

**Resistance without resistance:
An anomaly**

N. Kumar

Raman Research Institute, Bangalore 560 080, India

The elementary two-terminal network consisting of a resistively (R) shunted inductance (L) in series with a capacitively (C) shunted resistance (R) with $R = \sqrt{L/C}$, is known for its non-dispersive dissipative response, i.e. with the input impedance $Z_0(\omega) = R$, independent of the frequency (ω). In this communication, we examine the properties of a novel equivalent network derived iteratively from this two-terminal network by replacing everywhere the elemental resistive part R with the whole two-terminal network. This replacement suggests a recursion $Z_{n+1}(\omega) = f(Z_n(\omega))$, with the recursive function $f(z) = (i\omega Lz/i\omega L + z) + (z/1 + i\omega Cz)$. This recursive map has two fixed points – an unstable fixed point $Z_u^* = 0$, and a stable fixed point $Z_s^* = R$. Thus, resistances at the boundary terminating the infinitely iterated network can now be made arbitrarily small without changing the input impedance $Z_\infty (= R)$. This, therefore, leads to realizing in the limit $n \rightarrow \infty$, an effectively dissipative network comprising essentially the non-dissipative reactive elements (L and C) only. Hence the oxymoron–resistance without resistance! This is best viewed as a classical anomaly akin to the one encountered in turbulence. Possible application as a formal decoherence device – the fake channel – is briefly discussed for its quantum analogue.

Keywords: Classical anomaly, dissipation, disorder, fake channels, fixed point, iteration, localization.

CONSIDER an elementary two-terminal LCR network shown in Figure 1. This series–parallel combination of the resistively (R) shunted inductance (L) in series with the capacitively (C) shunted resistance (R) with, $R = \sqrt{L/C}$, has a dispersionless dissipative input impedance $Z_0(\omega) = R$, independent of the circular frequency (ω). This readily verifiable result is, of course, known, though not as commonly as one would have expected it to be. (The equivalence is detailed in that, e.g. the Nyquist–Johnson noise powers generated by the two shunt resistors (R) at temperature T , say, combine to give a noise output at the (1–2)-terminal equal to that for a single resistance R at temperature T .) The structure of this two-terminal network admits iteration generating an equivalent network as indicated in Figure 2, which is much familiar as a ladder network¹. Consider such an iterated network, but now terminated arbitrarily at the boundary. With this, we can write the recursion relation

$$Z_{n+1} \equiv f(Z_n) = \frac{i\omega LZ_n}{i\omega L + Z_n} + \frac{Z_n}{1 + i\omega CZ_n}. \tag{1}$$

This recursion has two fixed points, $Z^* = f(Z^*)$, giving $Z^* = 0, R$. Linear stability analysis of these fixed points is readily done. A perturbation z_0 about the fixed point $Z^* = 0$, iterates away giving $|z_{n+1}| = 2|z_n|$, making $Z^* = 0$ an unstable fixed point $Z_u^* (= 0)$. Next, consider the fixed point $Z^* = R$. A perturbation z_0 about R , iterates as

$$z_{n+1} = \frac{1 - \omega^2 LC}{(1 + i\omega\sqrt{LC})^2} z_n,$$

giving

$$\left| \frac{z_{n+1}}{z_n} \right|^2 = \left| \frac{1 - \omega^2 LC}{1 + \omega^2 LC} \right|^2 \leq 1. \tag{2}$$

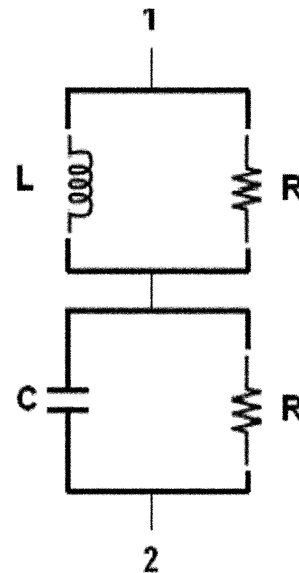

Figure 1. Dispersionless two-terminal LCR network with $R = \sqrt{L/C}$.

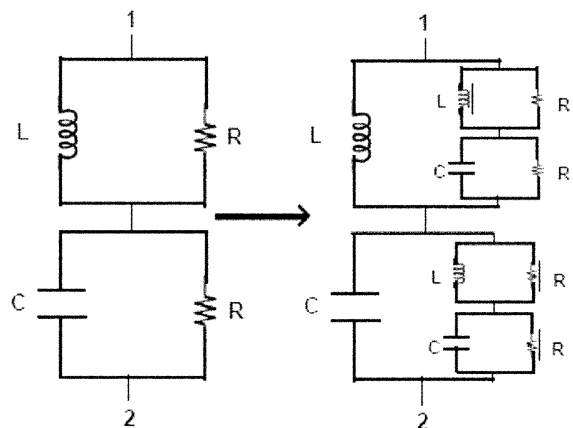

Figure 2. Iteration of the two-terminal network with $R (= \sqrt{L/C})$ replaced recursively by the whole two-terminal network. Shown here is one stage of iteration.

e-mail: nkumar@rri.res.in

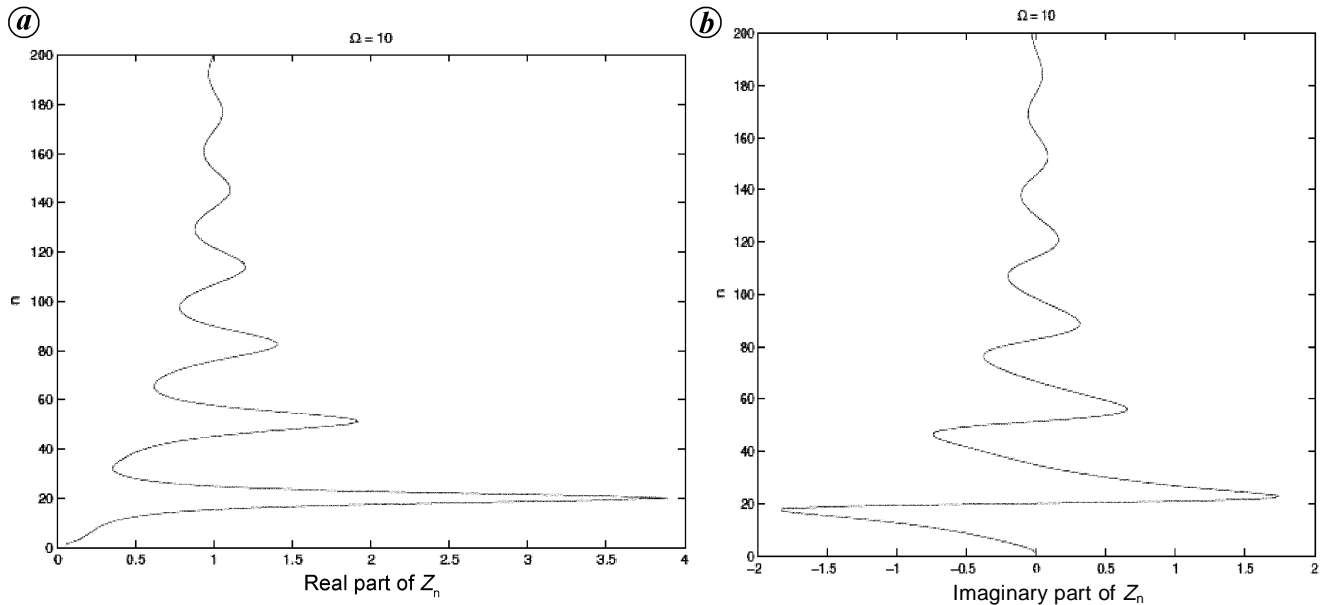

Figure 3. *a*, Iteration of the two-terminal network impedance ($\text{Re } Z_n(\omega)$) initialized at $Z_0 = 0.05 + i0$. Note the fast convergence to the stable fixed point $Z_n^* = 1$. Here $R = L = C = 1$, and $\omega = 10$. *b*, Iteration of the two-terminal network impedance ($\text{Im } Z_n(\omega)$) initialized at $Z_0 = 0.05 + i0$. Note the fast convergence to the stable fixed point $Z_n^* = 1$. Here $R = L = C = 1$ and $\omega = 10$.

This makes the fixed point $Z_n^* (= R)$ stable. The implication of this fixed-point analysis is now straightforward. Terminating the network at the boundary with $z_0 = r_0 + ix_0$, where r_0 can be made arbitrarily small (but non-zero positive), the impedance will iterate away to the stable fixed point $Z_n^* = R$ as $n \rightarrow \infty$. This is, however, so assuming that there are no other attractors. We have, therefore, carried out the recursion in eq. (1) numerically with different initializations, and a typical evolution is shown in Figure 3 *a* and *b*.

Again, note the fast recursive convergence to the fixed point $Z_n^*/R \rightarrow 1$. This is the all important point – an arbitrarily small resistive termination at the boundary generates a finite resistance $R = \sqrt{L/C}$ in the limit $n \rightarrow \infty$. And this result suffices for our purpose. (Inasmuch as the recursion holds for all values of the frequency ω , other attractors, if any, e.g. a period-doubling (two-cycle) attractor, would generate infinitely many isospectral networks. Such attractors, or indeed a strange attractor, should be interesting for network synthesis.) The physical picture, of course, is just this¹. The energy fed at the input terminal into the infinitely iterated network appears to be absorbed effectively resistively at the input terminal. But, in fact, it is really not dissipated there instantaneously and locally – it is cascaded away to the distant boundary where it is ultimately dissipated. In a steady state a.c. response, for instance, much energy remains stored in the reactive elements. This is strongly reminiscent of what happens in fluid turbulence. There too, energy fed at the large-scale eddy (integral regime) is cascaded away progressively to smaller-scale eddies (inertial regime), and is ultimately dissipated

at the distant smallest (Kolmogorov) scale – of viscosity. Indeed, the dissipation rate becomes independent of the viscosity in the limit of vanishingly small viscosity! This is a classic example of the classical dissipative anomaly² in the technical sense of the term – the time-reversible symmetry remains broken even as the symmetry-breaking parameter (the viscosity) tends to zero, giving dissipation without dissipation!

The conceptual similarity to our network is obvious (and not a little because of the inward-bound nature of our iterated network that makes the drawing in Figure 2 increasingly more difficult beyond even the second stage of iteration). It will be apt at this stage to note that yet another example of such an anomaly is encountered in the context of infinite-ladder networks of inductors and capacitors^{3,4}, where finite dissipation arises as a result of a subtle limiting procedure well known in the context of phase transitions. The networks are, however, essentially low-pass filters and the input impedance is not dispersionless. We may note in passing that the iterated network is hierarchical in its geometry.

Our analysis of the iterated network has implications for dissipative quantum mechanics. It is known that there is no simple way of introducing dissipation phenomenologically into a Hamiltonian quantum system without inconsistencies⁵. A way out in the context of quantum transport has been to introduce fake channels^{5,6}, such as transmission lines that outcouple part of the wave amplitude causing the so-called stochastic attenuation. Our infinitely iterated network is essentially a *lumped*-element transmission line where the reactive elements can be con-

sidered as part of the Hamiltonian system, and dissipation enters only through the anomaly discussed above. A quantum version of our iterated network is the Cayley tree composed of one-dimensional scatterer as introduced by Shapiro⁷ in the context of quantum conduction in parallel resistors using splitters.

An interesting feature of our network is its invariance with respect to a certain correlated disorder, namely that the condition $R = \sqrt{L/C}$ (fixed) allows us to vary L and C for a given R at random with the strong correlation, without leading to Anderson wave-localization^{8,9} that would have blocked energy cascading. This is a case of purely gauge disorder.

In conclusion, we have analysed a two-terminal LCR network which is dispersionless and admits hierarchical iteration. When infinitely iterated, it gives an essentially reactive (L and C) network and yet provides dissipation – through an anomaly. Possible application to dissipative quantum systems is pointed out. The network admits correlated disorder without localization.

1. Feynman, R. P., *The Feynman Lecturers on Physics*, Narosa, New Delhi, 1986, vol. II.
2. Falkovich, G. and Sreenivasan, K. R., Lessons from hydrodynamic turbulence. *Phys. Today*, 2006, 43–49.
3. van Enk, S. J., Paradoxical behavior of an infinite ladder network of inductors and capacitors. *Am. J. Phys.*, 2000, **68**, 854–856.
4. Krivine, H. and Lesne, A., Phase transition-like behavior in a low-pass filter. *Am. J. Phys.*, 2003, **71**, 31–33.
5. Dekker, H., Classical and quantum-mechanics of the damped harmonic oscillators. *Phys. Rep.*, 1981, **80**, 1–112.
6. Buettiker, M., Irreversibility and dephasing from vacuum fluctuations, 2001, cond-mat/0106149.
7. Shapiro, B., Quantum conduction on a Cayley tree. *Phys. Rev. Lett.*, 1983, **50**, 747–750.
8. Anderson, P. W., Absence of diffusion in certain random lattices. *Phys. Rev.* 1958, **109**, 1492–1505.
9. Samelson, G., Gredeskul, S. A. and Mazar, R., Resonances and localization of classical waves in random systems with correlated disorder. *Phys. Rev. E*, 1999, **60**, 6801–6890.

ACKNOWLEDGEMENTS. I came to know of this dispersionless network from V. Radhakrishnan, RRI, Bangalore, and would like to thank him for the same. Its provenance, however, remains untraceable. Thanks are also due to Andral Narayanan, RRI for help with the fixed-point analysis numerically.

Received 22 May 2007; revised accepted 6 July 2007

A view-based approach for the reconstruction of optical properties of turbid media

Atul Srivastava*, H. S. Patel and P. K. Gupta

Laser Biomedical Applications and Instrumentation Division,
Raja Ramanna Centre for Advanced Technology, Indore 452 013, India

A view-based approach for the computation of updates of optical parameters of a turbid medium is discussed. The approach differs from conventionally employed reconstruction techniques in terms of implementation of the computed updates. Simulation studies in frequency domain for tissue phantoms approximated by slab geometry have been presented. Results of the study show that the proposed inversion scheme, wherein the projection data corresponding to each view has been handled individually, works well in predicting the presence of an inhomogeneity. A comparison with the reconstruction results of conventionally employed inversion schemes involving simultaneous handling of projection data from all the view angles shows that the accuracy of the proposed scheme in predicting the presence of single inhomogeneity is higher and the reconstruction is also relatively free of artifacts. On the other hand, in the presence of multiple inhomogeneities, though the simultaneous handling of all the views gives better reconstruction, the updates obtained by the proposed scheme can be employed as close a priori information about the approximate positions of the inhomogeneities, thereby reducing the overall dimension of the Jacobian matrix to be inverted and hence making the convergence faster.

Keywords: Diffuse optical tomography, image reconstruction, optical properties, turbid medium.

OVER the past decade, diffuse optical tomography (DOT) has emerged as a viable method for non-invasive measurements of optical properties of highly scattering media and monitoring of living tissues^{1–3}. Since DOT presents a typical ill-posed inverse problem with a limited number of measurements, use of an appropriate reconstruction algorithm is important. Hence, there has been considerable interest in the development of fast and accurate reconstruction algorithms. An iterative Newton–Raphson algorithm was employed by Pogue *et al.*⁴ for the reconstruction of optical parameter distribution using a multigrid finite difference solution of the frequency domain diffusion equation. Jiang *et al.*⁵ used a finite element-based reconstruction algorithm under diffusion approximation to simultaneously reconstruct the images of both absorption and scattering coefficients. Model *et al.*⁶ introduced an iterative reconstruction algorithm for near-infrared imaging by

*For correspondence. (e-mail: atulsr@cat.ernet.in)