

7. Novel Addressing Methods for Fast Responding LCDs

Temkar N. Ruckmongathan

The passive matrix displays based on Super Twisted Nematic (STN) Liquid Crystal Displays (LCDs) are popular due to their low cost. However, the response times of these displays are in the range of 200 ms. The improvement of response times of STN LCDs to about 50 ms results in poor contrast ratio, when conventional addressing technique is used. This is due to the frame response phenomenon in fast responding LCDs. Novel addressing techniques to suppress the frame response phenomenon are presented. These techniques lead to a high contrast ratio, good brightness uniformity and lower supply voltage as compared to the conventional technique. The basic principle of these addressing techniques and methods for displaying gray shades are discussed.

1 Introduction

Liquid Crystal Displays (LCDs) are the market leader among the various flat panel displays available today. Of the large format flat panel displays, the passive matrix STN LCDs are more popular than the Active matrix TN LCDs due to their low cost. However the response times, the brightness uniformity and viewing angle characteristics of STN LCDs are poor as compared active matrix LCDs.

The development of fast responding STN LCDs with high contrast ratios, wide viewing angle and good brightness uniformity of pixels is of current practical interest. The performance of the conventional addressing technique is not adequate as the response times of STN LCDs are reduced to about 50 ms. Novel addressing techniques that are suitable for driving such relatively fast responding LCDs are discussed.

1.1 Matrix displays

In most of the flat panel displays, the picture elements or pixels are inter-connected in the form of matrix and hence are called Matrix displays. The rows and columns in a matrix display are orthogonal to each other. The pixels are located at the intersection of

rows and columns. The method employed for driving the pixels in a matrix display to the desired state (either ON or OFF) is called Addressing or Multiplexing.

Matrix LCDs can be broadly classified as passive matrix displays and active matrix displays, from the point of addressing. Passive matrix displays have simple structure. The intrinsic non-linear characteristics of the LCD are used for addressing passive matrix LCDs. Active matrix LCDs have an additional non-linear element (two terminal diode or three terminal transistor) at each pixel in the display. The addition of non-linear elements in active matrix relaxes the stringent requirements to be met by the display device and addressing techniques in a passive matrix displays. The passive matrix displays are more cost effective as compared to the active matrix displays. However, the passive matrix LCDs pose a challenge from the point of development of suitable device characteristics and addressing techniques to improve the display performance.

1.2 Conventional addressing technique

The conventional addressing technique for passive matrix LCDs was proposed by Alt and Pleshko⁽¹⁾ in 1974. LCDs are relatively slow responding devices with switch ON or switch OFF time in the range of 50~200 ms. Hence the electro-optic response of LCDs depends on root mean squared (rms) voltage rather than the instantaneous voltage, for a wide range of scanning frequencies.

A matrix display having N rows and M columns is scanned one line at a time, using rectangular pulse waveforms as shown in **Fig. 1**. The scanning lines can be either the rows or columns of a matrix display. Row electrodes are set to be the scanning lines and the column electrodes are assigned to be the data lines in this paper.

In the conventional technique a row is selected with a voltage of $+V_r$ (or $-V_r$), while the rest of non-selected rows are at ground potential (middle voltage between the positive and negative row select voltages). The data voltages which are applied to all the columns simultaneously are either in phase (same sign as the row select voltage) for an OFF pixel and out of phase (opposite sign of row select voltage) for an ON pixel. The amplitude of the column voltage is V_c , which is different from the amplitude of the row select pulse. In general it is desirable to achieve as high a rms voltage as possible across all ON pixels (V_{on}) and as low a voltage as possible across all OFF pixels (V_{off}). Hence it is appropriate to maximize the ratio (V_{on}/V_{off}). This ratio is called the selection ratio. Alt and Pleshko⁽¹⁾ optimized this ratio and showed that the selection ratio is maximum when $V_r = N^{1/2} \cdot V_c$ and the maximum value is $(V_{on}/V_{off}) = [(N^{1/2} + 1)/(N^{1/2} - 1)]^{1/2}$.

This is also the maximum value obtainable by any addressing technique as shown by Nehring and Kmetz⁽²⁾ as well as Clark, Shanks and Patterson⁽³⁾.

The following important observations are made,

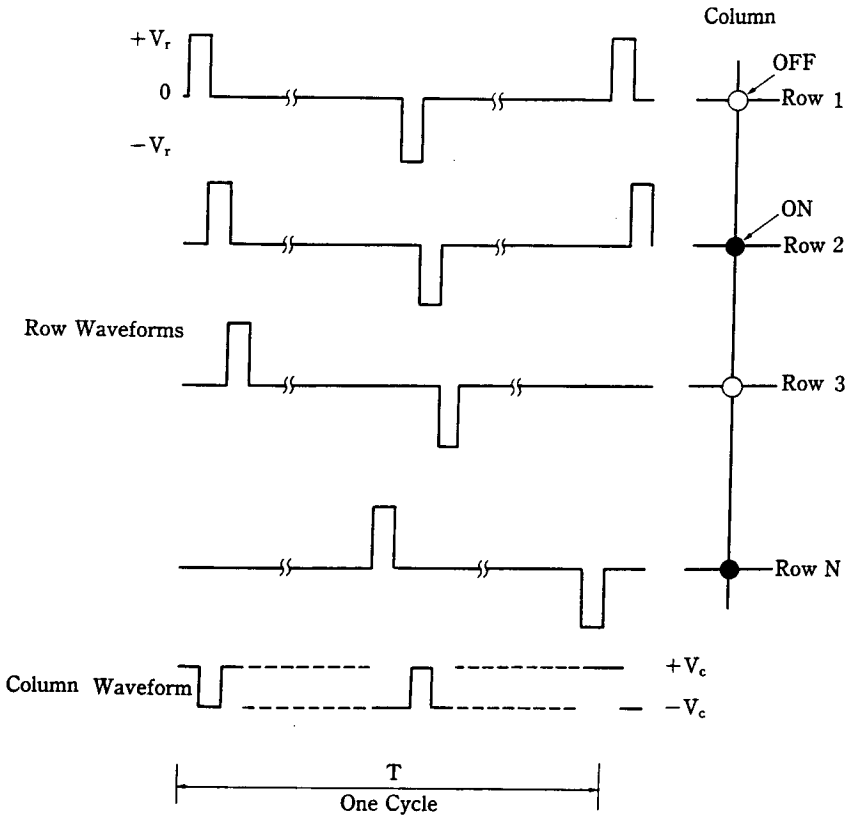

Fig. 1 Typical waveforms of the conventional addressing technique.

- 1) the voltage across pixels corresponds to the information to be displayed only when the corresponding row is selected. Hence the address duty factor is $(1/N)$.
- 2) the instantaneous voltage across OFF pixels far exceeds the threshold value for a short duration of time when the corresponding row is selected (during $(1/N)$ of the total time).
- 3) the selection ratio decreases rapidly when the number of rows multiplexed is increased.

The conventional technique is adequate when the response time is much larger (a factor of ten or more) as compared to the period of the addressing waveforms. However when the response time is comparable (a factor of 3 or 4) to the period of the addressing waveforms, the contrast ratio of the display decreases due to frame response phenomenon⁽⁴⁾ as explained below.

1.3 Frame response

The amplitude of the voltage across a pixel is very much larger than the threshold of the LCDs for a short duration of time. This is especially true for large values of N . The light transmission through the ON and OFF pixels are shown in **Fig. 2**. Light transmission through ON pixels which is high during the row select time decreases rapidly due to relaxation of liquid crystal molecules. The light transmission through OFF pixel increases, since the amplitude of the voltage across it is large when the row is selected. Increase in OFF pixel transmission relatively contributes more to decrease of contrast ratio than the decrease in ON transmission.

Hence, the frame response observed in fast responding LCDs is primarily due to large amplitude of pulses in the addressing waveforms and the relatively long time between two such pulses.

- 1) The amplitude of the row select voltage can be reduced to suppress the frame response⁽⁶⁾. This results in reduction of selection ratio and hence the contrast ratio.
- 2) Alternatively, the scanning frequency can be increased⁽⁶⁾. Here, the period of the addressing waveforms is reduced such that it is very much small as compared to the response times of the LCD. This results in poor brightness uniformity of pixels, since the row select pulse width reduces as the frame frequency is increased.

The observations made above imply that a different approach is necessary to suppress the frame response. Several new addressing techniques like the Binary Addressing technique⁽⁷⁾ (BAT), the Improved Hybrid Addressing Technique⁽⁸⁾ (IHAT) were

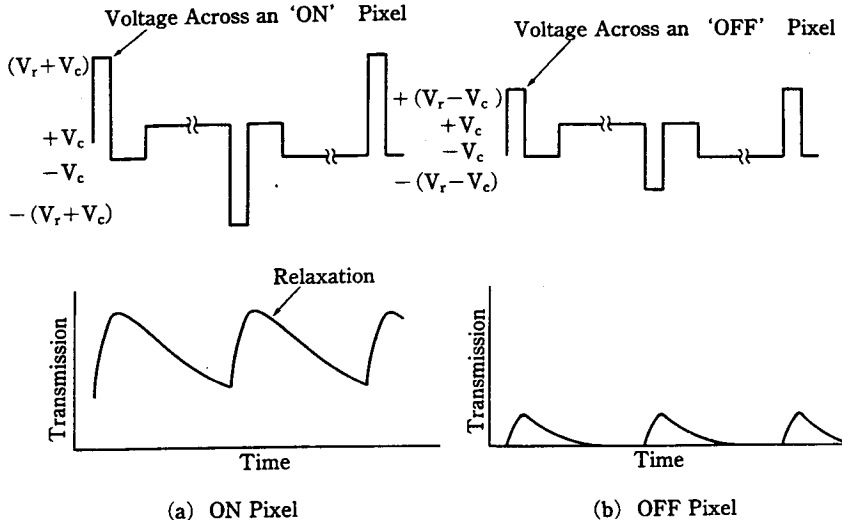

Fig. 2 Light transmission in fast responding STN LCDs shows frame response.

proposed for driving the rms responding LCDs. All these techniques are based on selecting more than one address line at a given instant of time. The advantages of IHAT are :

The amplitude of the row select voltage decreases with L , the number of address lines in a subgroup which are selected simultaneously. The selection ratio is maximum here and is not affected by the reduction in the row select voltage.

The address duty factor increases with L and hence the time duration between two row select pulses can be reduced. This has the same effect as increasing the frame frequency without decreasing the row select pulse width, which is not possible in the conventional addressing technique.

These are desirable characteristics for suppressing the frame response. It is clear from the above discussion that disadvantages associated with reduction of amplitude of the row select voltage and the increase of frame frequency in the conventional addressing technique are not present when IHAT is used for addressing fast responding LCDs⁽⁹⁾. Novel addressing techniques suitable for suppressing frame response in fast responding LCDs are discussed next.

2 Novel Addressing Techniques

Addressing techniques for driving passive matrix are based on using orthogonal functions. The conventional line by line addressing uses rectangular block functions (shown in Fig. 1), which are orthogonal. While the rectangular block functions are the simplest of all the orthogonal functions novel addressing techniques use other functions which are a bit more complex. The orthogonal functions are introduced in the following section.

2.1 Orthogonal functions

A set of functions are said to be orthogonal when integral of the product of any two functions is zero as shown below :

The series of functions $F_i(t)$ where in $i=0, 1, 2, \dots$ is said to be orthogonal in the period T when

$$\int_0^T F_i(t) \cdot F_j(t) \cdot dt = \begin{cases} K & \text{when } i=j \\ 0 & \text{when } i \neq j \end{cases} \quad (1)$$

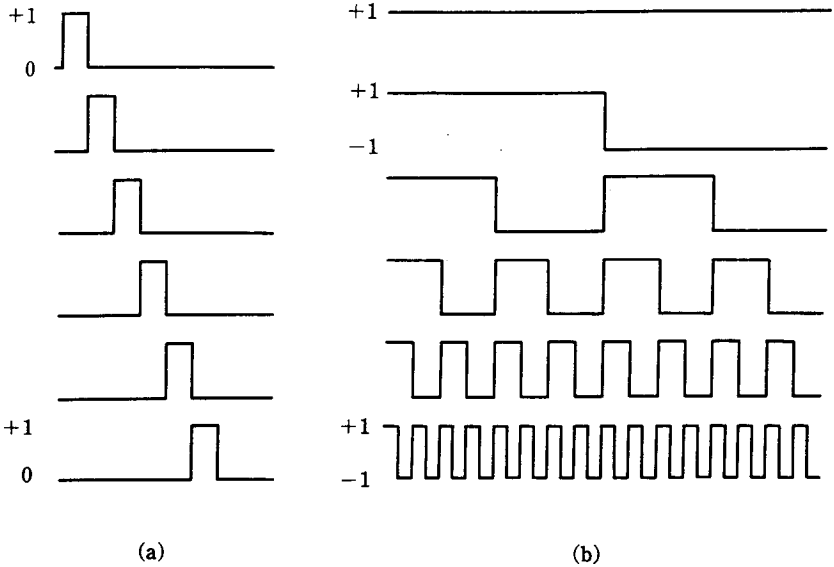

Fig. 3 (a) Rectangular block functions and (b) Rademacher functions.

The rectangular block pulses shown in **Fig. 3. (a)** satisfy this relation. Another set of orthogonal function is the Rademacher functions shown in **Fig. 3. (b)** consisting of square waveforms of different frequencies. The square waveforms have an amplitude of either +1 or -1. For example a set of four Rademacher functions which are orthogonal to each other are shown below :

$$\begin{aligned}
 F_1 &= \{+1, -1, +1, -1, +1, -1, +1, -1, +1, -1, +1, -1, +1, -1, +1, -1\} \\
 F_2 &= \{+1, +1, -1, -1, +1, +1, -1, -1, +1, +1, -1, -1, +1, +1, -1, -1\} \\
 F_3 &= \{+1, +1, +1, +1, -1, -1, -1, -1, +1, +1, +1, +1, -1, -1, -1, -1\} \\
 F_4 &= \{+1, +1, +1, +1, +1, +1, +1, +1, -1, -1, -1, -1, -1, -1, -1, -1\}
 \end{aligned}$$

These orthogonal functions can also be represented in matrix form as shown below :

$$[A] = \begin{bmatrix}
 +1 & -1 & +1 & -1 & +1 & -1 & +1 & -1 & +1 & -1 & +1 & -1 & +1 & -1 & +1 & -1 \\
 +1 & +1 & -1 & -1 & +1 & +1 & -1 & -1 & +1 & +1 & -1 & -1 & +1 & +1 & -1 & -1 \\
 +1 & +1 & +1 & +1 & -1 & -1 & -1 & -1 & +1 & +1 & +1 & +1 & -1 & -1 & -1 & -1 \\
 +1 & +1 & +1 & +1 & +1 & +1 & +1 & +1 & -1 & -1 & -1 & -1 & -1 & -1 & -1 & -1
 \end{bmatrix}$$

The Rademacher matrix with i rows has 2^i columns. The number of columns in the orthogonal matrix corresponds to the number of time intervals necessary to address a display. Hence it is preferable to have less number of columns for a given value of i .

There are many orthogonal functions which are subset of Rademacher function as shown below :

$$[B] = \begin{bmatrix} +1+1+1+1 \\ +1-1+1-1 \\ +1+1-1-1 \\ +1-1-1+1 \end{bmatrix} \quad [C] = \begin{bmatrix} -1+1+1+1 \\ +1-1+1+1 \\ +1+1-1+1 \\ +1+1+1-1 \end{bmatrix}$$

The matrices $[B]$ and $[C]$ are also orthogonal and are constructed using some columns of matrix $[A]$. The matrix $[B]$ consists of columns 1, 11, 13 and 7 of matrix $[A]$. Similarly matrix $[C]$ consists of columns 2, 3, 5 and 9 of matrix $[A]$. There are two more matrices that can be obtained from matrix $[A]$ which are orthogonal.

The matrix $[B]$ is the well known Hadamard matrix. The corresponding waveforms are shown in **Fig. 4. (a)**. In all these orthogonal matrices the columns of the matrix can be rearranged without altering the orthogonality condition. The rows of an orthogonal matrix can also be interchanged freely and the matrix is still orthogonal. **Fig. 4. (b)** shows another set of orthogonal functions derived from pseudo random sequence of length 7.

The Hadamard matrices are square matrices which are known to exist for i (the number of rows or columns) when the value of i is either a power of 2 or multiple of 4. The smallest matrix is of size 2×2 given below :

$$[H_2] = \begin{bmatrix} 1 & 1 \\ 1 & -1 \end{bmatrix} \quad (2)$$

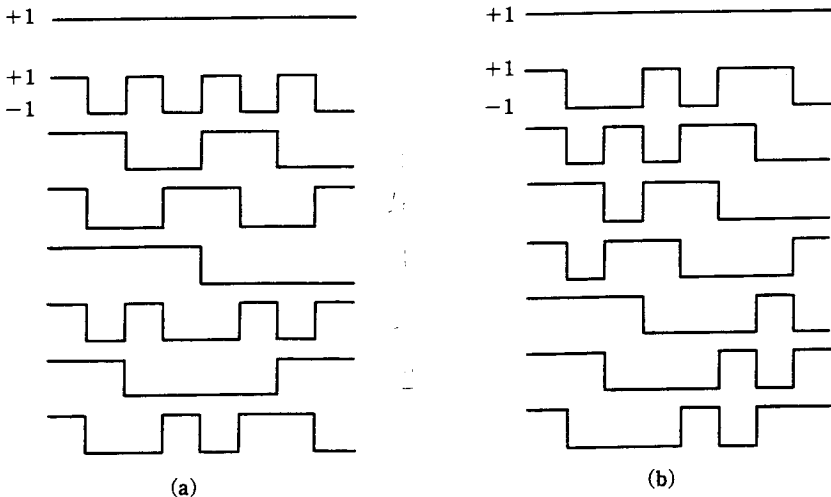

Fig. 4 Orthogonal waveforms corresponding to (a) Hadamard matrix and (b) PRBS of length 7.

The next higher size matrix of size 4×4 can easily be generated by using Kronecker product (\otimes) as shown below :

$$H_4 = H_2 \otimes H_2 = \begin{bmatrix} H_2 & H_2 \\ H_2 - H_2 & H_2 \end{bmatrix} = \begin{bmatrix} 1 & 1 & 1 & 1 \\ 1-1 & 1-1 & & \\ 1 & 1-1 & -1 & -1 \\ 1-1 & -1 & -1 & 1 \end{bmatrix} \quad (3)$$

These matrices consist of either +1 or -1 only and are simpler as compared to other orthogonal matrices like Haar or Slant matrices⁽¹⁰⁾. The orthogonal square matrices similar to Hadamard matrices are not known for other values of i (when i is not a power of two or multiple of four). A sub set of Hadamard matrix may be used in such cases. The Hadamard matrix of size larger than i is chosen. For example when i is 3, Hadamard matrix of size 4 is selected. The orthogonal matrix for $i=3$ is obtained by omitting any one of the rows of matrices $[A]$, $[B]$ or $[C]$. In matrix $[B]$, it is preferable to drop the first row so that dc free condition is obtained with minimum number of time intervals in a cycle. Similarly the orthogonal matrix for $L=5$ or 6 may be obtained by dropping any 3 or 2 rows of Hadamard matrix of size 8. Here again it is preferable to omit the row with all the elements +1 to keep the number of time intervals a minimum.

The rows or columns of the orthogonal matrices may be rearranged in any fashion. The rearrangement of rows of this matrix simply means reassigning the row waveforms. The rearrangement of columns corresponds to changing the frequency spectrum of a row waveform. The number of transitions in the addressing waveforms is also changed when the columns are rearranged.

2.2 Matrix addressing

The orthogonal functions are used for driving passive matrix LCDs as follows :

The matrices $[A]$ or $[B]$ or $[C]$ can be used for addressing a matrix display. The rows are applied with voltage waveforms corresponding to the rows of orthogonal matrix.

The desired state to which the pixels in a column are to driven is represented by the data matrix. Here the fully ON pixel may be represented by a value -1, fully OFF pixel is represented by +1.

The column voltage is determined to be proportional to the weighed sum of the orthogonal row waveforms. For example if d_i is the data to be displayed in i th row then the column voltage is given by

$$\text{column voltage} = d_1 \cdot F_1 + d_2 \cdot F_2 + d_3 \cdot F_3 + d_4 \cdot F_4 \quad (4)$$

From the equation (4) it is clear that the column voltage is obtained by multiplication of row waveforms with data and followed by summation. In the conventional technique only one of the row waveform has a non zero value and hence the column voltage is just

the pixel data. Also multiplication is not necessary when simple orthogonal function like Rademacher or Walsh functions having amplitudes of +1 or -1 only are used. The column voltage is obtained by adding the row waveforms with appropriate sign depending on the data to be displayed.

In a bilevel display (with pixels driven to either ON or OFF states) the number of voltage levels is $(L+1)$, wherein L is the number of rows selected simultaneously. The number of voltage levels in the column waveform increases with L . The concept of hybrid addressing was proposed⁽¹¹⁾ in 1983 to limit the number of time intervals and complexity of column driver to moderate levels. The N rows in the matrix are divided in to a number of subgroup each consisting of L rows. The scanning is done by selecting one subgroup at a time as compared to one row in the conventional addressing technique. The subgroup is selected using orthogonal function. For example the IHAT uses Rademacher function to select the subgroups. The same concept is used in SAT and the subgroups are selected with Hadamard matrices.

The Improved Hybrid Addressing Technique (IHAT)^{(8),(9)} uses Rademacher function (matrix $[A]$) to select the rows of a matrix display. Column voltage is obtained by just adding or subtracting the data to be displayed in a column depending on the row select pattern (a column of the orthogonal matrix).

The row waveforms and column waveforms are simultaneous applied to the LCD to display the desired information. **Figure 5** gives the comparison of row and column waveforms when a) Rectangular block pulses; b) Rademacher matrix and c) Hadamard matrix are used for addressing a matrix display with four rows ($N=4$). The number of time intervals in the waveforms depends on the orthogonal matrix used. The conventional addressing using the rectangular block pulses and the Hadamard matrix need four time intervals while the Rademacher functions need eight time intervals. This does not include the DC free operation and the number of time intervals is doubled when polarity reversal is included for DC free operation.

2.3 Sequency addressing technique (SAT)

The Sequency Addressing Technique⁽¹²⁾ is based on using Hadamard matrices which are orthogonal. This technique is same as that of IHAT except for the fact that a different orthogonal matrix is used. The use of Hadamard matrices (instead of Rademacher matrices as in IHAT) reduces the number of time intervals to complete a cycle.

The N rows in a matrix are divided into a number of subgroup each consisting of L rows. A suitable Hadamard matrix or its subset is chosen such that the number of orthogonal function or the number of rows in the matrix is equal to L . The elements of the orthogonal matrix are represented by Logic 0 for +1 and Logic 1 for -1. Thus a row

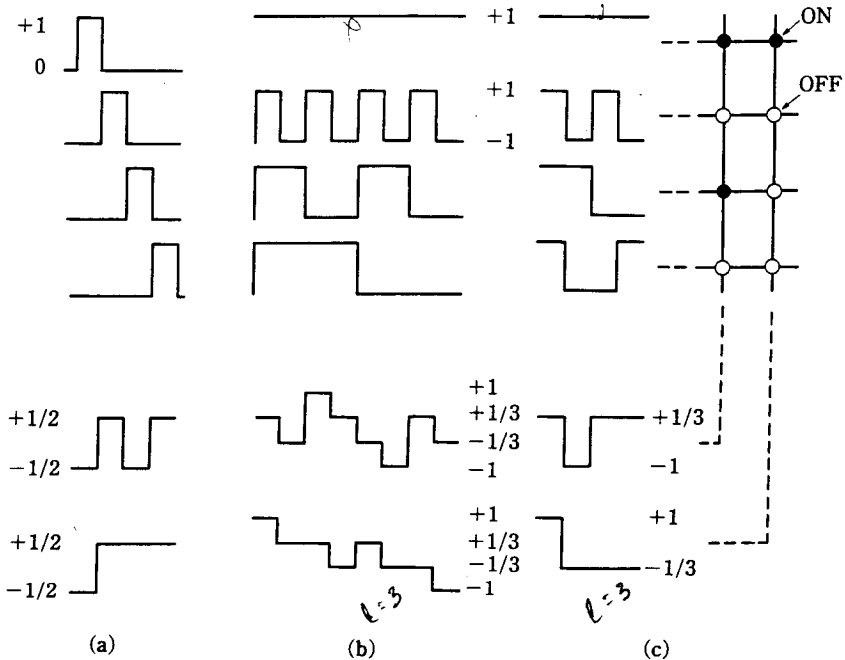

Fig. 5 The row and column waveforms when (a) Rectangular block functions, (b) Rademacher functions and (c) Hadamard matrices are used.

select voltage is $+V_r$ for Logic 0 and $-V_r$ for Logic 1. A column of this matrix is also called the row select pattern. The data to be displayed in a column is represented by Logic 0 for an OFF pixel and Logic 1 for an ON pixel. The data to be displayed in a column represented with such logic values is called the data pattern.

The column voltage is computed by comparing the row select pattern and data pattern bit by bit using EX-OR gates. The output of the gate is logic 1 when there is a mismatch between the corresponding bits of row select pattern and the data pattern. The number of mismatches (i) is counted. In the above operation the EX-OR gate is a one bit multiplier and correspond to multiplication of row waveform with data as shown in **Table 1.1** and **Table 1.2**.

The counting of mismatches corresponds to summation of the products in equation (4). The number of mismatches is sent to the column driver(s), where the appropriate voltages are applied to the LCD matrix using analog multiplexers. The column voltage is $V_c \cdot (L - 2 \cdot i) / L$; wherein V_c is the maximum amplitude of the column voltage. These voltages corresponding to different mismatches, are applied to the input of the analog

Table 1.1 Truth Table of EX-OR Gate.

Input		Output
A	B	C
0	0	0
0	1	1
1	0	1
1	1	0

Table 1.2 Truth Table of 1-bit Multiplier.

Input		Output
X	Y	Z
+ 1	+ 1	+ 1
+ 1	- 1	- 1
- 1	+ 1	- 1
- 1	- 1	+ 1

Table 2 Number of Time Intervals in a Cycle for SAT.

L (the number of rows in a subgroup)		2	3	4	5	6	7	8	9
Number of time intervals for :	addressing	2 S	4 S	4 S	8 S	8 S	8 S	8 S	16 S
	a cycle	4 S	4 S	8 S	8 S	8 S	8 S	16 S	16 S

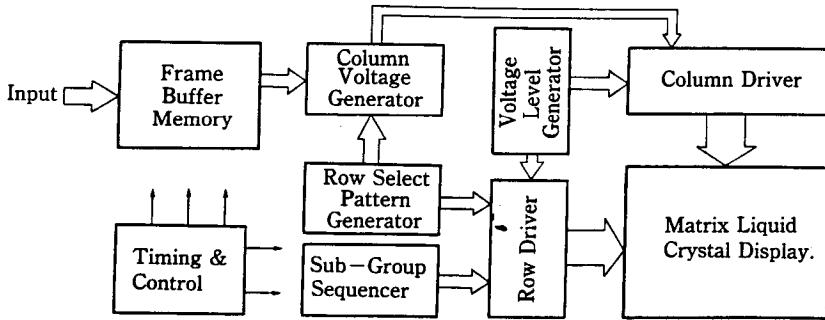

Fig. 6 Block diagram of display addressed with SAT.

multiplexers in the column drivers. Another row select pattern (column of the orthogonal matrix) is chosen and the corresponding column voltages are generated as described above. The number of time intervals to complete a cycle depends on the orthogonal function and the dc free condition. **Table 2** gives the number of time intervals in a cycle (including dc free operation) for SAT. The *S* in **Table 2** is the number of subgroups in the display and the number of time intervals is the minimum. The block diagram of the display addressed with SAT is given in **Fig. 6**.

The condition for maximum selection ratio is $V_r = N^{1/2} \cdot V_c / L$; where in V_r and V_c are the maximum amplitudes of the row and column voltages respectively.

This is same as that of IHAT. Similarly the expression for the rms voltage across the pixels and the supply voltage of the drive electronics is same as that of IHAT given in reference 8. This is natural since, the Hadamard matrix for a given value of *L* is a sub set of Rademacher matrix for the same value of *L*. This makes the number of time interval to

complete a cycle small as compared to IHAT. The number of time intervals to complete a cycle depends on the orthogonal function used.

Suppressing the frame response in fast responding LCDs using these novel addressing techniques is discussed next.

3 Suppressing Frame Response

The frame response can be suppressed in fast responding LCDs by taking following measures :

3.1 Scanning method

The scanning of the matrix display can be done in a number of ways. A sub group may be selected with all the row select patterns before another subgroup is selected. The corresponding row waveforms contain all the row select pulses adjacent to each other as shown in Fig. 7. a. However this method is not suitable for fast responding LCDs, since the transmission of OFF pixels increases due to a large row select time.

Alternatively a new sub group may be selected after selecting a sub group with one row select pattern as shown in Fig. 7. b. This scanning method is a better approach to suppress the frame response since the row select pulses are distributed and hence the absolute time between two row select pulses is small. This is equivalent to increasing the frame frequency in the conventional addressing technique. The pulse width is larger than the conventional technique since L rows are selected simultaneously.

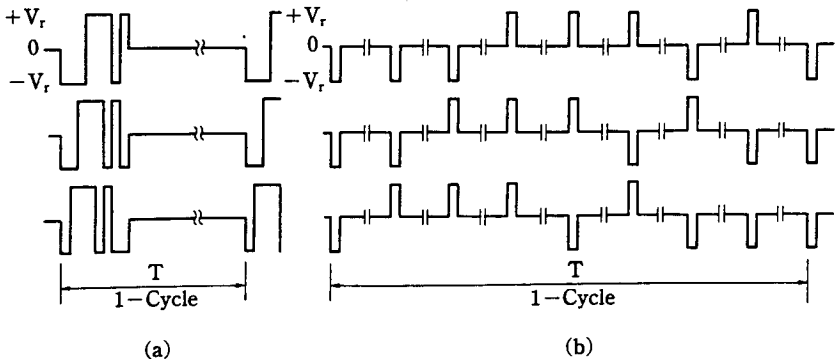

Fig. 7 Row select pulses are (a) adjacent to each other and (b) distributed in a cycle. (IHAT $L=3$)

3-2 Choice of L

The number of lines L in a subgroup, which are selected simultaneously is an important parameter. The amplitude of the row select voltage decreases with increase of L and the amplitude of the column voltage increases with L . The number of voltage levels again increases with L . Thus the hardware complexity and the cost increases with L . Hence the minimum value of L which is just adequate to suppress the frame response is the best solution. **Table 3** gives a comparison of contrast ratio and efficiency for various L values. The efficiency here is the ratio of contrast ratio obtained for a given L to the contrast ratio obtained with square waveforms having the same selection ratio.

3-3 Row select time

The row select time should be such that the time interval to complete a cycle is small as compared to the response time of the LCD. This is important since this is the basic assumption in all the addressing techniques for rms responding devices. There is an optimum row select time for which the contrast ratio is maximum. The contrast ratio as function of row select time is shown in **Fig. 8** for LCDs with average response time of 50 ms and 250 ms respectively. In the case of LCD with 250 ms response time, contrast ratio is about the same for the row select time in the range 10 to 100 μ s. This indicates that the LCD with 250 ms response time exhibits rms behavior in this region when SAT is used for addressing this display with $N=490$ and $L=7$.

The brightness uniformity of pixels is important in addition to high contrast ratio in the display. This aspect is discussed next.

Table 3 Comparison of Contrast Ratio of SAT for Various Values of L .

L	Contrast Ratio			Efficiency (%)		
	20 μ s	40 μ s	60 μ s	20 μ s	40 μ s	60 μ s
1	25	7	4	38	10	6
3	49	29	17	75	43	28
7	59	50	40	91	75	66
15	58	48	37	89	72	61
31	52	38	26	80	57	44
63	57	48	37	88	72	61
127	55	46	36	85	69	59
240	61	52	44	94	78	72

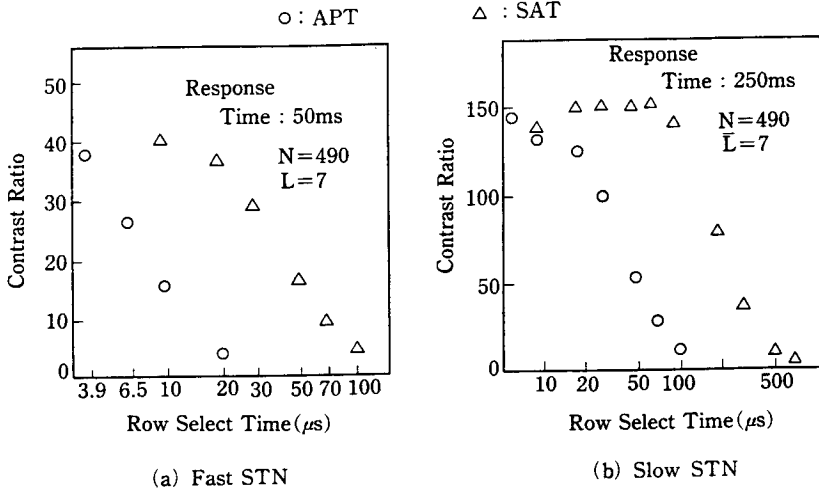

Fig. 8 Contrast ratio vs row select time for LCD with average response time of (a) 50 ms and (b) 250 ms. (triangles for SAT and circles for conventional technique).

4 Brightness Uniformity of the Display

Brightness uniformity is an important parameter to improve the quality of the display. Any two pixels in a display which are driven to the same state should appear the same. However this is not true in most displays and this will be referred to as the brightness non-uniformity of pixels. The brightness uniformity of pixel is not only important for the good appearance of the display but also influences the number of gray shades that can be displayed. The brightness nonuniformity in the display is due to the following reasons :

4.1 Frequency dependence of threshold voltage

While the rms voltage across pixels driven to the same state in a display may be the same, the frequency component across the pixels will be different depending upon the addressing waveforms, the polarity reversal sequence and the information displayed in that column. The brightness uniformity can be improved by selecting liquid crystal mixtures with flat threshold characteristics over a wide frequency range and selecting the addressing waveforms and or polarity reversal sequences to suit the display characteristics.

4.2 Distortion in the addressing waveforms

The distortion in the addressing waveforms is due to the resistances and capacitances in the display panel. The addressing waveforms applied at one side of the panel is distorted due to the resistance of the transparent electrodes and the capacitance of the pixels. This distortion can be decreased by reducing the resistance of the electrodes. The waveforms are also distorted due to ON resistance of analog switches in the LCD drivers and finite impedances in the Voltage Level Generator. While the ON resistance of the analog switches in the row and column drivers and the resistance of the interconnection between the display and drivers can be reduced to certain extent it is not possible to reduce them to zero. Thus there will be some brightness non-uniformity due to the finite resistances. Alternatively if the number of transitions in all the addressing waveforms is made equal then brightness of all the pixels are changed equally. In this approach it is possible to allow for larger ON resistance for the analog switches, which can lead to higher integration and reduction in cost of LCD drivers. The number of transitions in the waveform may made equal by choosing proper polarity sequence in the conventional addressing waveforms. Similarly the brightness uniformity can be improved by choosing the proper row select sequences such that the number of transitions in the waveform is independent of the data displayed.

4.3 Sequence of row select patterns

There are a number of possible ways in which the scanning of the matrix may be carried out. For example; all the sub-groups in the matrix may be selected with one row select pattern once before changing to another row select pattern as shown in **Table 4. (a)**. Alternatively, the row select pattern may be changed when ever a new sub-group is selected as shown in **Table 4. (b)**. There is a whole range of other possibilities like changing the row select pattern after selecting say 2, 4, ... etc. subgroups as shown in **Tables 4. (c)** and **4. (d)**. The sequence of the row select pattern also affects the brightness uniformity of pixels. The choice of these sequences depends on the characteristics of the display used. The sequence shown in **Table 4. b** is generally suitable for fast responding LCDs.

Choice of addressing technique also plays a role in the brightness uniformity. **Figure 9** shows 7 different display patterns which were used to evaluate the brightness uniformity of the conventional addressing technique and SAT. The brightness uniformity of the pixels for SAT can be compared with that of the conventional technique in **Fig. 10**. From this figure, it is clear that the brightness uniformity is good when SAT is used for driving the display.

Good brightness uniformity is a prerequisite for displaying gray shades in a display.

Table 4 Sequencies of Row Select Patterns. The Row Select Patterns are Changed after Selecting (a) All the subgroups, (b) Each subgroup, (c) Two subgroups and (d) four subgroups.

(a)	Sub-group No.	1	2	3	...	(N/L)	1	2	3	...	(N/L)	1	2	...					
	Row Select Pattern	1	1	1	1..	1	2	2	2	2..	2	3	3	...					
(b)	Sub-group No.	1	2	3	4	5	..	(N/L)	1	2	3	4	5	..	(N/L)	1	..		
	Row Select Pattern No.	1	2	3	4	5	..		2	3	4	5	6	..		3	..		
(c)	Sub-group No.	1	2	3	4	5	6	..	(N/L)	1	2	3	4	5	6	..	(N/L)	1	..
	Row Select Pattern No.	1	1	2	2	3	3	2	2	3	3	4	4	..		3	..
(d)	Sub-group No.	1	2	3	4	5	6	..	(N/L)	1	2	3	4	5	6	..	(N/L)	1	...
	Row Select Pattern No.	1	1	1	1	2	2	2	2	2	2	3	3	..		3	...

Table 5 Column Voltages for Various Values of k.

Normalized gray shade value.	Column voltage in first time slot	Column voltage in second time slot
-1.0	-1.0	-1.0
-0.8	-0.2	-1.4
-0.6	+0.2	-1.4
-0.4	+0.516	-1.316
-0.2	+0.779	-1.179
0.0	+1.0	-1.0
+0.2	+1.179	-0.779
+0.4	+1.316	-0.516
+0.6	+1.4	-0.2
+0.8	+1.4	+0.2
+1.0	+1.0	+1.0

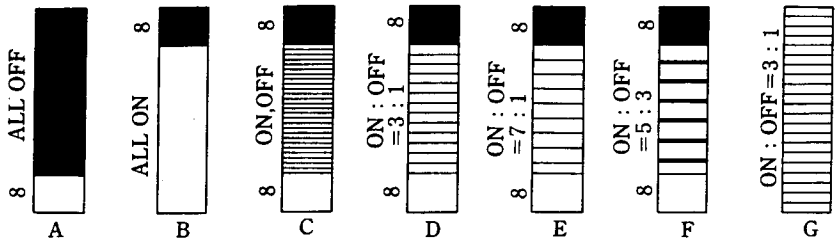

Display Pattern

Fig. 9 Various display patterns used for evaluating the brightness uniformity of pixels.

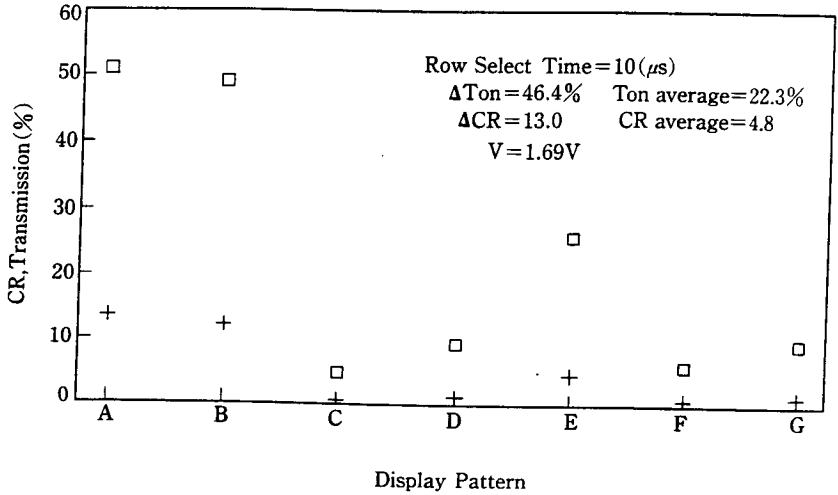

(a) Brightness Uniformity - APT.

□ : Ton + : CR

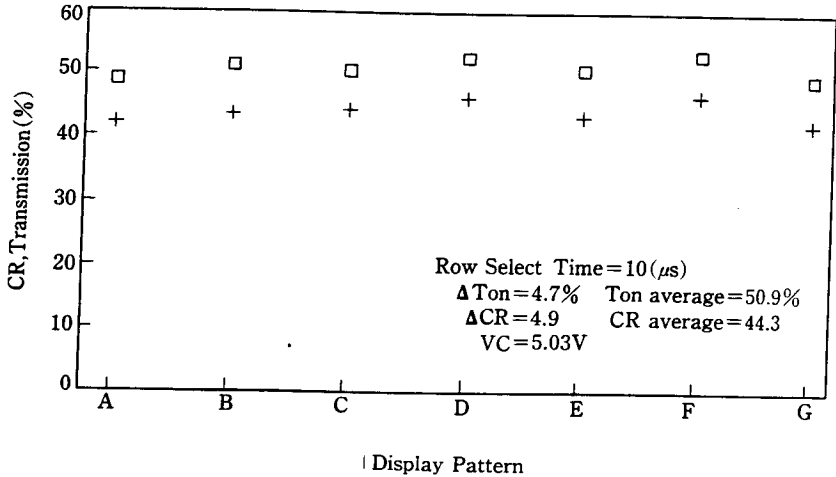

(b) Brightness Uniformity - SAT. L=8

□ : Ton + : CR

Fig. 10 Contrast ratio and Transmission of various display patterns for (a) APT and (b) SAT. $N=480$

Methods for generating gray shades in LCDs will be discussed next.

5 Displaying Gray Shades

The discussion so far was confined to addressing a bilevel display where the pixels are either ON or OFF. While these displays cater to some applications the capability to display intermediate gray shades is desirable in most of the applications.

A pixel can be made to display intermediate gray shades by applying appropriate voltage in the range of threshold voltage to saturation voltage of the LCD used. While this appears simple, care must be taken to ensure that changing the voltage for a given pixel does not alter the state of other pixels in a matrix display. The conventional approach for gray shades are Pulse width modulation and Frame modulation. The time duration for which a pixel is ON is varied in both these techniques to achieve the required gray shade.

5.1 Pulse width modulation

Figure 11. a shows the Pulse width modulation. The row select time is divided into $(2^n - 1)$ time intervals to display 2^n gray shades. The width of the pulse becomes smaller and smaller as the number of gray shades are increased. This results in brightness non uniformity of pixels. For example a row select time is divided into 7 sub-intervals to display 8 gray shades.

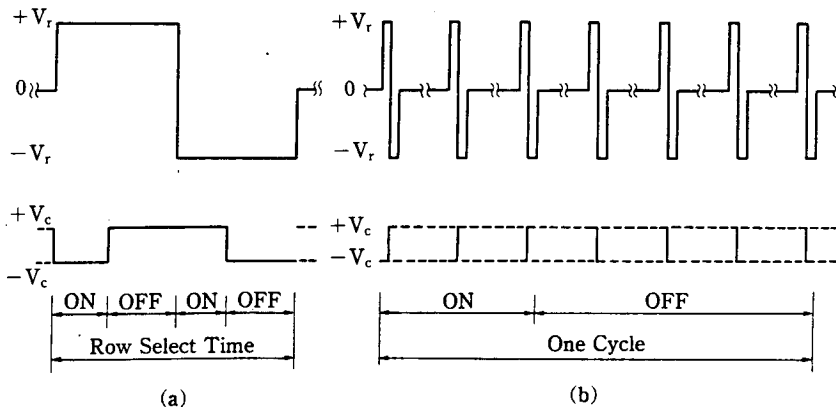

Fig. 11 (a) Pulse width modulation and (b) Frame modulation for generating gray shades in LCDs.

5-2 Frame modulation

In the case of frame modulation shown in **Fig. 11**, b the pixels turned ON and OFF in different frames to obtain the necessary gray shades. Here 8 gray shades are obtained using 7 frames. In general, $(2^n - 1)$ frames are used to display 2^n gray shades. The display exhibits flicker as the number of gray shades is increased.

5-3 Cycle modulation

In the conventional Alt and Pleshko Technique (APT) one row is selected only once in each frame. In other words the addressing is complete when each and every row is selected once. However this does not apply to SAT, wherein the same row is selected several times to complete the addressing. For example when $L=3$, each and every row is selected 4 times before the addressing is complete. The total number of time intervals to complete a cycle is $4N/3$ here as compared to N in the APT. This depends on the orthogonal functions as discussed in section 2-1 in the above text. The principle of frame modulation when applied to SAT is called the cycle modulation to show the difference in the number of time intervals and the scanning.

In the above discussion the dc free condition is not included. In the conventional addressing technique $2N$ time intervals are necessary for dc free operation.

In general $(n+1)$ gray shades can be displayed when the row select time is divided in to n time intervals in pulse width modulation. Similarly $(n+1)$ gray shades are possible with n frames (or in cycle) in frame modulation. Both these techniques thus have practical limit of about eight gray shades. An alternate approach to display gray shade is Amplitude modulation⁽¹³⁾ which will be discussed below.

6 Amplitude Modulation

In the conventional addressing technique ; the amplitude of the column voltage is same (V_c) while the sign is changed depending on the data. This is necessary to make the rms voltage across the pixels to be independent of the data displayed in a column. The principle of Amplitude modulation as applied to the conventional Alt and Pleshko Technique is outlined below.

6-1 AM-APT

The amplitude of the column voltage may be changed to change the rms voltage across a pixel, however this results in a change of rms voltage across all the pixels in that

column as shown in the following equation :

Let $k \cdot V_c$ be the column voltage applied to display gray shade in a pixel. As can be seen from equation (5), the rms voltage across the pixel will depend on the value k .

$$V_{\text{pixel}} = (((V_r - k \cdot V_c)^2 + (N-1)V_c^2)/N)^{1/2} \quad (5)$$

The rms voltage across another pixel in the same column is given by,

$$V_{\text{column}} = (((V_r - V_c)^2 + (k \cdot V_c)^2 + (N-2)V_c^2)/N)^{1/2} \quad (6)$$

From the above expression it is clear that the rms voltage across all the pixels in the same column is also changed. The choice of column voltage should be such that the rms voltage is changed only for the desired pixel and does not affect the other pixels in the unselected rows. This is possible when the row select time is split in to two time intervals. The column voltage for these two time intervals are different as given below :

$$V_{c1} = (k + (1 - k^2)^{1/2}) V_c \quad (7)$$

$$V_{c2} = (k - (1 - k^2)^{1/2}) V_c \quad (8)$$

When these two column voltages are used the rms voltage of the pixel in the selected row is changed without altering the rms voltage across the other pixels. The second term in the equations (7) and (8) viz. ; $(1 - k^2)^{1/2}$ can be thought of as a correction term which is added in one time slot and subtracted in the next time slot. The rms voltage across a pixel is given by :

$$V_{\text{pixel}} = (((V_r - V_{c1})^2 + (V_r - V_{c2})^2 + 2(N-1)V_c^2)/2N)^{1/2} \quad (9)$$

This reduces to the following expression,

$$V_{\text{pixel}} = ((V_r^2 - 2 \cdot k \cdot V_r \cdot V_c + N \cdot V_c^2)/N)^{1/2} \quad (10)$$

From the above expression it is clear that rms voltage across a pixel can be varied to achieve gray shades. The value of k ranges from -1 to $+1$. The value -1 corresponds to the fully ON state while $k = +1$ corresponds to fully OFF. Any intermediate gray shade can be generated by assigning appropriate value for k within this range. The column voltages V_{c1} and V_{c2} for various values of k , corresponding to different gray levels are given in **Table 5**. The column voltage thus has many voltage levels and an analog type column driver used in the active matrix display is necessary as column drivers.

The main advantage of this technique is that a large number of gray shades can be displayed without any flicker, since only two frames are necessary to complete a cycle.

The principle of amplitude modulation is also extended to SAT. The column waveform has many voltage levels and hence the analog type column drivers used for active matrix displays are necessary. The row waveforms however have only three voltage levels.

6.2 AM-SAT

The Amplitude Modulation can be used with any addressing technique. The Amplitude Modulated Sequency Addressing Technique (AM-SAT) is specially suitable for fast responding LCDs, since a large number of gray shades can be displayed without flicker. The column voltage is computed as follows :

The correction term which is necessary to make the rms voltage independent of the information to be displayed in the column is given below :

$$k_0 = (L - (k_1^2 + k_2^2 + \dots + k_L^2))^{1/2} \quad (11)$$

wherein k_1, k_2, \dots, k_L are the gray shade values normalized between -1 (for ON) to $+1$ (for OFF) and L is the number of rows selected simultaneously.

The correction term k_0 is an additional data to compute the column voltage. An orthogonal matrix $[o_{Lj}]$ with $(L+1)$ rows is used here.

$$\text{column voltage}_j = \sum_{i=0}^L o_{Lj} \cdot k_i \quad (12)$$

From the above expressions it is clear that the correction term has to be computed before the column voltages are computed. The block diagram of the column voltage generator for AM-SAT is shown in Fig. 12. The row waveforms of AM-SAT are same as that of the SAT. The condition for the maximum selection ratio is also the same as SAT. Typical addressing waveform of AM-SAT is shown in Fig. 13.

6.3 Response times of AM-SAT

In addition to high contrast ratio and brightness uniformity of pixels, the time taken to switch from one gray shade to another should be as short as possible. Measurement of response times, when a pixel is switched between eight gray shades using AM-SAT is shown in Table 6. The values $1/7, 2/7, 3/7, 4/7, 5/7, 6/7$ represent the gray shades between OFF (0) and ON (1). The upper triangle in Table 6 gives the rise times, while

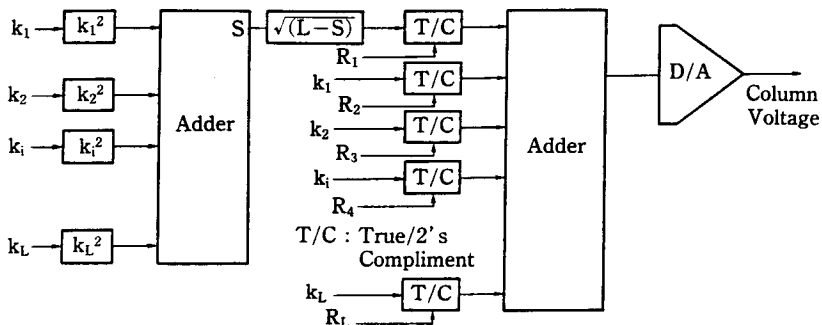

Fig. 12 Column voltage generator for AM-SAT.

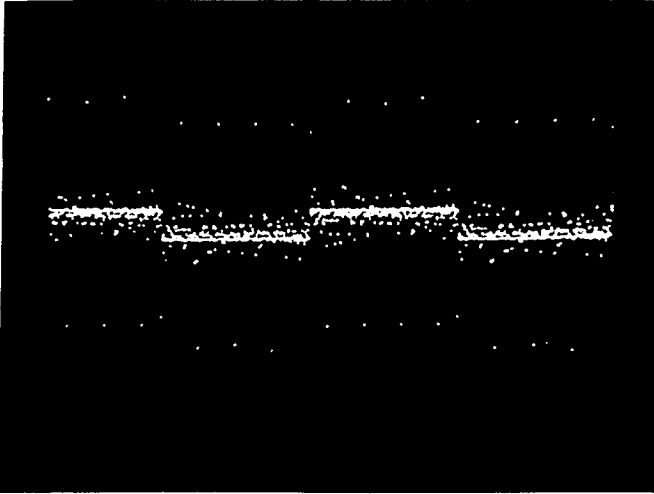

Fig. 13 Typical addressing waveform of AM-SAT.

Table 6 Response Times (in ms) when AM-SAT is used for Addressing.

	0	1/7	2/7	3/7	4/7	5/7	6/7	1
0	—	97	109	111	115	108	95	66
1/7	57	—	99	103	105	99	85	61
2/7	54	88	—	85	97	94	80	56
3/7	51	84	83	—	100	94	82	58
4/7	52	84	92	104	—	101	79	53
5/7	56	88	98	106	113	—	57	48
6/7	55	84	95	102	102	75	—	51
1	60	86	97	104	101	90	82	—

the lower triangle gives the decay time when a pixel is switched between gray shades. Time taken to switch between one gray shade to another falls in the range of 50 ms to 115 ms in a LCD with average response time of 50 ms. This is approximately a factor of two as compared to a factor of three or four in the case of Active matrix LCDs.

7 Conclusions

The novel addressing techniques suitable for driving fast responding LCDs were

discussed. Considerable improvement in the performance of the passive matrix display is possible with the development of faster STN displays and the new addressing techniques. While these improvements are possible with the new addressing techniques, development of new liquid crystal materials and display cell structures is necessary to bring out the full potential of Passive matrix displays.

—References—

- (1) Alt, P.M. and Pleshko, P., *IEEE Trans. ED*, Vol.ED-21, pp.146-155, 1974.
- (2) Nehring, J. and Kmetz, A.R., *IEEE Trans. ED*, Vol.ED-26, pp.795-802, 1979.
- (3) Clark, K.G. Shanks, I.A. and Patterson N.J., *SID Digest*, pp.110-111, 1979.
- (4) Kaneko, Y., et al., *EURODISPLAY '90*, pp.100-103, 1990.
- (5) Kondo, S., et al., *SID 91 Digest*, pp.747-750, 1991.
- (6) Okada, K., et al., *SID 91 Digest*, pp.430-433, 1991.
- (7) Madhusudana, N.V. and Ruckmongathan, T.N., *Liquid Crystals, Proc. of Int. Conf.*, Ed. Chandrasekhar, S., Hyden, pp.499-503, 1980.
- (8) Ruckmongathan, T.N., *Proc. IDRC*, pp.80-85, 1988.
- (9) Ihara, S., et al., *SID 92 Digest*, pp.232-235, 1992.
- (10) Ahmed, N. and Rao, K.R., *Orthogonal Transforms for Digital Signal Processing*, Springer-Verlag, 1975.
- (11) Ruckmongathan, T.N. and Madhusudana, N.V., *Proc. of the SID*, Vol.24/3, pp.259-262, 1983.
- (12) Ruckmongathan, T.N., et al., *Japan Display '92*, pp.65-68, 1992.
- (13) Ruckmongathan, T.N., *Japan Display '92*, pp.77-80, 1992.

